

AD573—SPECIFICATIONS (@ $T_A = +25^\circ\text{C}$, $V_+ = +5\text{ V}$, $V_- = -12\text{ V}$ or -15 V , all voltages measured with respect to digital common, unless otherwise noted.)

Model	AD573J			AD573K			AD573S			Units
	Min	Typ	Max	Min	Typ	Max	Min	Typ	Max	
RESOLUTION	10			10			10			Bits
RELATIVE ACCURACY ¹ $T_A = T_{\text{MIN}}$ to T_{MAX}	± 1			$\pm 1/2$			± 1			LSB LSB
FULL-SCALE CALIBRATION ²	± 2			± 2			± 2			LSB
UNIPOLAR OFFSET	± 1			$\pm 1/2$			± 1			LSB
BIPOLAR OFFSET	± 1			$\pm 1/2$			± 1			LSB
DIFFERENTIAL NONLINEARITY ³ $T_A = T_{\text{MIN}}$ to T_{MAX}	10			10			10			Bits Bits
TEMPERATURE RANGE	0		+70	0		+70	-55		+125	$^\circ\text{C}$
TEMPERATURE COEFFICIENTS ⁴										
Unipolar Offset			± 2			± 1			± 2	LSB
Bipolar Offset			± 2			± 1			± 2	LSB
Full-Scale Calibration ²			± 4			± 2			± 5	LSB
POWER SUPPLY REJECTION										
Positive Supply $+4.5\text{ V} \leq V_+ \leq +5.5\text{ V}$			± 2			± 1			± 2	LSB
Negative Supply $-15.75\text{ V} \leq V_- \leq -14.25\text{ V}$			± 2			± 1			± 2	LSB
$-12.6\text{ V} \leq V_- \leq -11.4\text{ V}$			± 2			± 1			± 2	LSB
ANALOG INPUT IMPEDANCE	3.0	5.0	7.0	3.0	5.0	7.0	3.0	5.0	7.0	k Ω
ANALOG INPUT RANGES										
Unipolar	0		+10	0		+10	0		+10	V
Bipolar	-5		+5	-5		+5	-5		+5	V
OUTPUT CODING										
Unipolar	Positive True Binary			Positive True Binary			Positive True Binary			
Bipolar	Positive True Offset Binary			Positive True Offset Binary			Positive True Offset Binary			
LOGIC OUTPUT										
Output Sink Current ($V_{\text{OUT}} = 0.4\text{ V max}$, T_{MIN} to T_{MAX})	3.2			3.2			3.2			mA
Output Source Current ⁵ ($V_{\text{OUT}} = 2.4\text{ V min}$, T_{MIN} to T_{MAX})	0.5			0.5			0.5			mA
Output Leakage			± 40			± 40			± 40	μA
LOGIC INPUTS										
Input Current			± 100			± 100			± 100	μA
Logic "1"	2.0			2.0			2.0			V
Logic "0"			0.8			0.8			0.8	V
CONVERSION TIME $T_A = T_{\text{MIN}}$ to T_{MAX}	10	20	30	10	20	30	10	20	30	μs
POWER SUPPLY										
V_+	+4.5	5.0	+7.0	+4.5	+5.0	+7.0	+4.5	+5.0	+7.0	V
V_-	-11.4	-15	-16.5	+11.4	-15	-16.5	-11.4	-15	-16.5	V
OPERATING CURRENT										
V_+		15	20		15	20		15	20	mA
V_-		9	15		9	15		9	15	mA

NOTES

¹Relative accuracy is defined as the deviation of the code transition points from the ideal transfer point on a straight line from the zero to the full scale of the device.

²Full-scale calibration is guaranteed trimmable to zero with an external 50 Ω potentiometer in place of the 15 Ω fixed resistor. Full scale is defined as 10 volts minus 1 LSB, or 9.990 volts.

³Defined as the resolution for which no missing codes will occur.

⁴Change from $+25^\circ\text{C}$ value from $+25^\circ\text{C}$ to T_{MIN} or T_{MAX} .

⁵The data output lines have active pull-ups to source 0.5 mA. The $\overline{\text{DATA READY}}$ line is open collector with a nominal 6 k Ω internal pull-up resistor.

Specifications subject to change without notice.

Specifications shown in **boldface** are tested on all production units at final electrical test. Results from those tests are used to calculate outgoing quality levels. All min and max specifications are guaranteed, although only those shown in boldface are tested on all production units.

ABSOLUTE MAXIMUM RATINGS

V+ to Digital Common	0 V to +7 V
V- to Digital Common	0 V to -16.5 V
Analog Common to Digital Common	±1 V
Analog Input to Analog Common	±15 V
Control Inputs	0 V to V+
Digital Outputs (High Impedance State)	0 V to V+
Power Dissipation	800 mW

ORDERING GUIDE¹

Model	Package Option ²	Temperature Range	Relative Accuracy
AD573JN	20-Pin Plastic DIP (N-20)	0°C to +70°C	±1 LSB max
AD573KN	20-Pin Plastic DIP (N-20)	0°C to +70°C	±1/2 LSB max
AD573JP	20-Pin Leaded Chip Carrier (P-20A)	0°C to +70°C	±1 LSB max
AD573KP	20-Pin Leaded Chip Carrier (P-20A)	0°C to +70°C	±1/2 LSB max
AD573JD	20-Pin Ceramic DIP (D-20)	0°C to +70°C	±1 LSB max
AD573KD	20-Pin Ceramic DIP (D-20)	0°C to +70°C	±1/2 LSB max
AD573 SD	20-Pin Ceramic DIP (D-20)	-55°C to +125°C	±1 LSB max

NOTES

¹For details on grade and package offerings screened in accordance with MIL-STD-883, refer to Analog Devices Military Products Databook.

²D = Ceramic DIP; N = Plastic DIP; P = Plastic Leaded Chip Carrier.

FUNCTIONAL DESCRIPTION

A block diagram of the AD573 is shown in Figure 1. The positive CONVERT pulse must be at least 500 ns wide. \overline{DR} goes high within 1.5 μ s after the leading edge of the convert pulse indicating that the internal logic has been reset. The negative edge of the CONVERT pulse initiates the conversion. The internal 10-bit current output DAC is sequenced by the integrated injection logic (I^2L) successive approximation register (SAR) from its most significant bit to least significant bit to provide an output current which accurately balances the input signal current through the 5 k Ω resistor. The comparator determines whether the addition of each successively weighted bit current causes the DAC current sum to be greater or less than the input current; if the sum is more, the bit is turned off. After testing all bits, the SAR contains a 10-bit binary code which accurately represents the input signal to within 1/2 LSB (0.05% of full scale).

The SAR drives \overline{DR} low to indicate that the conversion is complete and that the data is available to the output buffers. \overline{HBE} and \overline{LBE} can then be activated to enable the upper 8-bit and lower 2-bit buffers as desired. \overline{HBE} and \overline{LBE} should be brought high prior to the next conversion to place the output buffers in the high impedance state.

The temperature compensated buried Zener reference provides the primary voltage reference to the DAC and ensures excellent stability with both time and temperature. The bipolar offset input controls a switch which allows the positive bipolar offset current (exactly equal to the value of the MSB less 1/2 LSB) to be injected into the summing (+) node of the comparator to offset the DAC output. Thus the nominal 0 V to +10 V unipolar input range becomes a -5 V to +5 V range. The 5 k Ω thin-film input resistor is trimmed so that with a full-scale input signal, an input current will be generated which exactly matches the DAC output with all bits on.

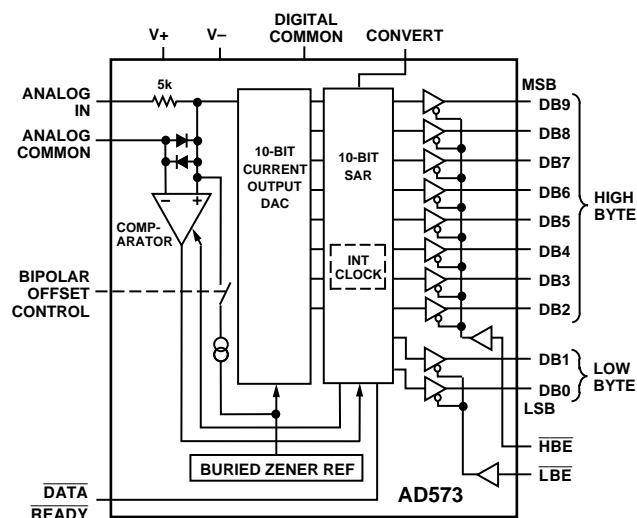

Figure 1. Functional Block Diagram

UNIPOLAR CONNECTION

The AD573 contains all the active components required to perform a complete A/D conversion. Thus, for many applications, all that is necessary is connection of the power supplies (+5 V and -12 V to -15 V), the analog input and the convert pulse. However, there are some features and special connections which should be considered for achieving optimum performance. The functional pinout is shown in Figure 2.

The standard unipolar 0 V to +10 V range is obtained by shorting the bipolar offset control pin (Pin 16) to digital common (Pin 17).

AD573

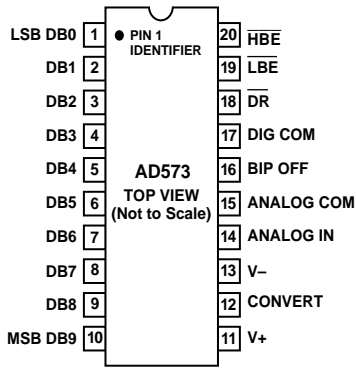

Figure 2. AD573 Pin Connections

Full-Scale Calibration

The 5 k Ω thin-film input resistor is laser trimmed to produce a current which matches the full-scale current of the internal DAC—plus about 0.3%—when an analog input voltage of 9.990 volts (10 volts – 1 LSB) is applied at the input. The input resistor is trimmed in this way so that if a fine trimming potentiometer is inserted in series with the input signal, the input current at the full-scale input voltage can be trimmed down to match the DAC full-scale current as precisely as desired. However, for many applications the nominal 9.99 volt full scale can be achieved to sufficient accuracy by simply inserting a 15 Ω resistor in series with the analog input to Pin 14. Typical full-scale calibration error will then be within ± 2 LSB or $\pm 0.2\%$. If more precise calibration is desired, a 50 Ω trimmer should be used instead. Set the analog input at 9.990 volts, and set the trimmer so that the output code is just at the transition between 11111111 10 and 11111111 11. Each LSB will then have a weight of 9.766 mV. If a nominal full scale of 10.24 volts is desired (which makes the LSB have a weight of exactly 10.00 mV), a 100 Ω resistor and a 100 Ω trimmer (or a 200 Ω trimmer with good resolution) should be used. Of course, larger full-scale ranges can be arranged by using a larger input resistor, but linearity and full-scale temperature coefficient may be compromised if the external resistor becomes a sizeable percentage of 5 k Ω . Figure 3 illustrates the connections required for full-scale calibration.

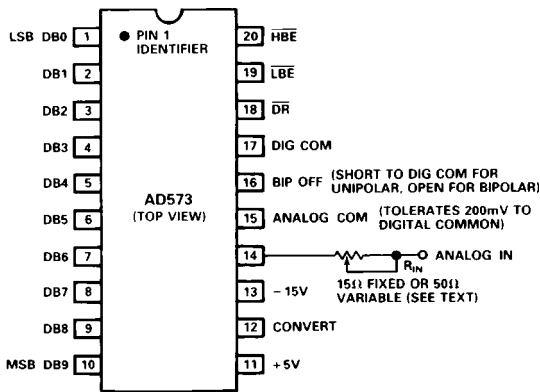

Figure 3. Standard AD573 Connections

Unipolar Offset Calibration

Since the Unipolar Offset is less than ± 1 LSB for all versions of the AD573, most applications will not require trimming. Figure 4 illustrates two trimming methods which can be used if greater accuracy is necessary.

Figure 4a shows how the converter zero may be offset by up to ± 3 bits to correct the device initial offset and/or input signal offsets. As shown, the circuit gives approximately symmetrical adjustment in unipolar mode.

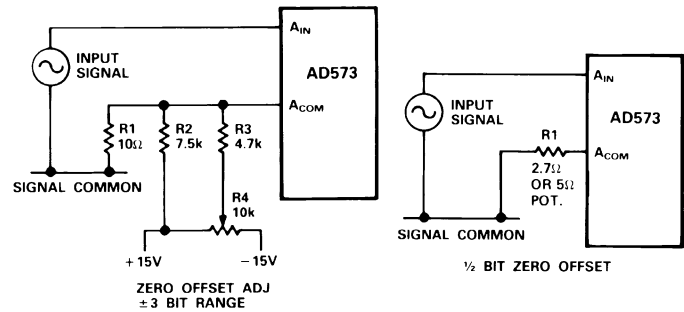

Figure 4a.

Figure 4b.

Figure 4. Offset Trims

Figure 5 shows the nominal transfer curve near zero for an AD573 in unipolar mode. The code transitions are at the edges of the nominal bit weights. In some applications it will be preferable to offset the code transitions so that they fall between the nominal bit weights, as shown in the offset characteristics.

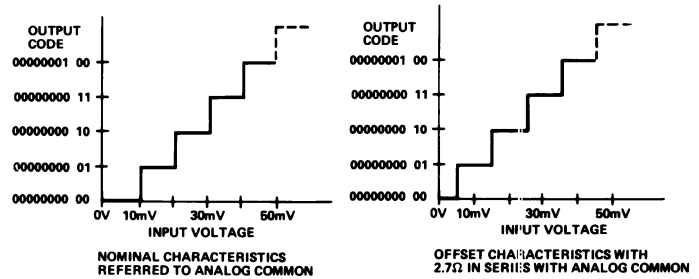

Figure 5. AD573 Transfer Curve—Unipolar Operation (Approximate Bit Weights Shown for Illustration, Nominal Bit Weights ~ 9.766 mV)

This offset can easily be accomplished as shown in Figure 4b. At balance (after a conversion) approximately 2 mA flows into the Analog Common terminal. A 2.7 Ω resistor in series with this terminal will result in approximately the desired 1/2 bit offset of the transfer characteristics. The nominal 2 mA Analog Common current is not closely controlled in manufacture. If high accuracy is required, a 5 Ω potentiometer (connected as a rheostat) can be used as R1. Of course, if the zero transition point is changed, the full-scale transition point will also move. Thus, if an offset of 1/2 LSB is introduced, full-scale trimming as described on the previous page should be done with an analog input of 9.985 volts.

NOTE: During a conversion, transient currents from the Analog Common terminal will disturb the offset voltage. Capacitive decoupling should not be used around the offset network. These transients will settle appropriately during a conversion. Capacitive decoupling will “pump up” and fail to settle resulting in conversion errors. Power supply decoupling, which returns to analog signal common, should go to the signal input side of the resistive offset network.

BIPOLAR CONNECTION

To obtain the bipolar -5 V to $+5\text{ V}$ range with an offset binary output code, the bipolar offset control pin is left open.

A -5.000 volt signal will give a 10-bit code of 00000000 00; an input of 0.000 volts results in an output code of 10000000 00 and $+4.99$ volts at the input yields the 11111111 11 code. The nominal transfer curve is shown in Figure 6.

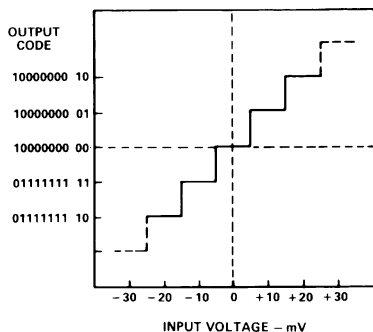

Figure 6. AD573 Transfer Curve—Bipolar Operation

Note that in the bipolar mode, the code transitions are offset $1/2$ LSB such that an input voltage of $0\text{ volts} \pm 5\text{ mV}$ yields the code representing zero (10000000 00). Each output code is then centered on its nominal input voltage.

Full-Scale Calibration

Full-Scale Calibration is accomplished in the same manner as in unipolar operation except the full scale input voltage is $+4.985$ volts.

Negative Full-Scale Calibration

The circuit in Figure 4a can also be used in bipolar operation to offset the input voltage (nominally -5 V) which results in the 00000000 00 code. R2 should be omitted to obtain a symmetrical range.

The bipolar offset control input is not directly TTL compatible but a TTL interface for logic control can be constructed as shown in Figure 7.

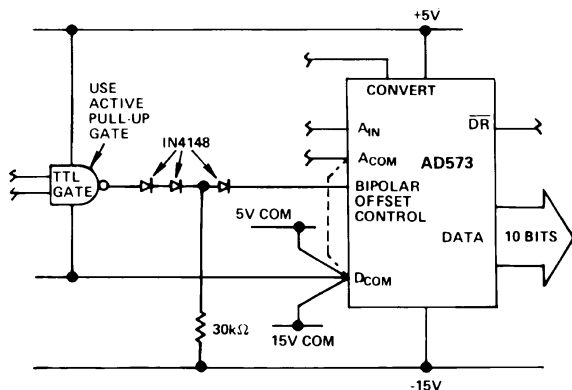

Figure 7. Bipolar Offset Controlled by Logic Gate
 Gate Output = 1 Unipolar 0–10 V Input Range
 Gate Output = 0 Bipolar $\pm 5\text{ V}$ Input Range

SAMPLE-HOLD AMPLIFIER CONNECTION TO THE AD573

Many situations in high speed acquisition systems or digitizing rapidly changing signals require a sample-hold amplifier (SHA) in front of the A/D converter. The SHA can acquire and hold a signal faster than the converter can perform a conversion. A SHA can also be used to accurately define the exact point in time at which the signal is sampled. For the AD573, a SHA can also serve as a high input impedance buffer.

Figure 8 shows the AD573 connected to the AD582 monolithic SHA for high speed signal acquisition. In this configuration, the AD582 will acquire a 10 volt signal in less than $10\text{ }\mu\text{s}$ with a droop rate less than $100\text{ }\mu\text{V/ms}$.

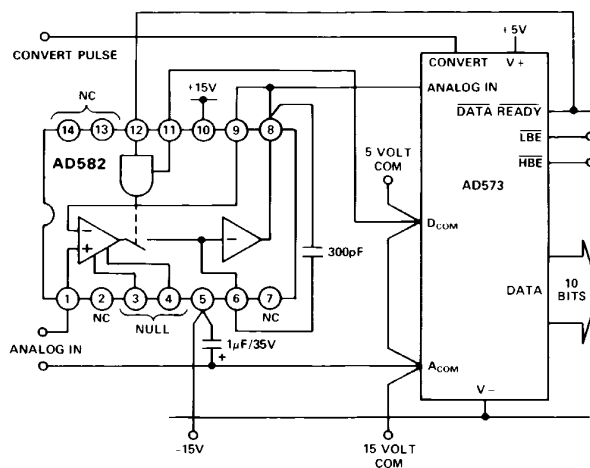

Figure 8. Sample-Hold Interface to the AD573

$\overline{\text{DR}}$ goes high after the conversion is initiated to indicate that reset of the SAR is complete. In Figure 8 it is also used to put the AD582 into the hold mode while the AD573 begins its conversion cycle. (The AD582 settles to final value well in advance of the first comparator decision inside the AD573).

$\overline{\text{DR}}$ goes low when the conversion is complete placing the AD582 back in the sample mode. Configured as shown in Figure 8, the next conversion can be initiated after a $10\text{ }\mu\text{s}$ delay to allow for signal acquisition by the AD582.

Observe carefully the ground, supply, and bypass capacitor connections between the two devices. This will minimize ground noise and interference during the conversion cycle.

GROUNDING CONSIDERATIONS

The AD573 provides separate Analog and Digital Common connections. The circuit will operate properly with as much as $\pm 200\text{ mV}$ of common-mode voltage between the two commons. This permits more flexible control of system common bussing and digital and analog returns.

In normal operation, the Analog Common terminal may generate transient currents of up to 2 mA during a conversion. In addition a static current of about 2 mA will flow into Analog Common in the unipolar mode after a conversion is complete. The Analog Common current will be modulated by the variations in input signal.

The absolute maximum voltage rating between the two commons is $\pm 1\text{ volt}$. It is recommended that a parallel pair of back-to-back protection diodes be connected between the commons if they are not connected locally.

AD573

CONTROL AND TIMING OF THE AD573

The operation of the AD573 is controlled by three inputs: $\overline{\text{CONVERT}}$, $\overline{\text{HBE}}$ and $\overline{\text{LBE}}$.

Starting a Conversion

The conversion cycle is initiated by a positive going CONVERT pulse at least 500 ns wide. The rising edge of this pulse resets the internal logic, clears the result of the previous conversion, and sets $\overline{\text{DR}}$ high. The falling edge of CONVERT begins the conversion cycle. When conversion is completed $\overline{\text{DR}}$ returns low. During the conversion cycle, $\overline{\text{HBE}}$ and $\overline{\text{LBE}}$ should be held high. If $\overline{\text{HBE}}$ or $\overline{\text{LBE}}$ goes low during a conversion, the data output buffers will be enabled and intermediate conversion results will be present on the data output pins. This may cause bus conflicts if other devices in a system are trying to use the bus.

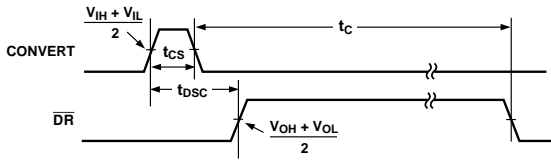

Figure 9. Convert Timing

Reading the Data

The three-state data output buffers are enabled by $\overline{\text{HBE}}$ and $\overline{\text{LBE}}$. Access time of these buffers is typically 150 ns (250 maximum). The data outputs remain valid until 50 ns after the enable signal returns high, and are completely into the high impedance state 100 ns later.

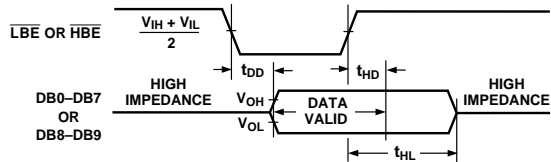

Figure 10. Read Timing

TIMING SPECIFICATIONS (All grades, $T_A = T_{\text{MIN}} - T_{\text{MAX}}$)

Parameter	Symbol	Min	Typ	Max	Units
CONVERT Pulse Width	t_{CS}	500	-	-	ns
$\overline{\text{DR}}$ Delay from CONVERT	t_{DSC}	-	1	1.5	μs
Conversion Time	t_{C}	10	20	30	μs
Data Access Time	t_{DD}	0	150	250	ns
Data Valid after $\overline{\text{HBE}}/\overline{\text{LBE}}$ High	t_{HD}	50	-	-	ns
Output Float Delay	t_{HL}	-	100	200	ns

MICROPROCESSOR INTERFACE CONSIDERATIONS—GENERAL

When an analog-to-digital converter like the AD573 is interfaced to a microprocessor, several details of the interface must be considered. First, a signal to start the converter must be generated; then an appropriate delay period must be allowed to pass before valid conversion data may be read. In most applications, the AD573 can interface to a microprocessor system with little or no external logic.

The most popular control signal configuration consists of decoding the address assigned to the AD573, then gating this signal with the system's WR signal to generate the CONVERT

pulse, and gating it with RD to enable the output buffers. The use of a memory address and memory WR and RD signals denotes "memory-mapped" I/O interfacing, while the use of a separate I/O address space denotes "isolated I/O" interfacing. In 8-bit bus systems, the 10-bit AD573 will occupy two locations when data is to be read; therefore, two (usually consecutive) addresses must be decoded. One of the addresses can also be used as the address which produces the CONVERT signal during WR operations.

Figure 11 shows a generalized diagram of the control logic for an AD573 interfaced to an 8-bit data bus, where two addresses (ADC ADDR and ADC ADDR + 1) have been decoded. ADC ADDR starts the converter when written to (the actual data being written to the converter does not matter) and contains the high byte data during read operations. ADC ADDR + 1 performs no function during write operations, but contains the low byte data during read operations.

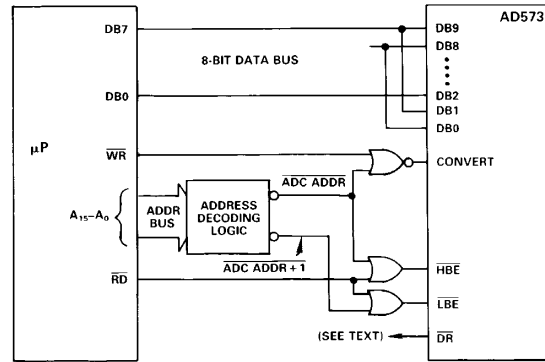

Figure 11. General AD573 Interface to 8-Bit Microprocessor

In systems where this read-write interface is used, at least 30 microseconds (the maximum conversion time) must be allowed to pass between starting a conversion and reading the results. This delay or "timeout" period can be implemented in a short software routine such as a countdown loop, enough dummy instructions to consume 30 microseconds, or enough actual useful instructions to consume the required time. In tightly-timed systems, the $\overline{\text{DR}}$ line may be read through an external three-state buffer to determine precisely when a conversion is complete. Higher speed systems may choose to use $\overline{\text{DR}}$ to signal an interrupt to the processor at the end of a conversion.

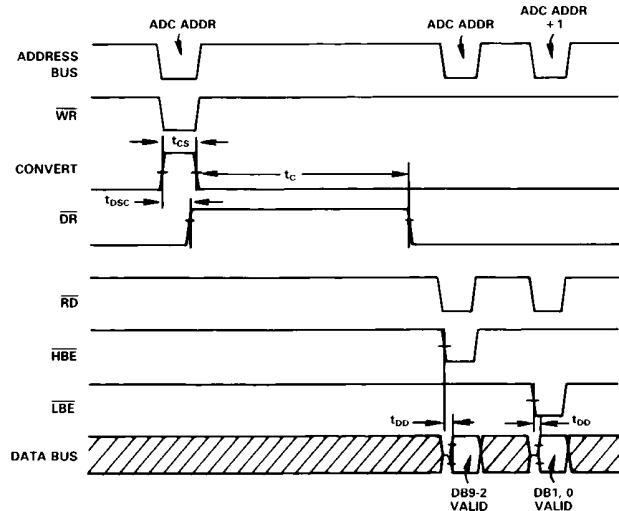

Figure 12. Typical AD573 Interface Timing Diagram

CONVERT Pulse Generation

The AD573 is tested with a CONVERT pulse width of 500 ns and will typically operate with a pulse as short as 300 ns. However, some microprocessors produce active WR pulses which are shorter than this. Either of the circuits shown in Figure 13 can be used to generate an adequate CONVERT pulse for the AD573.

In both circuits, the short low going WR pulse sets the CONVERT line high through a flip-flop. The rising edge of DR (which signifies that the internal logic has been reset) resets the flip-flop and brings CONVERT low, which starts the conversion.

Note that t_{DSC} is slightly longer when the result of the previous conversion contains a Logic 1 on the LSB. This means that the actual CONVERT pulse generated by the circuits in Figure 13 will vary slightly in width.

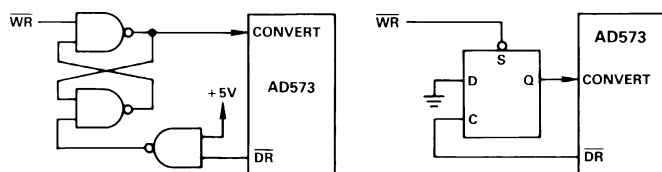

Figure 13a. Using 74LS00 Figure 13b. Using 1/2 74LS74

Output Data Format

The AD573 output data is presented in a left justified format. The 8 MSBs (DB9–DB2, Pins 10 through 3) are enabled by HBE (Pin 20) and the 2 LSBs (DB1, DB0—Pins 2 and 1) are enabled by LBE (Pin 19). This allows simple interface to 8-bit system buses by overlapping the 2 MSBs and the 2 LSBs. The organization of the data is shown in Figure 14.

When the least significant bits are read (LBE brought low), the six remaining bits of the byte will contain meaningless data. These unwanted bits can be masked by logically ANDing the byte with 11000000 (C0 hex), which forces the 6 lower bits to Logic 0 while preserving the two most significant bits of the byte.

Note that it is not possible to reconfigure the AD573 for right justified data.

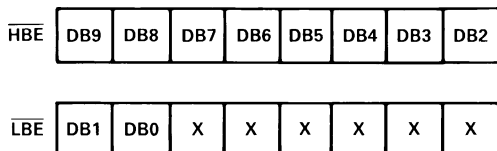

Figure 14. AD573 Output Data Format

In systems where all 10 bits are desired at the same time, $\overline{\text{HBE}}$ and $\overline{\text{LBE}}$ may be tied together. This is useful in interfacing to 16-bit bus systems. The resulting 10-bit word can then be placed at the high end of the 16-bit bus for left justification or at the low end for right justification.

It is also possible to use the AD573 in a “stand-alone” mode, where the output data buffers are automatically enabled at the end of a conversion cycle. In this mode, the $\overline{\text{DR}}$ output is wired to the $\overline{\text{HBE}}$ and $\overline{\text{LBE}}$ inputs. The outputs thus are forced into the high impedance state during the conversion period, and valid data becomes available approximately 500 ns after the $\overline{\text{DR}}$ signal goes low at the end of the conversion. The 500 ns delay allows propagation of the least significant bit through the internal logic.

This mode is particularly useful for bench-testing of the AD573, and in applications where dedicated I/O ports of peripheral interface adapter chips are available.

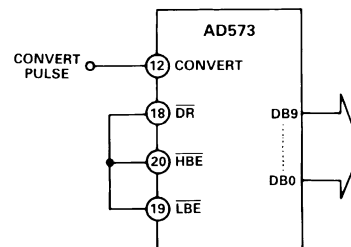

Figure 15. AD573 in “Stand-Alone” Mode (Output Data Valid 500 ns After DR Goes Low)

Apple II Microcomputer Interface

The AD573 can provide a flexible, low cost analog interface for the popular Apple II microcomputer. The Apple II, based on a 1 MHz 6502 microprocessor, meets all timing requirements for the AD573. Only a few TTL gates are required to decode the signals available on the Apple II’s peripheral connector. The recommended connections are shown in Figure 16.

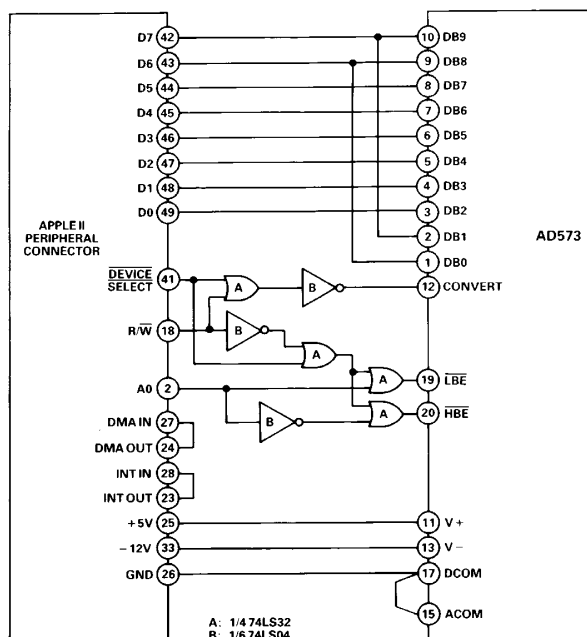

Figure 16. AD573 Interface to Apple II

The BASIC routine listed here will operate the AD573 circuit shown in Figure 16. The conversion is started by POKing to the location which contains the AD573. The relatively slow execution speed of BASIC eliminates the need for a delay routine between starting and reading the converter. This routine assumes that the AD573 is connected for a ± 5 volt input range. Variable I represents the integer value (from 0 to 1023) read from the AD573. Variable V represents the actual value of the input signal (in volts).

```

100 PRINT "WHICH SLOT IS THE A/D IN";:INPUT S
110 A=49280 + 16*S
120 POKE A,0
130 L=PEEK(A) :H=PEEK(A+1)
140 I=(4*H) + INT(L/64)
150 V=(I/1024)*10-5
160 PRINT "THE INPUT SIGNAL IS";V;"VOLTS."
    
```

AD573

It is also possible to write a faster-executing assembly-language routine to control the AD573. Such a routine will require a delay between starting and reading the converter. This can be easily implemented by calling the Apple's WAIT subroutine (which resides at location \$FCA8) after loading the accumulator with a number greater than or equal to two.

8085-Series Microprocessor Interface

The AD573 can also be used with 8085-series microprocessors. These processors use separate control signals for RD and WR, as opposed to the single R/W control signal used in the 6800/6500 series processors.

There are two constraints related to operation of the AD573 with 8085-series processors. The first problem is the width of the CONVERT pulse. The circuit shown in Figure 17 (essentially the same as that shown in Figure 13) will produce a wide enough CONVERT pulse when the 8085 is running at 5 MHz. For 8085 systems running at slower clock rates (3 MHz), the flip-flop-based circuit can be eliminated since the WR pulse will be approximately 500 ns wide.

The other consideration is the access time of the AD573's three-state output data buffers, which is 250 ns maximum. It may be necessary to insert wait states during RD operations from the AD573. This will not be a problem in systems using memories with comparable access times, since wait states will have already been provided in the basic system design.

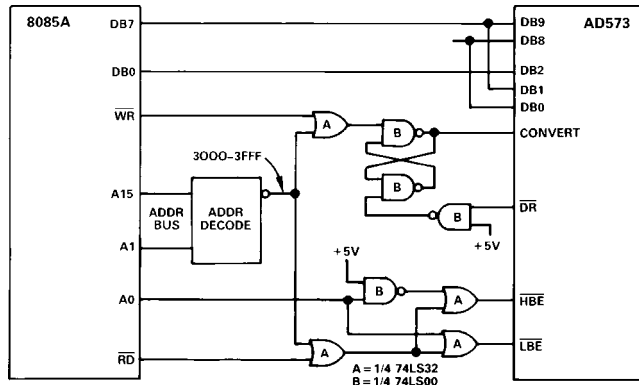

Figure 17. AD573-8085A Interface Connections

The following assembly-language subroutine can be used to control an AD573 residing at memory locations 3000_H and 3001_H. The 10 bits of data are returned (left-justified) in the DE register pair.

```

ADC:  LXI H, 3000 ; LOAD HL WITH AD573 ADDRESS
      MOV M, A   ; START CONVERSION
      MVI B, 06  ; LOAD DELAY PERIOD
LOOP: DCR B     ; DELAY LOOP
      JNZ LOOP
      MOV A, M   ; READ LOW BYTE
      ANI C0    ; MASK LOWER 6 BITS
      MOV E, A  ; STORE CLEAN LOW BYTE IN E
      INR L    ; LOAD HIGH BYTE ADDRESS
      MOV D, M  ; MOVE HIGH BYTE TO D
      RET      ; EXIT
    
```

OUTLINE DIMENSIONS

Dimensions shown in inches and (mm).

20-Pin Ceramic DIP Package ("D")

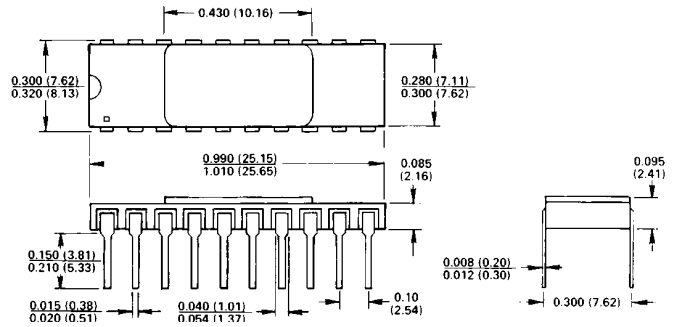

20-Pin Plastic DIP Package ("N")

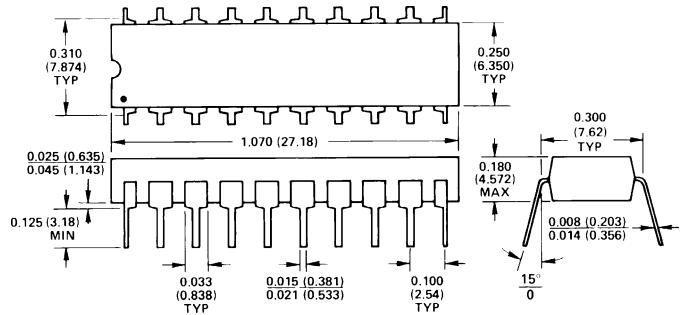

P-20A PLCC

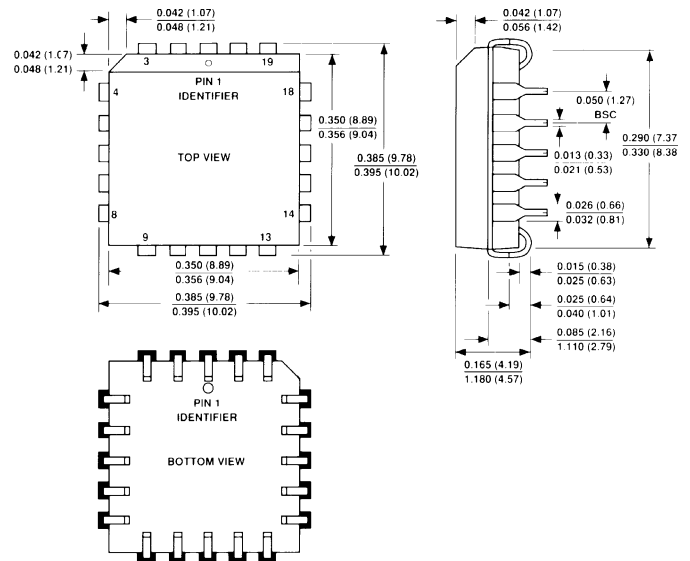



LittleDiode supplies new, hard to find or obsolete electronic components and semiconductors all over the world.

With over two million different components listed you are sure to find the part you need.

Feel free to visit us today at our online store:

LittleDiode.com

Looking forward to providing you with the best possible service.