

12-Bit multiplying D/A converter

AM6012

DESCRIPTION

The AM6012 12-bit multiplying Digital-to-Analog converter provides high-speed and 0.025% differential nonlinearity over its full commercial temperature range.

The D/A converter uses a 3-bit segment generator for the MSBs in conjunction with a 9-bit R-2R diffused resistor ladder to provide 12-bit resolution without costly trimming processes. This technique guarantees a very uniform step size (up to \pm LSB from the ideal), monotonicity to 12 bits and integral nonlinearity to 0.05% at its differential current outputs.

The dual complementary outputs of the AM6012 increase its versatility, and effectively double the peak-to-peak output swing. Digital inputs, in addition, can be configured to accept all popular logic families.

While the device requires a reference input of 1mA for a 4mA full-scale current, operation is nearly independent of power supply voltage shifts. The power supply rejection ratio is $\pm 0.001\%$ FS/% ΔV . The devices will work from +5, -12V to $\pm 18V$ rails, with as low as 230mW power consumption typical.

FEATURES

- 12-bit resolution
- Accurate to within $\pm 0.05\%$
- Monotonic over temperature
- Fast settling time, 250ns typical
- Trimless design for low cost
- Differential current outputs
- High-speed multiplying capability
- Full-scale current, 4mA (with 1mA reference)
- High output compliance voltage, -5 to +10V
- Low power consumption, 230mW

ORDERING INFORMATION

| DESCRIPTION | TEMPERATURE RANGE | ORDER CODE | DWG # |
|--|-------------------|------------|-------|
| 20-Pin Ceramic Dual In-Line Package (CERDIP) | 0 to +70°C | AM6012F | 0584B |
| 20-Pin Plastic Small Outline Large (SOL) Package | 0 to +70°C | AM6012D | 0172D |

PIN CONFIGURATION

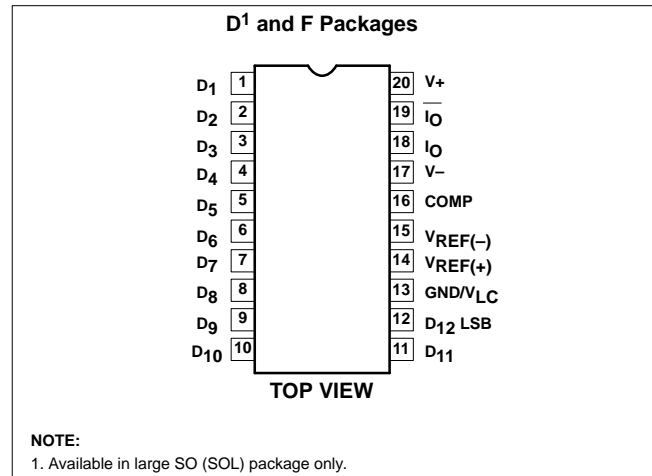

APPLICATIONS

- CRT displays, computer graphics
- Robotics and machine tools
- Automatic test equipment
- Programmable power supplies
- CAD/CAM systems
- Data acquisition and control systems
- Analog-to-digital converter systems

12-Bit multiplying D/A converter

AM6012

BLOCK DIAGRAM

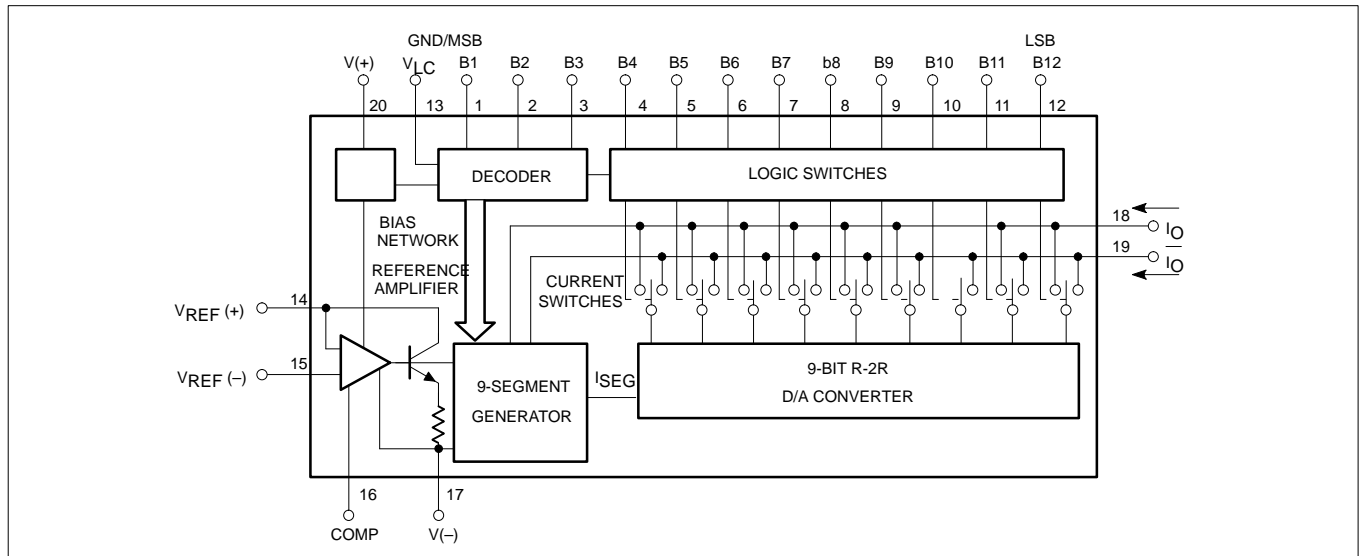

ABSOLUTE MAXIMUM RATINGS

| SYMBOL | PARAMETER | RATING | UNIT |
|------------|--|----------------|------|
| T_A | Operating temperature AM6012F | 0 to +70 | °C |
| T_{STG} | Storage temperature range | -65 to +150 | °C |
| T_{SOLD} | Lead soldering temperature 10sec max | 300 | °C |
| V_S | Power supply voltage | ±18 | V |
| | Logic inputs | -5V to +18 | V |
| | Voltage across current outputs | -8V to +12 | V |
| V_{REF} | Reference inputs V_{14} , V_{15} | V_- to V_+ | |
| V_{REF} | Reference input differential voltage (V_{14} to V_{15}) | ±18 | V |
| I_{REF} | Reference input current (I_{14}) | 1.25 | mA |
| P_D | Maximum power dissipation, $T_A=25^\circ\text{C}$, (still-air) ¹ | | |
| | F package | 1560 | mW |
| | D package | 1390 | mW |

NOTES:

- Derate above 25°C, at the following rate:
 F package at 12.5mW/°C
 D package at 11.1mW/°C

12-Bit multiplying D/A converter

AM6012

DC ELECTRICAL CHARACTERISTICSV₊=+15V, V₋=-15V, I_{REF}=1.0mA, 0°C ≤ T_A ≤ 70°C

| SYMBOL | PARAMETER | | TEST CONDITIONS | LIMITS | | | UNIT |
|------------------------------------|---------------------------|-----------|---|--------|----------|--------|--------|
| | | | | Min | Typ | Max | |
| | Resolution | | | 12 | | | Bits |
| | Monotonicity | | | 12 | | | Bits |
| DNL | Differential nonlinearity | | Deviation from ideal step size | | | ±0.025 | %FS |
| | | | | 12 | | | Bits |
| NL | Nonlinearity | | Deviation from ideal straight line | | | ±0.05 | %FS |
| I _{FS} | Full-scale current | | V _{REF} =10.000V R ₁₄ -R ₁₅ =10.000kΩ T _A =25°C | 3.935 | 3.999 | 4.063 | mA |
| TCI _{FS} | Full-scale tempco | | | | ±10 | ±40 | ppm/°C |
| | | | | | ±0.001 | ±0.004 | %FS/°C |
| V _{OC} | Output voltage compliance | | DNL Specification guaranteed over compliance range R _{OUT} >10MΩ typ. | -5 | | +10 | V |
| I _{FSS} | Symmetry | | I _{FS} -I _{FS} | | ±0.4 | ±2.0 | μA |
| I _{ZS} | Zero-scale current | | | | | 0.10 | μA |
| V _{IL} V _{IH} | Logic input levels | Logic "0" | | | | 0.8 | V |
| | | Logic "1" | | 2.0 | | | |
| I _{IN} | Logic input current | | V _{IN} =-5 to +18V | | | 40 | μA |
| V _{IS} | Logic input swing | | V ₋ =-15V | -5 | | +18 | V |
| I _{REF} | Reference current range | | | 0.2 | 1.0 | 1.1 | mA |
| I ₁₅ | Reference bias current | | | 0 | -0.5 | -2.0 | μA |
| dl/dt | Reference input slew rate | | R _{14(eq)} =800Ω C _C =0pF | 4.0 | 8.0 | | mA/μs |
| PSSI _{FS+} | Power supply sensitivity | | V ₊ =+13.5V to +16.5V, V ₋ =-15V | | ±0.0005 | ±0.001 | %FS/% |
| PSSI _{FS-} | | | V ₋ =-13.5V to -16.5V, V ₊ =+15V | | ±0.00025 | ±0.001 | |
| V ₊ | Power supply range | | V _{OUT} =0V | 4.5 | | 18 | V |
| V ₋ | | | | -18 | | -10.8 | |
| I ₊ | Power supply current | | V ₊ =+5V, V ₋ =-15V | | 5.7 | 8.5 | mA |
| I ₋ | | | | | -13.7 | -18.0 | |
| I ₊ | | | | | 5.7 | 8.5 | |
| I ₋ | | | | | -13.7 | -18.0 | |
| P _D | Power dissipation | | V ₊ =+5V, V ₋ =-15V | | 234 | 312 | mW |
| | | | V ₊ =+15V, V ₋ =-15V | | 291 | 397 | |

AC ELECTRICAL CHARACTERISTICSV₊=+15V, V₋=-15V, I_{REF}=1.0mA, 0°C ≤ T_A ≤ 70°C

| SYMBOL | PARAMETER | | TEST CONDITIONS | LIMITS | | | UNIT |
|--------------------------------------|----------------------------|--|---|--------|-----|-----|------|
| | | | | Min | Typ | Max | |
| t _S | Settling time | | To ± 1/2LSB, all bits ON or OFF, T _A =25°C | | 250 | 500 | ns |
| t _{PLH} t _{PHL} | Propagation delay—all bits | | 50% to 50% | | 25 | 50 | ns |
| C _{OUT} | Output capacitance | | | | 20 | | pF |

12-Bit multiplying D/A converter

AM6012

CIRCUIT DESCRIPTION

The AM6012 is a 12-bit DAC which uses diffused resistors and requires no trimming to guarantee monotonicity over the temperature range. A segmented DAC design guarantees a more uniform step size over the temperature range than is normally available with trimmed 12-bit converters. The converter features differential high compliance current outputs, wide supply range, and a multiplying reference input.

In many converter applications, uniform step size is more important than conformance to an ideal straight line. Many 12-bit converters are used for high resolution rather than high linearity, since few transducers are more linear than $\pm 0.1\%$. All classic binary weighted converters require $\pm 1/2\text{LSB}$ ($\pm 0.012\%$) linearity in order to guarantee monotonicity, which requires very tight resistor matching and tracking. The AM6012 uses conventional bipolar processing to achieve high differential linearity and monotonicity without requiring correspondingly high linearity, or conformance to an ideal straight line.

One design approach which provides monotonicity without requiring high linearity is the MOS switch-resistor string. This circuit is actually a full complement to a current-switched R-2R DAC since it is slower, has a voltage output, and, if implemented at the 12-bit level, would use 4096 low tolerance resistors rather than a minimum number of high tolerance resistors as in the R-2R network. Its lack of speed and density for 12 bits are its drawbacks.

With the segmented DAC approach, the 4096 required output levels are composed of 8 groups of 512 steps each. Each step group is generated by a 9-bit DAC, and each of the segment slopes is determined by one of 8 equal current sources. The resistors which determine monotonicity are in the 9-bit DAC. The major carry of the 9-bit DAC is repeated in each of the 8 segments, and requires eight times lower initial resistor accuracy and tracking to maintain a given differential nonlinearity over temperature.

The operation of the segmented DAC may be visualized by assuming an input code of all zeroes. The first segment current I_O is divided into 512 levels by the 9-bit multiplying DAC and fed to the output, I_{OUT} . As the input code increases, a new segment current is selected for each 512 counts. The previous segment is fed to output I_{OUT} where the new step group is added to it, thus ensuring monotonicity independent of segment resistor values. All higher order segments feed I_{OUT} .

With the segmented DAC approach, the precision of the 8 main resistors determines linearity only. The influence of each of these resistors on linearity is four times lower than that of the MSB resistor in an R-2R DAC. Hence, assuming the same resistor tolerances for both, the linearity of the segmented approach would actually be higher than that of an R-2R design.

The step generator or 9-bit DAC is composed of a master and a slave ladder. The slave ladder generates the four least significant bits from the remainder of the master ladder by active current

splitting utilizing scaled emitters. This saves ladder resistors and greatly reduces the range of emitter scaling required in the 9-bit DAC. All current switches in the step generator are high-speed fully-differential switches which are capable of switching low currents at high speed. This allows the use of a binary scaled network all the way to the least significant bit which saves power and simplifies the circuitry.

Diffused resistors have advantages over thin film resistors beyond simple economy and bipolar process compatibility. The resistors are fabricated in single crystal rather than amorphous material which gives them better long term stability and tracking and much higher moisture resistance. They are diffused at 1000°C and so are resistant to changes in value due to thermal and chemical causes. Also, no burn-in is required for stability. The contact resistance between aluminum and silicon is more predictable than between aluminum and an amorphous thin film, and no sandwich metals are required to enhance or protect the contact or limit alloying. The initial match between two diffused resistors is similar to that of thin film since both are defined by photomasks and chemical etching. Since the resistors are not trimmed or altered after fabrication, their tracking and long-term characteristics are not degraded.

DIFFERENTIAL VS INTEGRAL NONLINEARITY

Integral nonlinearity, for the purposes of the discussion, refers to the "straightness" of the line drawn through the individual response points of a data converter. Differential nonlinearity, on the other hand, refers to the deviation of the spacing of the adjacent points from a 1 LSB ideal spacing. Both may be expressed as either a percentage of full-scale output or as fractional LSBs or both. The graphs in Figure 1 define the manner in which these parameters are specified. The left graph shows a portion of the transfer curve of a DAC with $1/2\text{LSB}$ INL and the (implied) DNL spec of 1 LSB. Below this is a graphic representation of the way this would appear on a CRT screen where the AM6012 is used as a display driver. On the right is a portion of the transfer curve of a DAC specified for $1/2\text{LSB}$ INL with 1 LSB DNL specified and the graphic display below it.

One of the characteristics of an R-2R DAC in standard form is that any transition which causes a zero LSB change (i.e., the same output for two different codes) will exhibit the same output each time that transition occurs. The same holds true for transitions causing a 2 LSB change. These two problem transitions are allowable for the standard definition of monotonicity and also allow the device to be specified very tightly for INL. The major problem arising from this error type is in A/D converter implementations. Inputs producing the same output are now represented by ambiguous output codes for an identical input. Also, two LSB gaps can cause large errors at those input levels (assuming $1/2\text{LSB}$ quantizing levels). It can be seen from the two figures that the DNL-specified D/A converter will yield much finer grained data than the INL-specified part, thus improving the ability of the A/D to resolve changes in the analog input.

12-Bit multiplying D/A converter

AM6012

DIFFERENTIAL LINEARITY COMPARISON

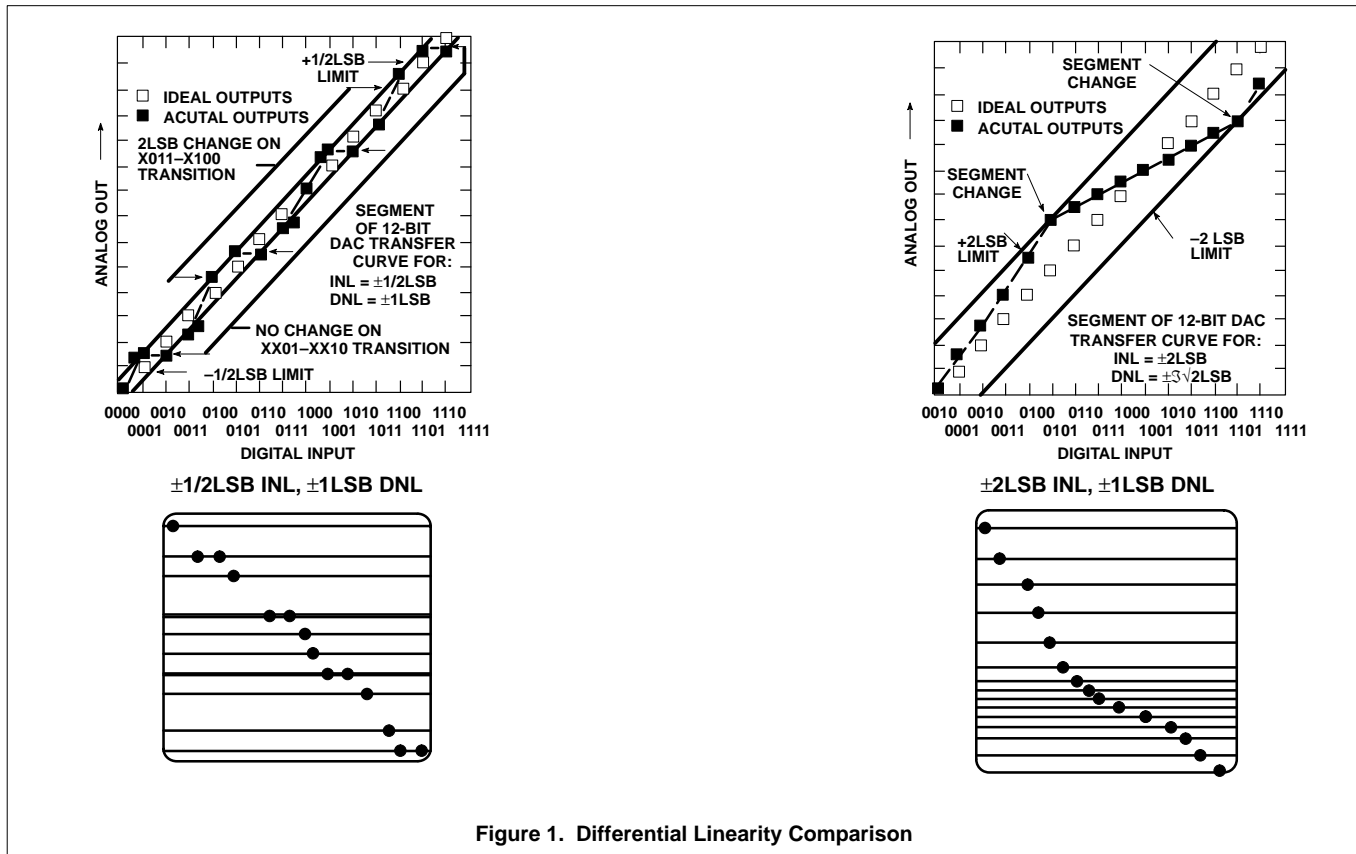

ANALOG OUTPUT CURRENTS

Both true and complemented output sink currents are provided where $I_O + \bar{I}_O = I_{FR}$. Current appears at the “true” output when a “1” is applied to each logic input. As the binary count increases, the sink current at Pin 18 increases proportionally, in the fashion of a “positive logic” D/A converter. When a “0” is applied to any input bit, that current is turned off at Pin 18 and turned on at Pin 19. A decreasing logic count increases \bar{I}_O as in a negative or inverted logic D/A converter. Both outputs may be used simultaneously. If one of the outputs is not required, it must still be connected to ground or to a point capable of sourcing I_{FR} ; do not leave an unused output pin open.

Both outputs have an extremely wide voltage compliance enabling fast direct current-to-voltage conversion through a resistor tied to ground or other voltage source. Positive compliance is 25V above V_+ and is independent of the positive supply. Negative compliance is +10V above V_- .

The dual outputs enable double the usual peak-to-peak load swing when driving loads in quasi-differential fashion. This feature is especially useful in cable driving, CRT deflection and in other balanced applications such as driving center-tapped coils and transformers.

POWER SUPPLIES

The AM6012 operates over a wide range of power supply voltages from a total supply of 20V to 36V. When operating with V_- supplies of -10V or less, $I_{REF} \leq 1\text{mA}$ is recommended. Low reference current operation decreases power consumption and increases negative

compliance, reference amplifier negative common-mode range, negative logic input range, and negative logic threshold range; consult the various figures for guidance. For example, operation at -9V with $I_{REF} = 1\text{mA}$ is not recommended because negative output compliance would be reduced to near zero. Operation from lower supplies is possible, however at least 8V total must be applied to insure turn-on of the internal bias network.

Symmetrical supplies are not required, as the AM6012 is quite insensitive to variations in supply voltage. Battery operation is feasible as no ground connection is required; however, an artificial ground may be used to insure logic swings, etc., remain between acceptable limits.

TEMPERATURE PERFORMANCE

The nonlinearity and monotonicity specifications of the AM6012 are guaranteed to apply over the entire rated operating temperature range. Full-scale output current drift is tight, typically $\pm 10\text{ppm}/^\circ\text{C}$, with zero-scale output current and drift essentially negligible compared to $1/2\text{LSB}$.

The temperature coefficient of the reference resistor R_{14} should match and track that of the output resistor for minimum overall full-scale drift.

SETTLING TIME

The AM6012 is capable of extremely fast settling times, typically 250ns at $I_{REF} = 1.0\text{mA}$. Judicious circuit design and careful board layout must be employed to obtain full performance potential during

12-Bit multiplying D/A converter

AM6012

testing and application. The logic switch design enables propagation delays of only 25ns for each of the 12 bits. Settling time to within LSB of the LSB is therefore 25ns, with each progressively larger bit taking successively longer. The MSB settles in 250ns, thus determining the overall settling time of 250ns. Settling to 10-bit accuracy requires about 90 to 130ns. The output capacitance of the AM6012 including the package is approximately 20pF; therefore, the output RC time constant dominates settling time if $R_L > 500\Omega$.

Settling time and propagation delay are relatively insensitive to logic input amplitude and rise and fall times, due to the high gain of the logic switches. Settling time also remains essentially constant for I_{REF} values down to 0.5mA, with gradual increases for lower I_{REF} values lies in the ability to attain a given output level with lower load resistors, thus reducing the output RC time constant.

Measurement of settling time requires the ability to accurately resolve $\pm 2\mu A$, therefore a 2.5k Ω load is needed to provide adequate drive for most oscilloscopes. At I_{REF} values of less than 0.5mA, excessive RC damping of the output is difficult to prevent while maintaining adequate sensitivity. However, the major carry from 011111111111 to 100000000000 provides an accurate indicator of settling time. This code change does not require the normal 6.2 time constants to settle to within $\pm 0.1\%$ of the final value, and thus settling times may be observed at lower values of I_{REF} .

AM6012 switching transients or "glitches" are very low and may be further reduced by small capacitive loads at the output at a minor sacrifice in settling time.

Fastest operation can be obtained by using short leads, minimizing output capacitance and load resistor values, and by adequate bypassing at the supply, reference, and V_{LC} terminals. Supplies do not require large electrolytic bypass capacitors as the supply current drain is independent of input logic states; 0.1 μF capacitors at the supply pins provide full transient protection.

APPLICATIONS INFORMATION

Reference Amplifier Setup

The AM6012 is a multiplying D/A converter in which the output current is the product of a digital number and the input reference current. The reference current may be fixed or may vary from nearly zero to +1.0mA. The full range output current is a linear function of the reference current and is given by:

$$I_{FR} = \frac{4095}{4096} \times 4 \times (I_{REF}) = 3.999 I_{REF}$$

where $I_{REF} = I_{14}$

In positive reference applications, an external positive reference voltage forces current through R_{14} into the $V_{REF(+)}$ terminal (Pin 14) of the reference amplifier. Alternatively, a negative reference may be applied to $V_{REF(-)}$ at Pin 15. Reference current flows from ground through R_{14} into $V_{REF(+)}$ as in the positive reference case. This negative reference connection has the advantage of a very high impedance presented at Pin 15. The voltage at Pin 14 is equal to and tracks the voltage at Pin 15 due to the high gain of the internal reference amplifier. R_{15} (nominally equal to R_{14}) is used to cancel bias current errors (Figure 2a).

Bipolar references may be accommodated by offsetting V_{REF} or Pin 15. The negative common-mode range of the reference amplifier is given by: $V_{CM-} = V_-$ plus $(I_{REF} \times 3k\Omega)$ plus 1.8V. The positive common-mode range is V_+ less 1.23V.

When a DC reference is used, a reference bypass capacitor is recommended. A 5.0V TTL logic supply is not recommended as a reference. If a regulated power supply is used as a reference, R_{14} should be split into two resistors with the junction bypassed to ground with a 0.1 μF capacitor.

For most applications, the tight relationship between I_{REF} and I_{FS} will eliminate the need for trimming I_{REF} . If required, full-scale trimming may be accomplished by adjusting the value of R_{14} , or by using a potentiometer for R_{14} .

MULTIPLYING OPERATION

The AM6012 provides excellent multiplying performance with an extremely linear relationship between I_{FS} and I_{REF} over a range of 1mA to 1 μA . Monotonic operation is maintained over a typical range of I_{REF} from 100 μA to 1.0mA.

REFERENCE AMPLIFIER COMPENSATION FOR MULTIPLYING APPLICATIONS

reference applications will require the reference amplifier to be compensated using a capacitor from pin 16 to V_- . The value of this capacitor depends on the impedance presented to Pin 14. For R_{14} values of 1.0, 2.5 and 5.0k Ω , minimum values of C_C are 5, 12 and 25pF. Larger values of R_{14} require proportionately increased values of C_C for proper phase margin (see Figure 2b).

For fastest response to a pulse, low values of R_{14} enabling small C_C values should be used. If Pin 14 is driven by a high impedance such as a transistor current source, none of the above values will suffice and the amplifier must be heavily compensated which will decrease overall bandwidth and slew rate. For $R_{14} = 1k\Omega$ and $C_C = 5pF$, the reference amplifier slews at 4mA/ms enabling a transition from $I_{REF} = 0$ to $I_{REF} = 1mA$ in 250ns.

Operation with pulse inputs to the reference amplifier may be accommodated by an alternate compensation scheme. This technique provides lowest full-scale transition times. An internal clamp allows quick recovery of the reference amplifier from a cutoff ($I_{REF} = 0$) condition. Full-scale transition (0 to 1mA) occurs in 62.5ns when the equivalent impedance at Pin 14 is 800 Ω and $C_C = 0$. This yields a reference slew rate of 8mA/ μs which is relatively independent of R_{IN} and V_{IN} values.

LOGIC INPUTS

The AM6012 design incorporates a unique logic input circuit which enables direct interface to all popular logic families and provides maximum noise immunity. This feature is made possible by the large input swing capability, 40 μA logic input current, and completely adjustable logic threshold voltage. For $V_- = -15V$, the logic inputs may swing between -5 and +10V. This enables direct interface with +15V CMOS logic, even when the AM6012 is powered from a +5V supply. Minimum input logic swing and minimum logic threshold voltage are given by:

$$V_- \text{ plus } (I_{REF} \times 3k\Omega) \text{ plus } 1.8V.$$

The logic threshold may be adjusted over a wide range by placing an appropriate voltage at the logic threshold control pin (Pin 13, V_{LC}). For TTL interface, simply ground Pin 13. When interfacing ECL, an $I_{REF} \leq 1mA$ is recommended. For general setup of the logic control circuit, it should be noted that Pin 13 will sink 1.1mA typical. External circuitry should be designed to accommodate this current (Figure 3).

12-Bit multiplying D/A converter

AM6012

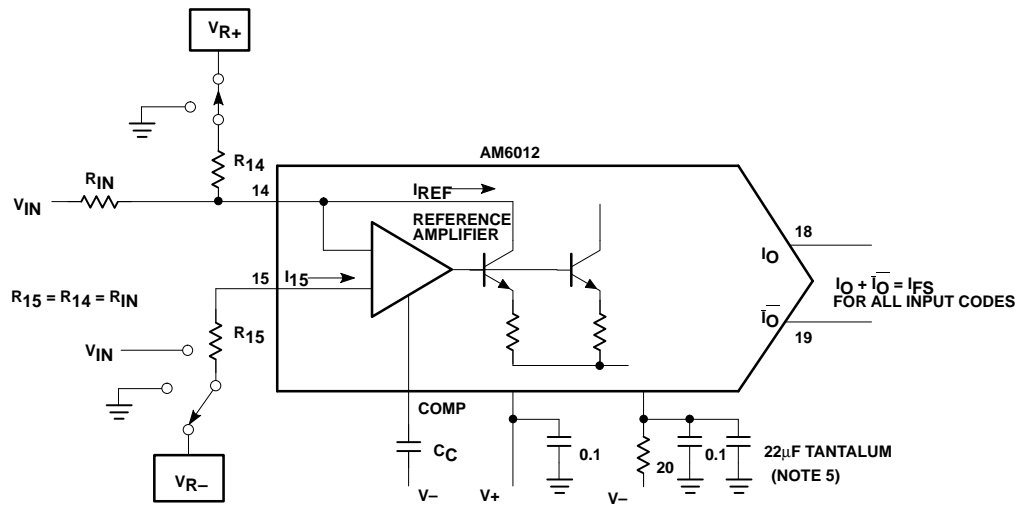

| REFERENCE CONFIGURATION | R ₁₄ | R ₁₅ | R _{IN} | C _C | I _{REF} |
|--------------------------------|-----------------|-----------------|------------------------------|----------------|--|
| Positive reference | V _{R+} | 0V | N/C | 0.01μF | V _{R+} /R ₁₄ |
| Negative reference | 0V | V _{R-} | N/C | 0.01μF | -V _{R-} /R ₁₄ |
| Lo impedance bipolar reference | V _{R+} | 0V | V _{IN} ¹ | | (V _{R+} /R ₁₄) + (V _{IN} /R _{IN}) ² |
| Hi impedance bipolar reference | V _{R+} | V _{IN} | N/C ¹ | | (V _{R+} - R _{IN}) / R ₁₄ ³ |
| Pulsed reference ⁴ | V _{R+} | 0V | V _{IN} | No Cap | (V _{R+} /R ₁₄) + (V _{IN} /R _{IN}) |

NOTES:

- The compensation capacitor is a function of the impedance seen at the +V_{REF} input and must be at least 5pF x R₁₄(eq) in kΩ. For R₁₄ < 800Ω no capacitor is necessary.
- For negative values of V_{IN}, V_{R+} / R₁₄ must be greater than -V_{IN} max / R_{IN} so that the amplifier is not turned off.
- For positive values of V_{IN}, V_{R+} must be greater than -V_{IN} max so the amplifier is not turned off.
- For pulsed operation, V_{R+} provides a DC offset and may be set to zero in some cases. The impedance at Pin 14 should be 800Ω or less.
- For optimum settling time, decouple V- with 20Ω and bypass with 22μF tantalum capacitor.
- Reference current and reference resistor — there is a 1-to-4 scale factor between the reference current (I_{REF}) and the full-scale output current (IFS).

If V_{REF} = +10V and I_{FS} = 4mA, the value of the R₁₄ is:

$$R_{14} = \frac{4 \times 10V}{4mA} = 10k\Omega \quad R_{14} = R_{15}$$

a. Reference Amplifier Biasing

Minimum Size Compensation Capacitor
(I_{FS} = 4mA, I_{REF} = 1.0mA)

| R ₁₄ (EQ) (kΩ) | C _C (pF) |
|---------------------------|---------------------|
| 10 | 50 |
| 5 | 25 |
| 2 | 10 |
| 1 | 5 |
| .5 | 0 |

NOTE:

A 0.01μF capacitor is recommended for fixed reference operation.

Reference Amplifier Frequency Response

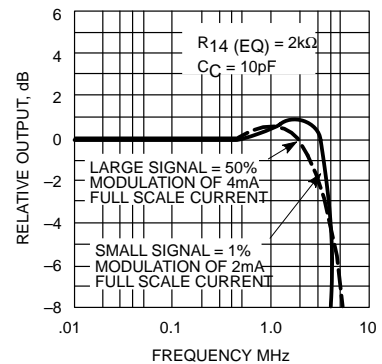

b.

Figure 2.

12-Bit multiplying D/A converter

AM6012

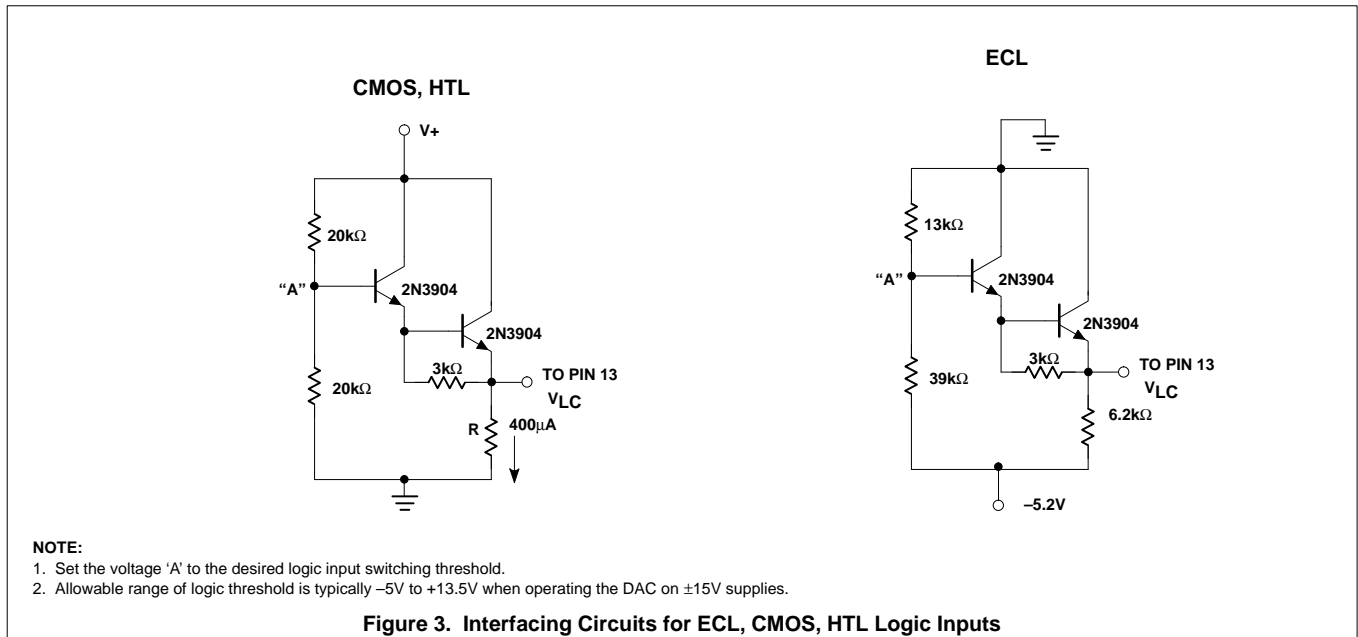

ACCOMMODATING BIPOLAR REFERENCE

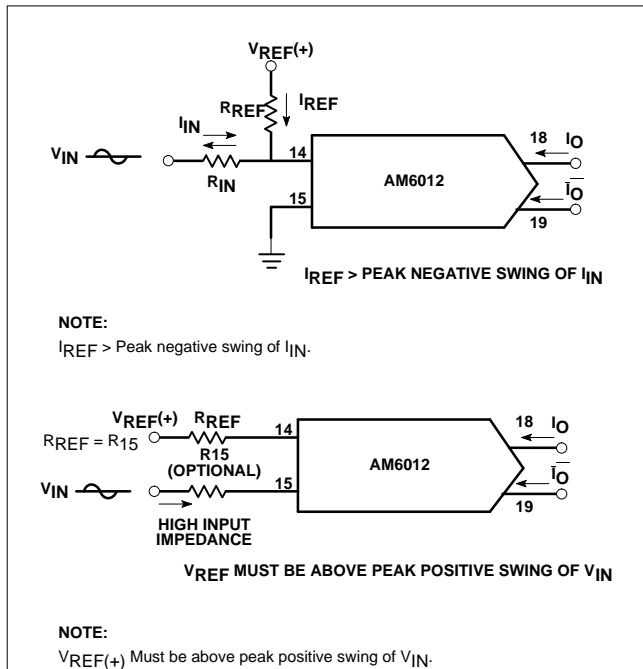

BASIC NEGATIVE REFERENCE OPERATION

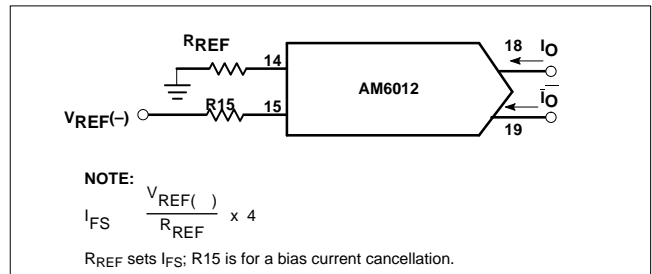

RECOMMENDED FULL-SCALE ADJUSTMENT CIRCUIT

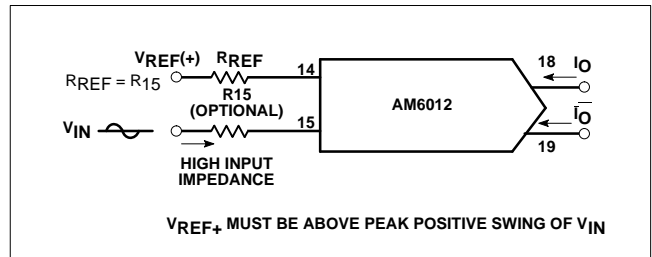

12-Bit multiplying D/A converter

AM6012

APPLICATION CIRCUITS

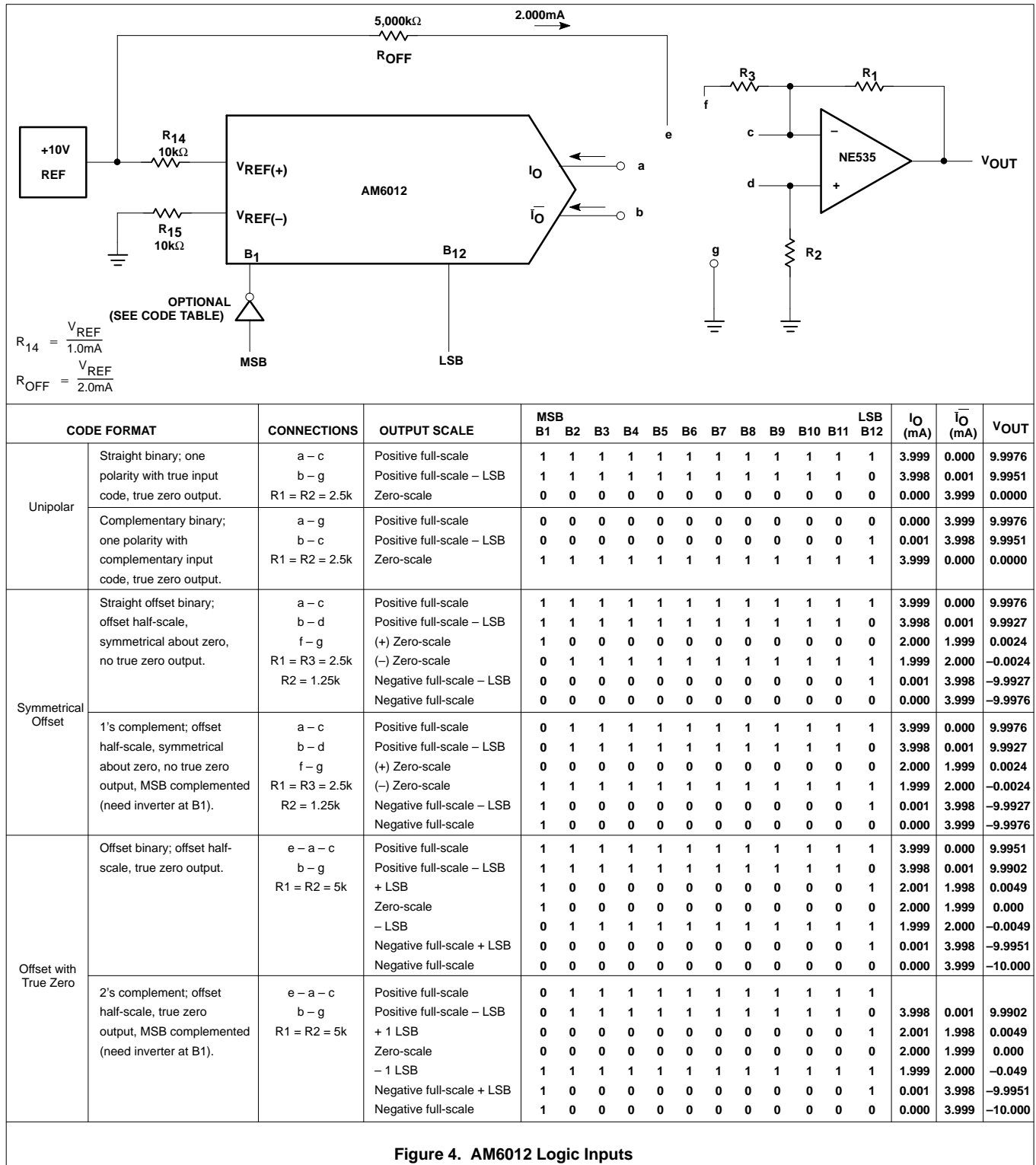

Figure 4. AM6012 Logic Inputs

ADDITIONAL CODE MODIFICATIONS

1. Any of the offset binary codes may be complemented by reversing the output terminal pair.

12-Bit multiplying D/A converter

AM6012

APPLICATION CIRCUITS

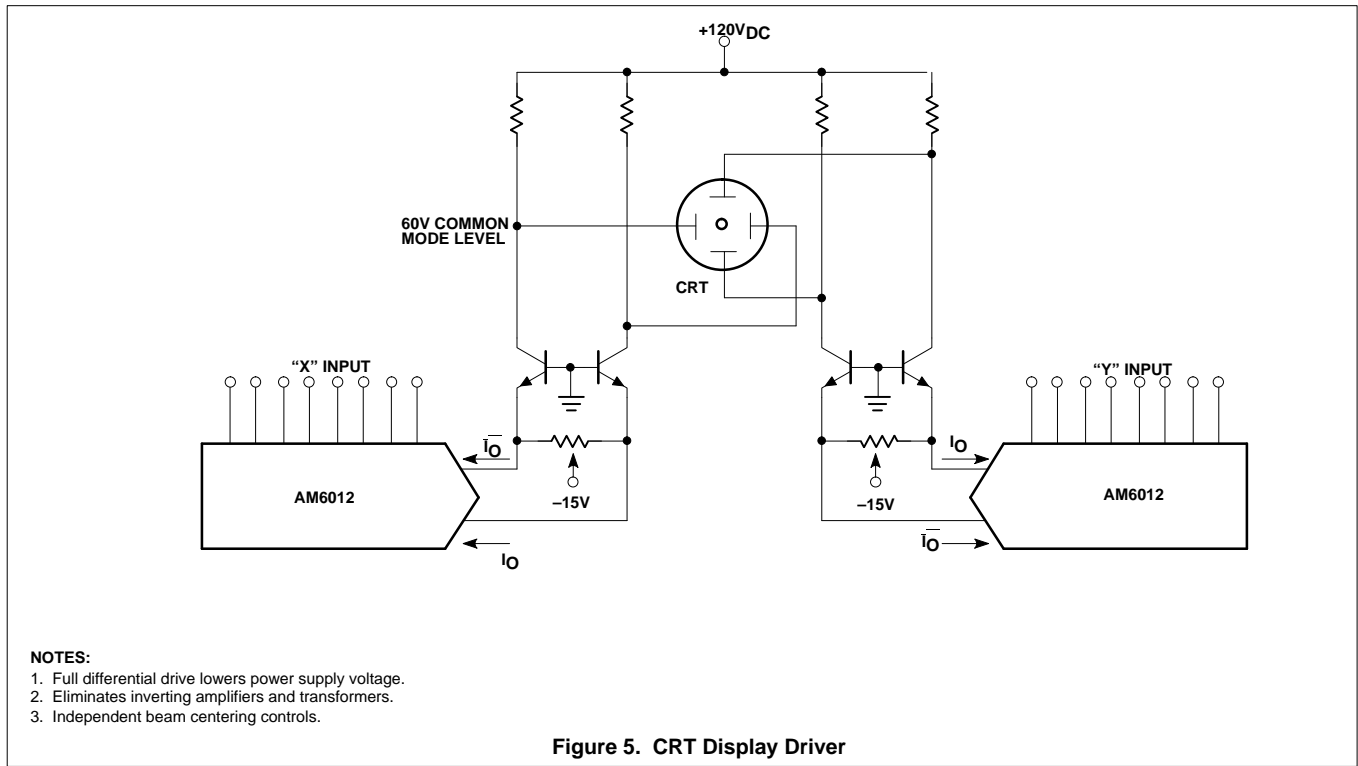

Figure 5. CRT Display Driver

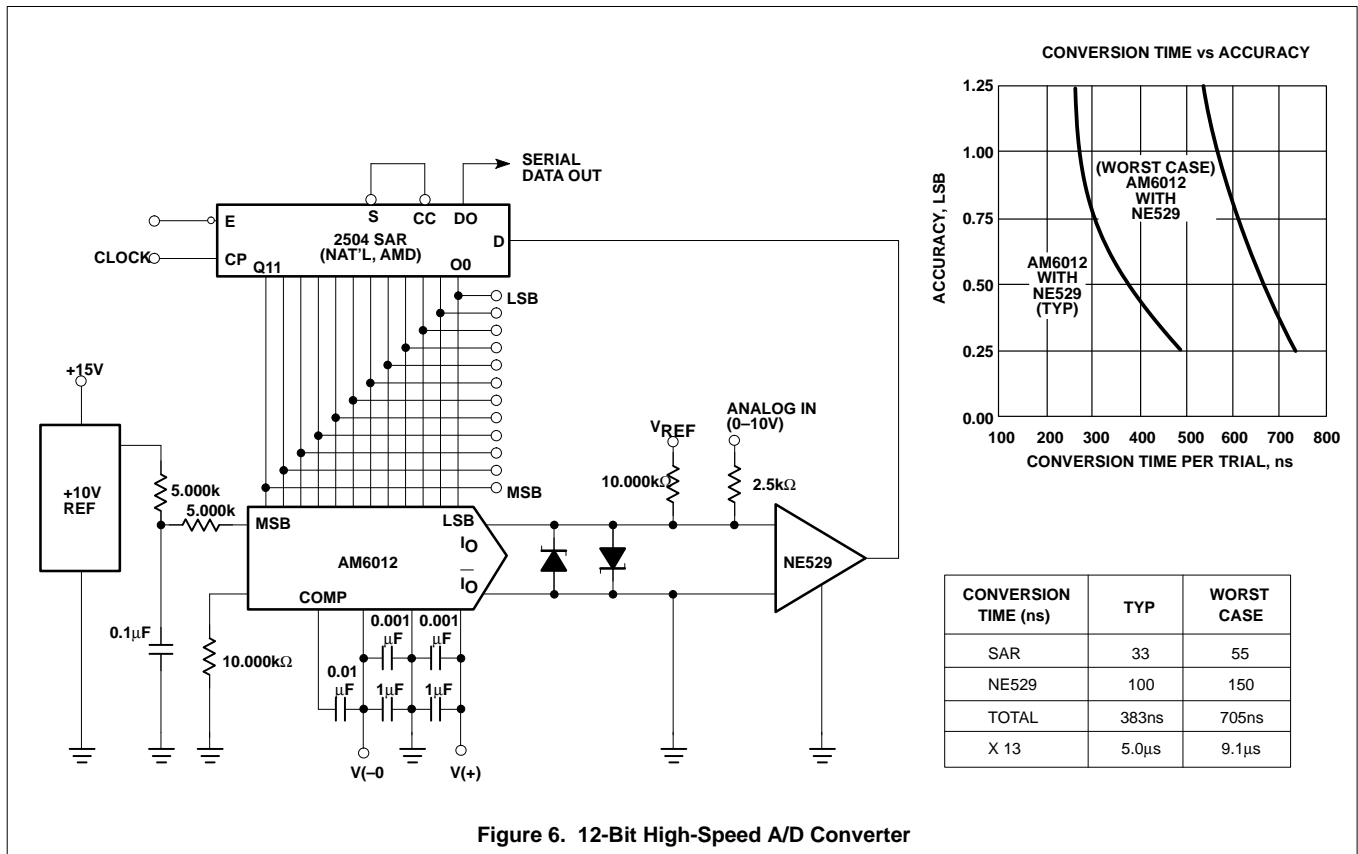
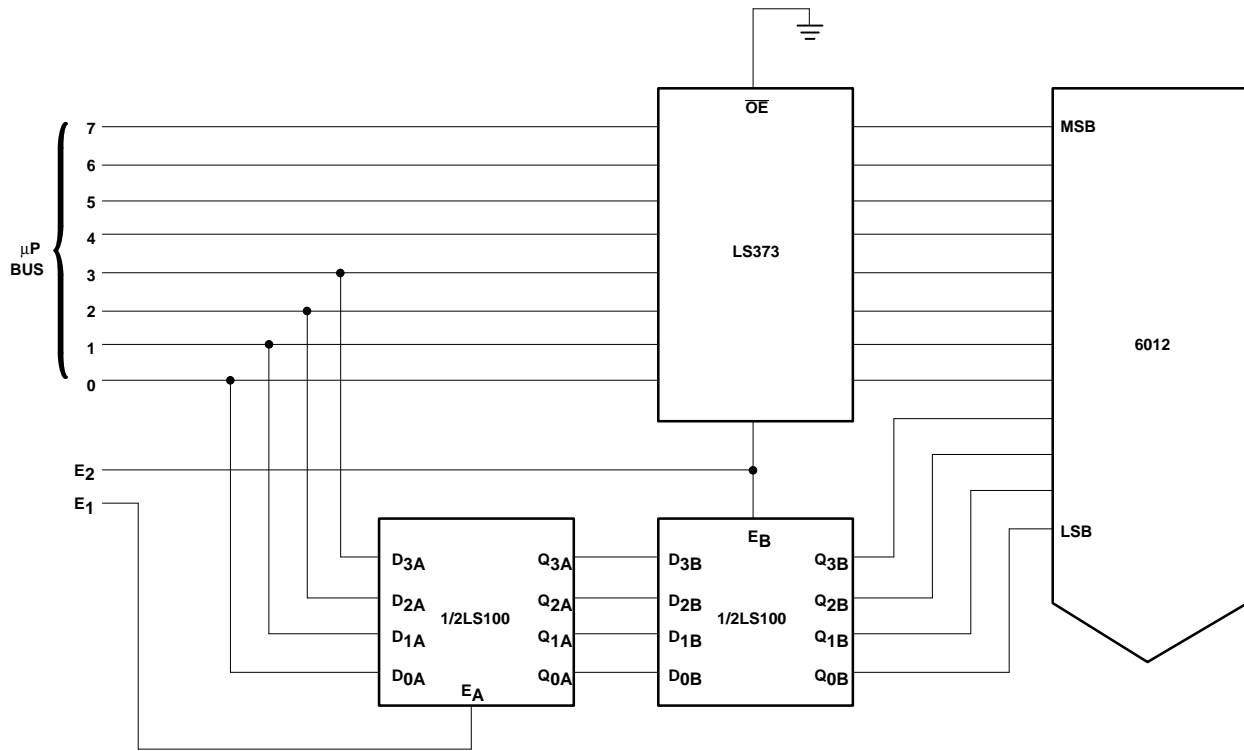

Figure 6. 12-Bit High-Speed A/D Converter

12-Bit multiplying D/A converter

AM6012

APPLICATION CIRCUITS



a. Interface With 8-Bit Microprocessor Bus

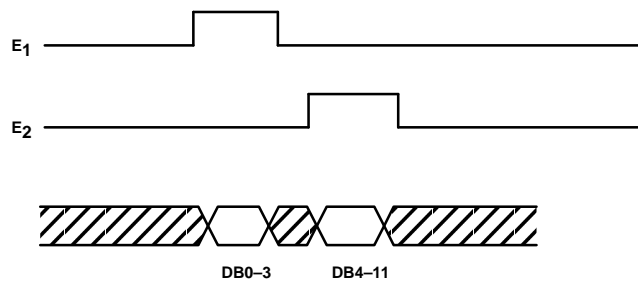

a. Timing Sequence

NOTE:
Data remains on inputs of DAC until updated by E2 pulse. Timing will depend on processor used.

Figure 7.



LittleDiode supplies new, hard to find or obsolete electronic components and semiconductors all over the world.

With over two million different components listed you are sure to find the part you need.

Feel free to visit us today at our online store:

LittleDiode.com

Looking forward to providing you with the best possible service.