

12–Bit CMOS Multiplying DAC

- ± 0.5 LSB DNL and INL
- High Stability, Segmented Architecture (3 MSB's)
- Proprietary, Low TCR Thin–Film Resistor Technology
- Low Sensitivity to Output Amplifier Offset
- 2KV ESD Protection on All Digital Inputs
- Operates With +5V to +15V Power Supplies
- AD7541/7541A Replacement
- Low Cost

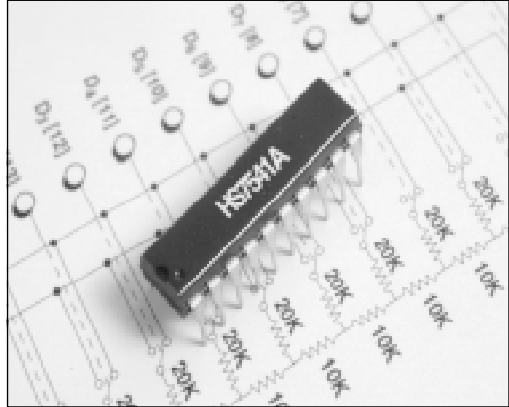

DESCRIPTION...

The **HS7541A** is a low–cost, high stability monolithic 12–bit CMOS 4–quadrant multiplying DAC. It is constructed using a proprietary low–TCR thin–film process that requires no laser–trimming to achieve 12–bit performance. The **HS7541A** is a superior pin–compatible replacement for the industry standard 7541 and AD7541A. It is available in both commercial and industrial temperature ranges. It operates with +5V to +15V power supply voltages. It is available in 18–pin plastic DIP and SOIC, and 20–pin PLCC packages.

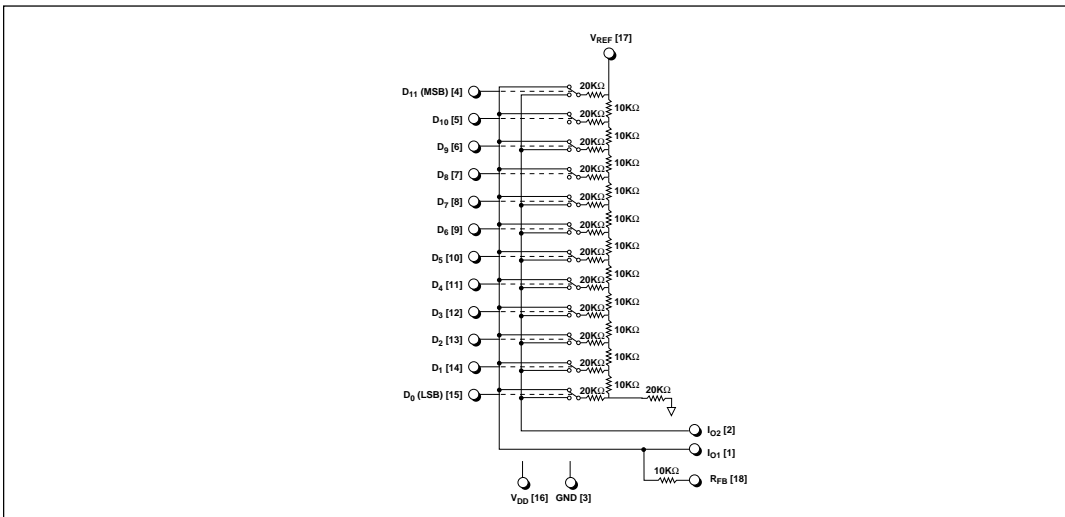

ABSOLUTE MAXIMUM RATINGS

($T_A = 25^\circ\text{C}$ unless otherwise noted.)

These are stress ratings only and functional operation of the device at these or any other above those indicated in the operation sections of the specifications below is not implied. Exposure to absolute maximum rating conditions for extended periods of time may affect reliability.

V_{DD} to GND	-0.3V, +17V
Digital Input Voltage to GND	-0.3V, V_{DD} +0.3V
V_{REF} or V_{REF} to GND	$\pm 25\text{V}$
Output Voltage (Pin 1, Pin 2)	-0.3V, V_{DD} +0.3V
Power Dissipation (Any Package to +75°C)	450mW
Derates above 75°C by	6mW/°C
Die Junction Temperature	+150°C
Storage Temperature	-65°C to +150°C
Lead Temperature (Soldering, 60 seconds)	+300°C



CAUTION:
ESD (ElectroStatic Discharge) sensitive device. Permanent damage may occur on unconnected devices subject to high energy electrostatic fields. Unused devices must be stored in conductive foam or shunts. Personnel should be properly grounded prior to handling this device. The protective foam should be discharged to the destination socket before devices are removed.

SPECIFICATIONS

($T_A = 25^\circ\text{C}$; $V_{DD} = +15\text{V}$, $V_{REF} = +10\text{V}$; $I_{O1} = I_{O2} = \text{GND} = 0\text{V}$; unipolar unless otherwise noted.)

PARAMETER	MIN.	TYP.	MAX.	UNIT	CONDITIONS
STATIC PERFORMANCE					
Resolution	12			Bits	
Integral Non-Linearity					Note 6
-AJ, -AA			± 1.0	LSB	Note 5; 11-bit relative accuracy
-AK, -AB			± 0.5	LSB	Note 5; 12-bit relative accuracy
Differential Non-Linearity					Note 7
-AJ, -AA			± 1.0	LSB	Note 5; Monotonic to 12-bits
-AK, -AB			± 0.5	LSB	Note 5; Monotonic to 12-bits
Gain Error					Note 17
-AJ, -AA			± 6	LSB	
			± 8	LSB	Note 5
-AK, -AB			± 3	LSB	
			± 5	LSB	Note 5
Output Leakage Current			± 5	nA	At I_{O1} (Pin 1); Note 18
			± 10	nA	Note 5
AC PERFORMANCE CHARACTERISTICS					
Propagation Delay		100		ns	Output Amplifier HOS-050; Note 8
Current Settling Time		0.6		μs	Note 9
Output Capacitance					Full scale transition; Note 10
$C_{I_{O1}}$ (Pin 16)			200	pF	Note 5; data inputs V_{IH}
$C_{I_{O2}}$ (Pin 15)			70	pF	Note 5; data inputs V_{IH}
$C_{I_{O1}}$ (Pin 16)			70	pF	Note 5; data inputs V_{IL}
$C_{I_{O2}}$ (Pin 15)			200	pF	Note 5; data inputs V_{IL}
Glitch Energy		1,000		nVs	Note 11
Multiplying Feedthrough Error		1.0		mV_{P-P}	Measured at output I_{O1} ; Note 12
		0.1		mV_{P-P}	Measured at output I_{O1} ; Note 13
STABILITY					
Gain Error TC		± 1.0		ppm/°C	
INL TC		± 0.1		ppm/°C	
DNL TC		± 0.1		ppm/°C	
Power Supply Rejection Ratio			± 0.02	%/%	$V_{DD} = 14$ to 16V
REFERENCE INPUT					
Input Resistance	7	10	15	K Ω	Pin 19 to GND
Input Resistance TC		± 150		ppm/°C	
Voltage Range			± 25	Volts	Note 5 and 14

SPECIFICATIONS (continued)

($T_A = 25^\circ\text{C}$; $V_{DD} = +15\text{V}$, $V_{REF} = +10\text{V}$; $I_{O1} = I_{O2} = \text{GND} = 0\text{V}$; unipolar unless otherwise noted.)

PARAMETER	MIN.	TYP.	MAX.	UNIT	CONDITIONS
DIGITAL INPUTS					
Logic Levels					
V_{IH}	2.4		V_{DD} 2.4	Volts Volts	Note 5
V_{IL}	-0.3		0.8 0.8	Volts Volts	Note 5
Input Current			± 1.0 ± 10	μA μA	$V_{IN} = 0\text{V}$ or V_{DD} Note 5 and 15
Input Capacitance Bits 1—12			8	pF	$V_{IN} = 0$; Note 5 and 14 Note 5
Coding					
Unipolar		Binary			
Bipolar		Offset Binary			
POWER REQUIREMENTS					
Voltage Range	+5		+15 +16	Volts Volts	Note 16 Note 5
Supply Current		2.0	2.5 2.5	mA mA	All digital inputs V_{IL} or V_{IH} Note 5; all digital inputs V_{IL} or V_{IH}
		0.2	0.5	mA	All digital inputs 0V or 5V to V_{DD}
			1.0	mA	Note 5; all digital inputs 0V or 5V to V_{DD}
ENVIRONMENTAL AND MECHANICAL					
Operating Temperature					
-AK, -AJ	0		+70	$^\circ\text{C}$	
-AB, -AA	-40		+85	$^\circ\text{C}$	
Storage Temperature	-65		+150	$^\circ\text{C}$	
Package					
-AK, -AJ	18-pin plastic DIP, 20-pin PLCC, 18-pin SOIC				

Notes and Cautions:

- Do not apply voltages higher than VDD or less than GND potential on any terminal other than V_{REF} or V_{RFB} .
- The digital inputs are diode-clamp protected against ESD damage. However, permanent damage may occur on unprotected units from high-energy electrostatic fields. Keep units in conductive foam at all times until ready to use.
- Use proper anti-static handling procedures.
- Stresses above those listed under "Absolute Maximum Ratings" may cause permanent damage to the device. This is a stress rating only and functional operation at or above these specifications is not implied. Exposure to the above maximum rated conditions for extended periods may affect device reliability.
- From T_{MIN} to T_{MAX} .
- Integral Non-linearity is measured as the arithmetic mean value of the magnitudes of the greatest positive deviation and the greatest negative deviation from the theoretical value of any given input combination.
- Differential Non-linearity is the deviation of an output step from the theoretical value of 1 LSB for any two adjacent digital input codes.
- AC performance characteristics are included for design guidance only and are subject to sample testing only.
- $R_L = 100\Omega$, $C_{EXT} = 13\text{pF}$; all data inputs 0V to V_{DD} or V_{DD} to 0V; from 50% digital input change to 90% of final analog output.
- Settling to $\pm 0.01\%$ FSR (strobed); all data inputs 0V to V_{DD} or V_{DD} to 0V.
- $V_{REF} = 0\text{V}$, DAC register alternatively loaded with all 0's and all 1's.
- $V_{REF} = 20V_{P-P}$; $F = 10\text{kHz}$ sinewave.
- $V_{REF} = 20V_{P-P}$; $F = 1\text{kHz}$ sinewave.
- Guaranteed by design, but not production tested.
- Logic inputs are MOS gates. I_{IN} typically is less than 1nA @ 25°C .
- Accuracy is guaranteed at $V_{DD} = +15\text{V}$ only.
- Measured using internal feedback resistor with DAC loaded with all 1's.
- All digital inputs = 0V.

PIN ASSIGNMENTS

18-Pin Plastic DIP and SOIC

- Pin 1 — I_{O1} — Inverted Current Output.
Pin 2 — I_{O2} — Current Output.
Pin 3 — GND — Analog Ground.
Pin 4 — D_{11} (MSB) — Data Bit 11 (Most Significant Bit).
Pin 5 — D_{10} — Data Bit 10.
Pin 6 — D_9 — Data Bit 9.
Pin 7 — D_8 — Data Bit 8.
Pin 8 — D_7 — Data Bit 7.
Pin 9 — D_6 — Data Bit 6.
Pin 10 — D_5 — Data Bit 5.
Pin 11 — D_4 — Data Bit 4.
Pin 12 — D_3 — Data Bit 3.
Pin 13 — D_2 — Data Bit 2.
Pin 14 — D_1 — Data Bit 1.
Pin 15 — D_0 (LSB) — Data Bit 0 (Least Significant Bit).
Pin 16 — V_{DD} — +5V to +15V Power Supply.
Pin 17 — V_{REF} — Voltage Reference Input.
Pin 18 — R_{FB} — Feedback Resistor.

20-Pin Plastic LCC

- Pin 1 — I_{O1} — Inverted Current Output.
Pin 2 — I_{O2} — Current Output.
Pin 3 — GND — Analog Ground.
Pin 4 — N.C. — No Connection.
Pin 5 — D_{11} (MSB) — Data Bit 11 (Most Significant Bit).
Pin 6 — D_{10} — Data Bit 10.
Pin 7 — D_9 — Data Bit 9.
Pin 8 — D_8 — Data Bit 8.
Pin 9 — D_7 — Data Bit 7.
Pin 10 — D_6 — Data Bit 6.
Pin 11 — D_5 — Data Bit 5.
Pin 12 — D_4 — Data Bit 4.
Pin 13 — D_3 — Data Bit 3.
Pin 14 — D_2 — Data Bit 2.
Pin 15 — D_1 — Data Bit 1.

Pin 16 — D_0 (LSB) — Data Bit 0 (Least Significant Bit).

Pin 17 — N.C. — No Connection.

Pin 18 — V_{DD} — +5V to +15V Power Supply.

Pin 19 — V_{REF} — Voltage Reference Input.

Pin 20 — R_{FB} — Feedback Resistor.

FEATURES...

The **HS7541A** is a low-cost, high stability monolithic 12-bit CMOS 4-quadrant multiplying DAC. It is constructed using a proprietary low-TCR thin-film process that requires no laser-trimming to achieve 12-bit performance. With its inherent high stability and a segmented (decoded) DAC architecture, the **HS7541A** retains its performance over time and temperature. To further improve reliability, all digital inputs are protected against 2KV ESD. Each DAC is fully characterized by all-codes testing to eliminate any hidden errors.

The **HS7541A** consists of a highly stable thin-film R-2R ladder network and twelve NMOS current switches (please refer to the *Block Diagram* on the first page of this data sheet). The switches are temperature compensated, and their “on” resistances are binarily scaled so that the voltage drop across each switch is identical, which contributes to the stability of the DAC. The internal feedback resistor used in the output current-to-voltage conversion by an external op amp is matched to the R-2R ladder.

CIRCUIT DESCRIPTION

General

The **HS7541A** is a 12-bit multiplying D/A converter consisting of a highly stable, SiChrome thin-film R-2R resistor ladder network, and twelve pairs of NMOS current-steering switches on a monolithic chip.

A simplified circuit of the **HS7541A** is shown in *Figure 1*. The R-2R inverted ladder binarily divides the input currents that are switched between the I_{OUT1} and I_{OUT2} bus lines. This switching allows a constant current to be maintained in each ladder leg independent of the input code.

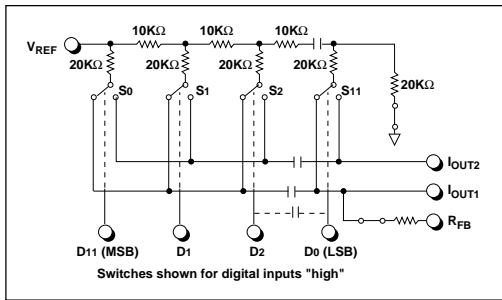

Figure 1. Simplified DAC Circuit

The twelve output current-steering switches are in series with the R-2R ladder, and therefore, can introduce bit errors. It is essential then, that the switch “on” resistance be binarily scaled so that the voltage drop across each switch remains constant. If, for example, switch S_0 of Figure 1 was designed with an “on” resistance of 10 ohms, switch S_1 for 20 ohms, etc., then with a 10V reference input, the current through S_0 is 0.5mA, S_1 is 0.25mA, etc.; a constant 5mV drop will then be maintained across each switch.

To further insure accuracy across the full temperature range, permanently “on” MOS switches are included in series with the feedback resistor and the R-2R ladder’s terminating resistor. These series switches are equivalently scaled to two times switch S_{11} (MSB) and to switch S_0 (LSB) respectively to maintain constant relative voltage drops with varying temperature. During any testing of the resistor ladder or R_{FB} (such as incoming inspection), V_{DD} must be present to turn “on” these series switches.

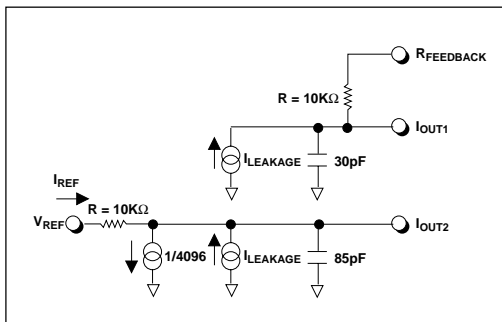

Figure 2. Equivalent Circuit – All Inputs Low

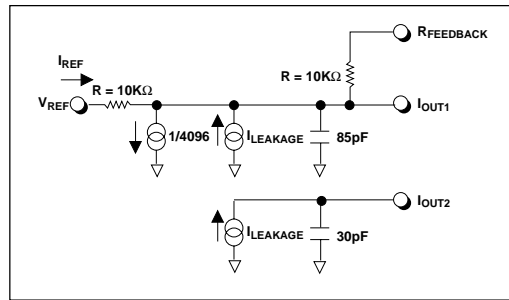

Figure 3. Equivalent Circuit – All Inputs High

2001V ESD Protection

In the design of the HS7541A’s data inputs, 2001V ESD resistance has been incorporated through careful layout and the inclusion of input protection circuitry.

Equivalent Circuit Analysis

Figures 2 and 3 show the equivalent circuits for all digital inputs LOW and HIGH respectively. The reference current is switched to I_{OUT2} when all inputs are LOW, and to I_{OUT1} when all inputs are HIGH. The $I_{LEAKAGE}$ current source is the combination of surface and junction leakages to the substrate; the 1/4096 current source represents the constant 1-bit current drain through the ladder terminating resistor. The output capacitance is dependent upon the digital input code, and therefore varies between the low and high values.

Output Impedance

The output resistance, as in the case of the output capacitance, varies with the digital input code. The resistance, looking back into the I_{OUT1} ter-

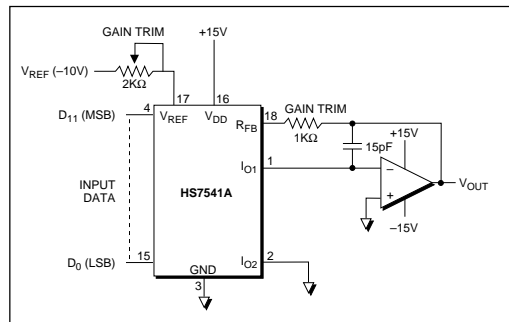

Figure 4. Unipolar Operation

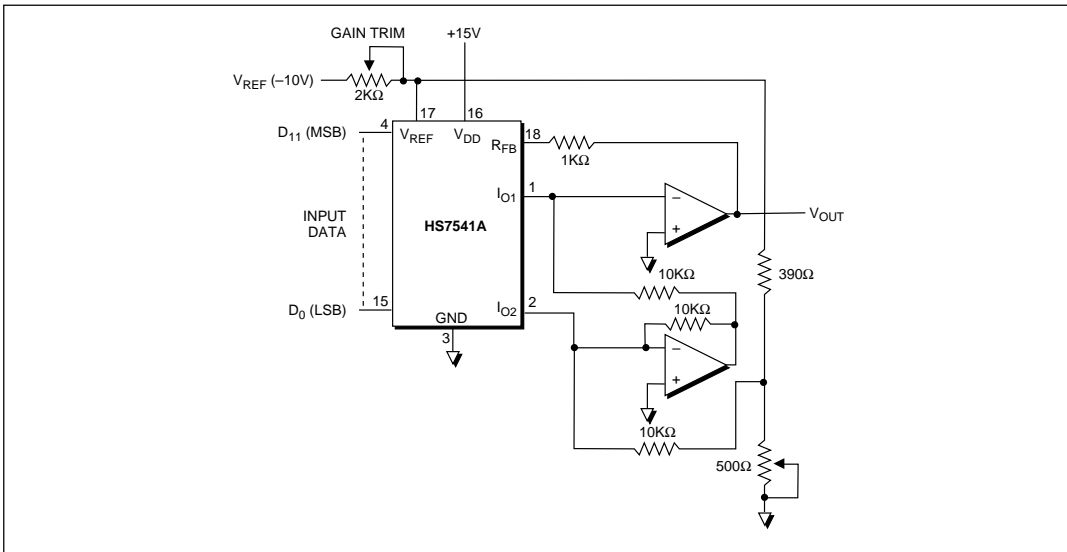

Figure 5. Bipolar Operation

minimal, may be anywhere between 10kΩ (the feedback resistor alone when all digital inputs are LOW) and 7.5kΩ (the feedback resistor in parallel with approximately 30kΩ of the R-2R ladder network resistance when any single bit is HIGH). Static accuracy and dynamic performance will be affected by these variations.

UNIPOLAR OPERATION

Figure 4 shows the connections to implement digital unipolar operation of the HS7541A. The reference voltage applied to V_{REF} (pin 17) may be positive or negative. The 2KΩ potentiometer tied to V_{REF}, and the 1KΩ resistor in the feedback loop are both optional; they are needed only when gain error must be trimmed to less than 0.3% FSR. They should track each other to better than 0.1%. It is not necessary that they track the resistors internal to the HS7541A.

DIGITAL INPUT	I _{OUT}
1111 1111 1111	-0.99975 x V _{REF}
1000 0000 0000	-0.50000 x V _{REF}
0111 1111 1111	-0.49975 x V _{REF}
0000 0000 0000	0V

Table 1. Unipolar Input Coding

As shown in the figure, the output current of the HS7541A is typically connected to an external op amp, with its non-inverting input tied to ground. The amplifier should be selected for low input bias current and low drift over temperature. To maintain the specified linearity, the amplifier's input offset voltage should be nulled to less than ±200μV (0.1 LSB).

BIPOLAR OPERATION

Figure 5 shows the connections for bipolar operation of the HS7541A. The digital input coding is offset binary as shown in Table 2. As is the case for unipolar operation, the gain trim resistors can be omitted if minimum gain error is not required. The op amp selection criteria and offset nulling are the same as for unipolar operation.

DIGITAL INPUT	I _{OUT}
1111 1111 1111	-0.99951 x V _{REF}
1000 0000 0001	-0.00049 x V _{REF}
1000 0000 0000	0V
0100 0000 0000	+0.50000 x V _{REF}
0000 0000 0000	+1.00000 x V _{REF}

Table 2. Bipolar Input Coding

ORDERING INFORMATION

Model	Relative Accuracy	Package
0°C to +70°C Operating Temperature:		
HS7541AKN	±0.5 LSB	18-Pin, 0.3" Plastic DIP
HS7541AJN	±1.0 LSB	18-Pin, 0.3" Plastic DIP
HS7541AKP	±0.5 LSB	20-Pin PLCC
HS7541AJP	±1.0 LSB	20-Pin PLCC
HS7541AKS	±0.5 LSB	18-Pin, 0.3" SOIC
HS7541AJS	±1.0 LSB	18-Pin, 0.3" SOIC
-40°C to +85°C Operating Temperature:		
HS7541ABN	±0.5 LSB	18-Pin, 0.3" Plastic DIP
HS7541AAN	±1.0 LSB	18-Pin, 0.3" Plastic DIP
HS7541ABP	±0.5 LSB	20-Pin PLCC
HS7541AAP	±1.0 LSB	20-Pin PLCC
HS7541ABS	±0.5 LSB	18-Pin, 0.3" SOIC
HS7541AAS	±1.0 LSB	18-Pin, 0.3" SOIC



SIGNAL PROCESSING EXCELLENCE

Sipex Corporation

Headquarters and Sales Office

22 Linnell Circle
 Billerica, MA 01821
 TEL: (978) 667-8700
 FAX: (978) 670-9001
 e-mail: sales@sipex.com

Sales Office

233 South Hillview Drive
 Milpitas, CA 95035
 TEL: (408) 934-7500
 FAX: (408) 935-7600

Sipex Corporation reserves the right to make changes to any products described herein. Sipex does not assume any liability arising out of the application or use of any product or circuit described hereing; neither does it convey any license under its patent rights nor the rights of others.



LittleDiode supplies new, hard to find or obsolete electronic components and semiconductors all over the world.

With over two million different components listed you are sure to find the part you need.

Feel free to visit us today at our online store:

LittleDiode.com

Looking forward to providing you with the best possible service.