

TV VERTICAL DEFLECTION OUTPUT CIRCUIT

- POWER AMPLIFIER
- FLYBACK GENERATOR
- AUTOMATIC PUMPING COMPENSATION
- THERMAL PROTECTION
- REFERENCE VOLTAGE

DESCRIPTION

The TDA8175 is a monolithic integrated circuit in HEPTAWATT package. It is a high efficiency power booster for direct driving of vertical windings of TV yokes. It is intended for use in Color and B & W television sets as well as in monitors and displays.

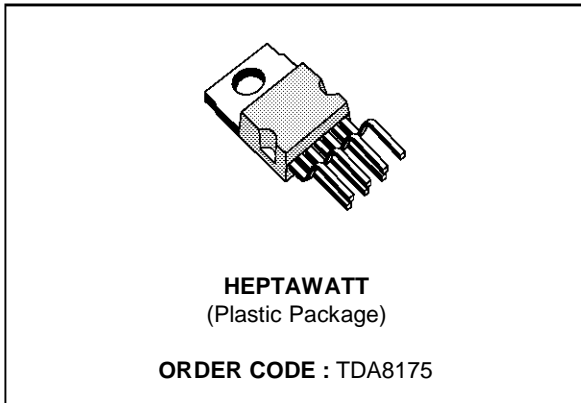

PIN CONNECTIONS

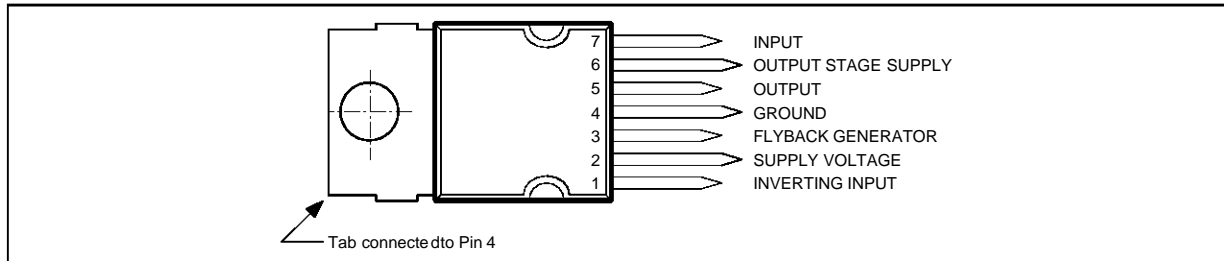

8175-01.EPS

BLOCK DIAGRAM

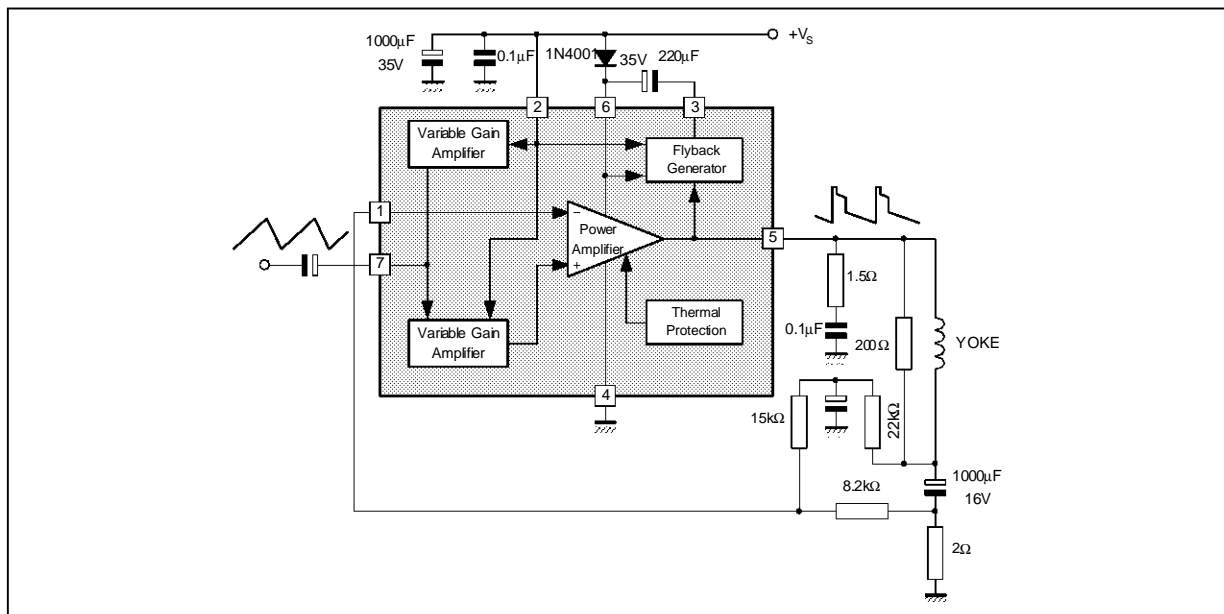

8175-02.EPS

ABSOLUTE MAXIMUM RATINGS

Symbol	Parameter	Value	Unit
V _S	Supply Voltage (PIn 2)	35	V
V ₅ , V ₆	Flyback Peak Voltage	60	V
V ₃	Voltage at PIn 3	+V _S	
V ₁ , V ₇	Amplifier Input Voltage	+V _S	
I _o	Output Peak Current (non-repetitive, t = 2ms)	2.5	A
I _o	Output Peak Current at : f = 50 or 60Hz, t ≤ 10μs f = 50 or 60Hz, t > 10μs	3 2	A A
I ₃	Pin 3 DC Current at V ₅ < V ₂	100	mA
I ₃	Pin 3 Peak-to-peak Flyback Current at f = 50 or 60Hz, t _{fly} ≤ 1.5ms	3	A
P _{tot}	Total Power Dissipation at T _{case} = 70°C	20	W
T _j , T _{stg}	Storage and Junction Temperature	-40, +150	°C

8175-01.TBL

THERMAL DATA

Symbol	Parameter	Value	Unit
R _{th(j-c)}	Junction-case Thermal Resistance	Max. 3	°C/W

8175-02.TBL

ELECTRICAL CHARACTERISTICS (V_S = 35V, T_{amb} = 25°C unless otherwise specified)

Symbol	Parameter	Test Conditions	Min.	Typ.	Max.	Unit
I ₂	Pin 2 Quiescent Current			18	36	mA
I ₆	Pin 6 Quiescent Current			16	36	mA
I ₁	Amplifier Input Bias Current	V ₁ = 1V		-0.1	-1	μA
V ₃	Pin 3 Saturation to GND	I ₃ = 20mA		1	1.5	V
V ₅	Quiescent Output Voltage	V _S = 35V, R _a = 39kΩ		19		V
V ₅	Output Saturation Voltage to GND	I ₅ = 1.2A I ₅ = 0.7A		1 0.7	1.4 1	V V
V ₅	Output Saturation Voltage to Supply	-I ₅ = 1.2A -I ₅ = 0.7A		1.6 1.3	2.2 1.8	V V
V ₀	Ramp Amplitude versus Voltage Supply	22V < V _S < 30V		4		%/V
G	AC Gain	V _S = 26V	0.54	0.61	0.67	V
V ₀	DC Output Voltage Accuracy			8		%
V ₇	Internal Bias			2.7		V
R ₇	Input Resistance			50		kΩ
T _j	Junction Temperature for Thermal Shutdown			140		°C

8175-03.TBL

THERMAL PROTECTION

The thermal protection circuit intervenes when the die temperatures reaches 150°C and turns-off the output power device.

PUMPING COMPENSATION

The device incorporates a special preamplifier, the gain of which varies with changes in supply voltage. This function allows perfect compensation of height variations caused by changes in brightness.

PACKAGE MECHANICAL DATA :9 PINS - PLASTIC HEPTAWATT

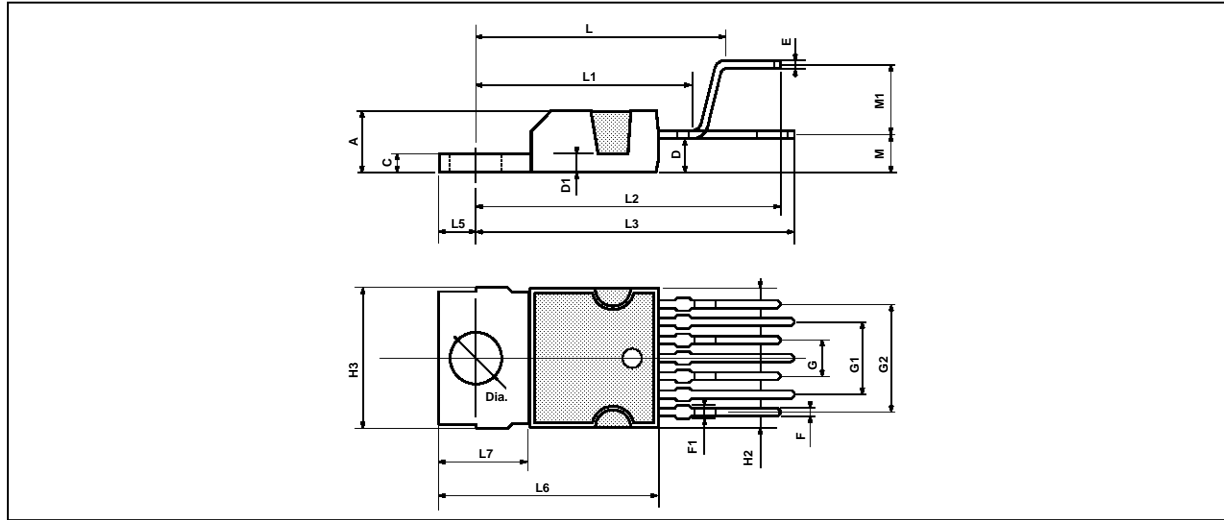

PM-HEPTV.EPS

Dimensions	Millimeters			Inches		
	Min.	Typ.	Max.	Min.	Typ.	Max.
A			4.8			0.189
C			1.37			0.054
D	2.4		2.8	0.094		0.110
D1	1.2		1.35	0.047		0.053
E	0.35		0.55	0.014		0.022
F	0.6		0.8	0.024		0.031
F1			0.9			0.035
G	2.41	2.54	2.67	0.095	0.100	0.105
G1	4.91	5.08	5.21	0.193	0.200	0.205
G2	7.49	7.62	7.8	0.295	0.300	0.307
H2			10.4			0.409
H3	10.05		10.4	0.396		0.409
L		16.97			0.668	
L1		14.92			0.587	
L2		21.54			0.848	
L3		22.62			0.891	
L5	2.6		3	0.102		0.118
L6	15.1		15.8	0.594		0.622
L7	6		6.6	0.236		0.260
M		2.8			0.110	
M1		5.08			0.200	
Dia.	3.65		3.85	0.144		0.152

HEPTV.TBL

Information furnished is believed to be accurate and reliable. However, SGS-THOMSON Microelectronics assumes no responsibility for the consequences of use of such information nor for any infringement of patents or other rights of third parties which may result from its use. No licence is granted by implication or otherwise under any patent or patent rights of SGS-THOMSON Microelectronics. Specifications mentioned in this publication are subject to change without notice. This publication supersedes and replaces all information previously supplied. SGS-THOMSON Microelectronics products are not authorized for use as critical components in life support devices or systems without express written approval of SGS-THOMSON Microelectronics.

© 1994 SGS-THOMSON Microelectronics - All Rights Reserved

Purchase of I²C Components of SGS-THOMSON Microelectronics, conveys a license under the Philips I²C Patent. Rights to use these components in a I²C system, is granted provided that the system conforms to the I²C Standard Specifications as defined by Philips.

SGS-THOMSON Microelectronics GROUP OF COMPANIES

Australia - Brazil - China - France - Germany - Hong Kong - Italy - Japan - Korea - Malaysia - Malta - Morocco
The Netherlands - Singapore - Spain - Sweden - Switzerland - Taiwan - Thailand - United Kingdom - U.S.A.