

AH5020C Monolithic Analog Current Switch

General Description

This versatile dual monolithic JFET analog switch economically fulfills a wide variety of multiplexing and analog switching applications.

These switches may be driven directly from standard 5V logic.

The monolithic construction guarantees tight resistance match and track.

Features

- Interfaces with standard TTL
- "ON" resistance match 2Ω
- Low "ON" resistance 150Ω
- Very low leakage 50 pA
- Large analog signal range ± 10V peak
- High switching speed 150 ns
- Excellent isolation between channels 80 dB at 1 kHz

Applications

- A/D and D/A converters
- Micropower converters
- Industrial controllers
- Position controllers
- Data acquisition
- Active filters
- Signal multiplexers/demultiplexers
- Multiple channel AGC
- Quad compressors/expanders
- Choppers/demodulators
- Programmable gain amplifiers
- High impedance voltage buffer
- Sample and hold

For voltage switching applications see LF13201, LF13202, LF13331, LF13332, and LF13333 Analog Switch Family, or the CMOS Analog Switch Family.

Connection and Schematic Diagrams (All switches shown are for logical "1")

Dual-In-Line Package

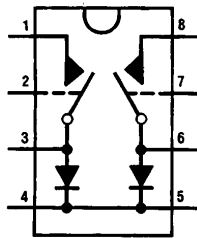

TL/H/5166-1

Top View

Order Number AH5020CJ
See NS Package Number J08A

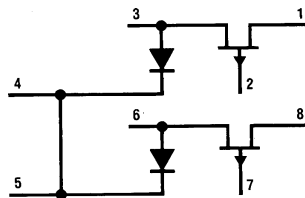

TL/H/5166-2

Note: All diode cathodes are internally connected to the substrate.

Absolute Maximum Ratings (Note 1)

If Military/Aerospace specified devices are required, please contact the National Semiconductor Sales Office/Distributors for availability and specifications.

Input Voltage	30V	Drain Current	30 mA
Positive Analog Signal Voltage	30V	Power Dissipation	500 mW
Negative Analog Signal Voltage	-15V	Operating Temp. Range	-25°C to +85°C
Diode Current	10 mA	Storage Temperature Range	-65°C to +150°C
		Lead Temp. (Soldering, 10 seconds)	300°C

Electrical Characteristics (Notes 2 and 3)

Symbols	Parameter	Conditions	Typ	Max	Units
I_{GSX}	Input Current "OFF"	$V_{GD} = 4.5V, V_{SD} = 0.7V$	0.01	0.1	nA
		$V_{GD} = 11V, V_{SD} = 0.7V$	0.01	0.2	nA
		$T_A = 85^\circ C, V_{GD} = 11V, V_{SD} = 0.7V$		10	nA
$I_{D(OFF)}$	Leakage Current "OFF"	$V_{SD} = 0.7V, V_{GS} = 3.8V$ $T_A = 85^\circ C$	0.01	0.2 10	nA nA
$I_{G(ON)}$	Leakage Current "ON"	$V_{GD} = 0V, I_S = 1 mA$ $T_A = 85^\circ C$	0.08	1 200	nA nA
$I_{G(ON)}$	Leakage Current "ON"	$V_{GD} = 0V, I_S = 2 mA$ $T_A = 85^\circ C$	0.13	5 10	nA μA
$I_{G(ON)}$	Leakage Current "ON"	$V_{GD} = 0V, I_S = -2 mA$ $T_A = 85^\circ C$	0.1	10 20	nA μA
$r_{DS(ON)}$	Drain-Source Resistance	$V_{GS} = 0.5V, I_S = 2 mA$ $T_A = +85^\circ C$	90	150 240	Ω Ω
V_{DIODE}	Forward Diode Drop	$I_D = 0.5 mA$		0.8	V
$r_{DS(ON)}$	Match	$V_{GS} = 0, I_D = 1 mA$	2	20	Ω
T_{ON}	Turn "ON" Time	See ac Test Circuit	150	500	ns
T_{OFF}	Turn "OFF" Time	See ac Test Circuit	300	500	ns
CT	Cross Talk	See ac Test Circuit	120		dB

Note 1: Absolute Maximum Ratings indicate limits beyond which damage to the device may occur. DC and AC electrical specifications do not apply when operating the device beyond its specified operating conditions.

Note 2: Test conditions 25°C unless otherwise noted.

Note 3: "OFF" and "ON" notation refers to the conduction state of the FET switch.

Note 4: Thermal Resistance:

θ_{JA} (Junction to Ambient)N/A

θ_{JC} (Junction to Case)N/A

Test Circuits

AC Test Circuit

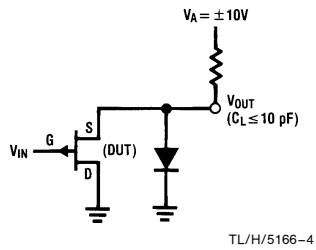

Cross Talk Test Circuit

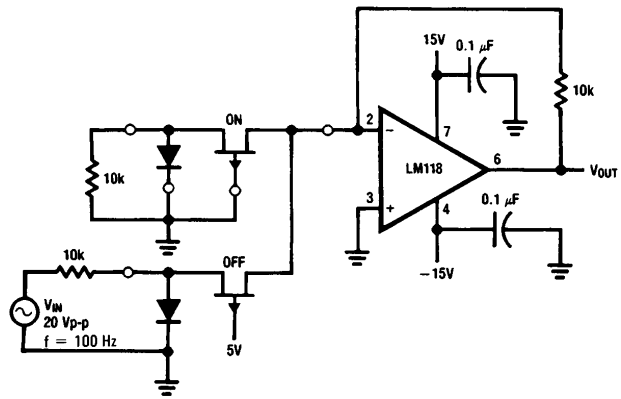

Switching Time Waveforms

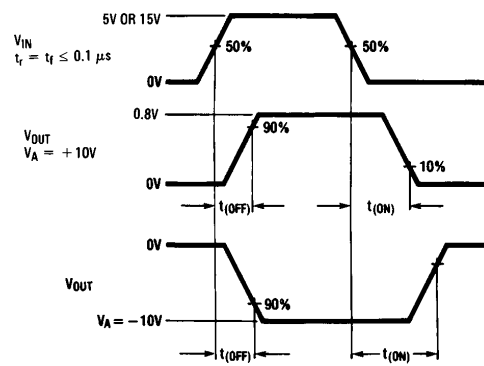

Typical Performance Characteristics

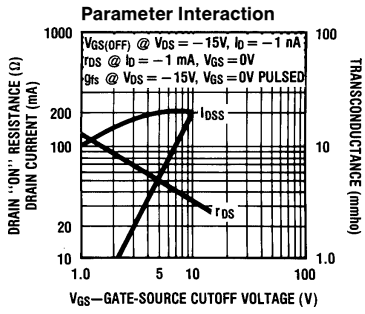

TL/H/5166-6

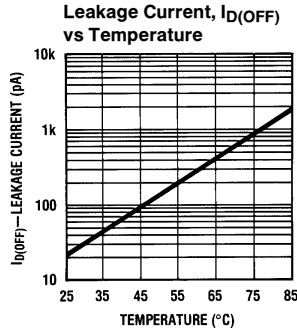

TL/H/5166-7

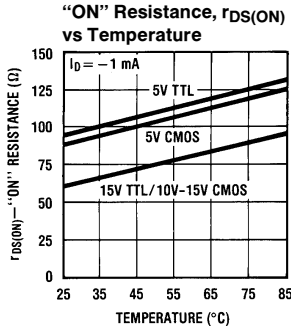

TL/H/5166-8

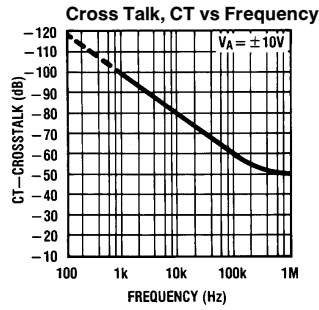

TL/H/5166-9

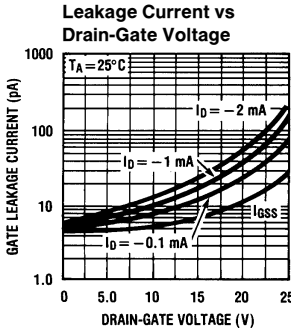

TL/H/5166-10

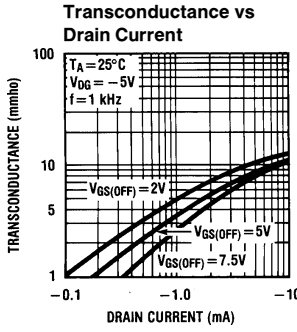

TL/H/5166-11

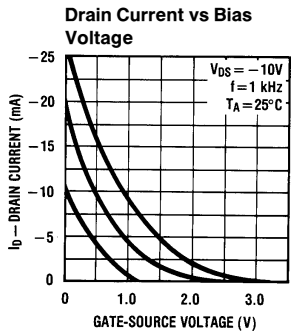

TL/H/5166-12

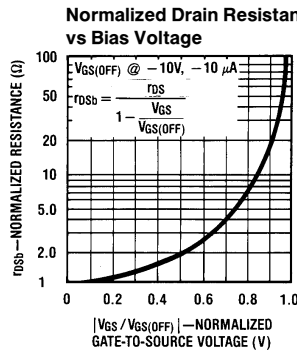

TL/H/5166-13

Applications Information

THEORY OF OPERATION

The AH5020 analog switches are primarily intended for operation in current mode switch applications; i.e., the drains of the FET switch are held at or near ground by operating into the summing junction of an operational amplifier. Limiting the drain voltage to under a few hundred millivolts eliminates the need for a special gate driver, allowing the switches to be driven directly by standard TTL.

If only one of the two switches in each package is used to apply an input signal to the input of an op amp, the other switch FET can be placed in the feedback path in order to compensate for the "ON" resistance of the switch FET as shown in *Figure 1*.

The closed-loop gain of *Figure 1* is:

$$A_{VCL} = - \frac{R_2 + r_{DS(ON)Q2}}{R_1 + r_{DS(ON)Q1}}$$

For $R_1 = R_2$, gain accuracy is determined by the $r_{DS(ON)}$ match between Q1 and Q2. Typical match between Q1 and Q2 is 2Ω resulting in a gain accuracy of 0.02% (for $R_1 = R_2 = 10 \text{ k}\Omega$).

NOISE IMMUNITY

The switches with the source diodes grounded exhibit improved noise immunity for positive analog signals in the "OFF" state. With $V_{IN} = 15\text{V}$ and the $V_A = 10\text{V}$, the source of Q1 is clamped to about 0.7V by the diode ($V_{GS} = 14.3\text{V}$) ensuring that ac signals imposed on the 10V input will not gate the FET "ON".

SELECTION OF GAIN SETTING RESISTORS

Since the AH5020 analog switches are operated in current mode, it is generally advisable to make the signal current as large as possible. However, current through the FET switch tends to forward bias the source to gate junction and the signal shunting diode resulting in leakage through these junctions. As shown in *Figure 2*, $I_{G(ON)}$ represents a finite error in the current reaching the summing junction of the op amp.

Secondly, the $r_{DS(ON)}$ of the FET begins to "round" as I_S approaches I_{DSS} . A practical rule of thumb is to maintain I_S at less than $1/10$ of I_{DSS} .

Combining the criteria from the above discussion yields:

$$R1_{(MIN)} \geq \frac{V_A(MAX) A_D}{I_{G(ON)}} \quad (2a)$$

or:

$$\geq \frac{V_A(MAX)}{I_{DSS}/10} \quad (2b)$$

whichever is larger.

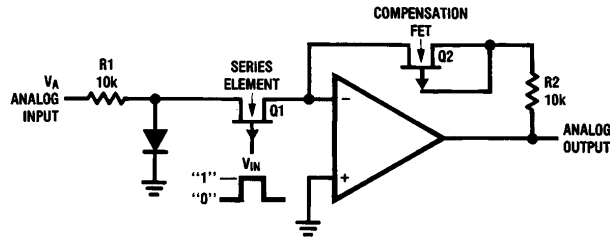

FIGURE 1. Use of Compensation FET

TL/H/5166-14

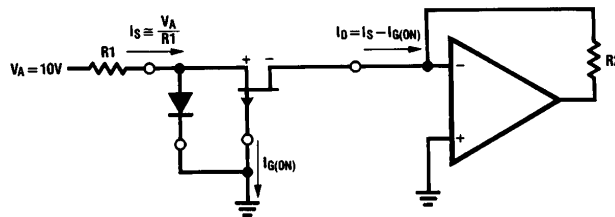

FIGURE 2. On Leakage Current, $I_{G(ON)}$

TL/H/5166-15

Applications Information (Continued)

Where $V_{A(MAX)}$ = Peak amplitude of the analog input signal

A_D = Desired accuracy

$I_{G(ON)}$ = Leakage at a given I_S

I_{DSS} = Saturation current of the FET switch
= 20 mA

In a typical application, V_A might = $\pm 10V$, $A_D = 0.1\%$, $0^\circ C \leq T_A \leq 85^\circ C$. The criterion of equation (2b) predicts:

$$R1(MIN) \geq \frac{10V}{\frac{20 \text{ mA}}{10}} = 5 \text{ k}\Omega$$

For $R1 = 5k$, $I_S \cong 10V/5k$ or 2 mA. The electrical characteristics guarantee an $I_{G(ON)} \leq 1\mu A$ at $85^\circ C$ for the AH5020. Per the criterion of equation (2a):

$$R1(MIN) \geq \frac{(10V)(10^{-3})}{1 \times 10^{-6}} \geq 10 \text{ k}\Omega$$

Since equation (2a) predicts a higher value, the 10k resistor should be used.

The "OFF" condition of the FET also affects gain accuracy. As shown in Figure 3, the leakage across Q2, $I_{D(OFF)}$ represents a finite error in the current arriving at the summing junction of the op amp.

Accordingly:

$$R1(MAX) \leq \frac{V_{A(MIN)} A_D}{(N) I_{D(OFF)}}$$

Where $V_{A(MIN)}$ = Minimum value for the analog input signal

A_D = Desired accuracy

N = Number of channels

$I_{D(OFF)}$ = "OFF" leakage of a given FET switch

As an example, if $N = 10$, $A_D = 0.1\%$, and $I_{D(OFF)} \leq 10 \text{ nA}$ at $85^\circ C$ for the AH5020. $R1(MAX)$ is:

$$R1(MAX) \leq \frac{(1V)(10^{-3})}{(10)(10 \times 10^{-9})} = 10k$$

Selection of $R2$, of course, depends on the gain desired and for unity gain $R1 = R2$.

Lastly, the foregoing discussion has ignored resistor tolerances, input bias current and offset voltage of the op amp—all of which should be considered in setting the overall gain accuracy of the circuit.

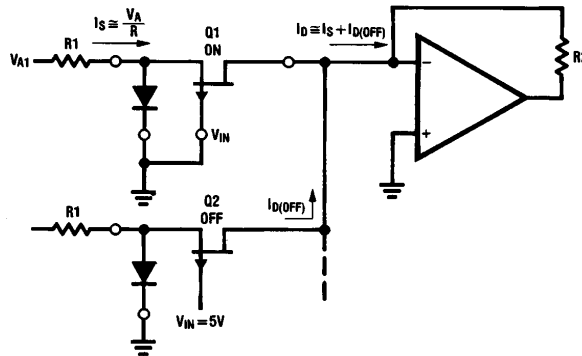

FIGURE 3. Off Leakage Current, $I_{D(OFF)}$

TL/H/5166-16

Applications Information (Continued)

TTL COMPATIBILITY

Standard TTL gates pull-up to about 3.5V (no load). In order to ensure turn-off of the AH5020, a pull-up resistor, R_{EXT} of at least 10 k Ω should be placed between the 5V V_{CC} and the gate output as shown in *Figure 4*.

DEFINITION OF TERMS

The terms referred to in the electrical characteristics tables are as defined in *Figure 5*.

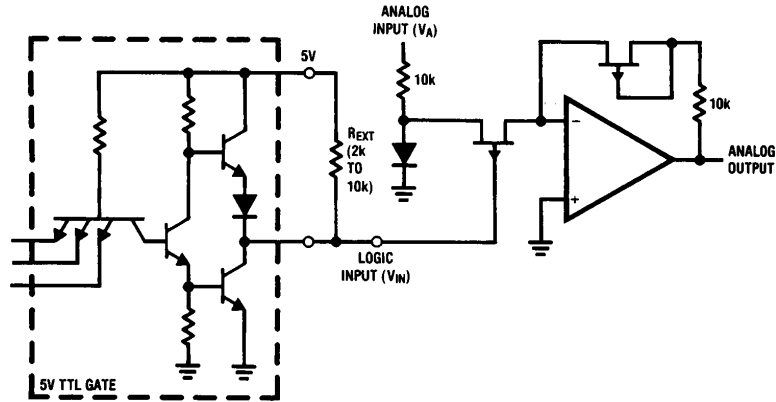

FIGURE 4. Interfacing with +5V TTL

TL/H/5166-17

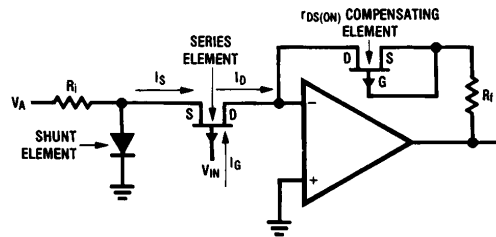
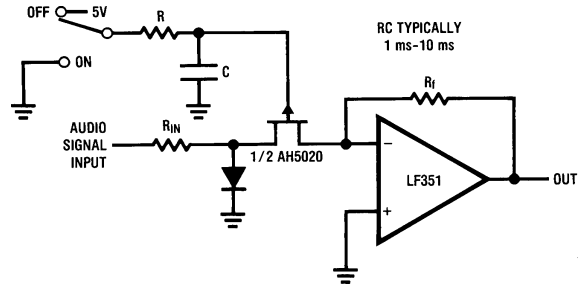

FIGURE 5. Definition of Terms

TL/H/5166-18

Typical Applications

Deglitched Switch for Noiseless Audio Switching



TL/H/5166-19

Gain Programmable Amplifier

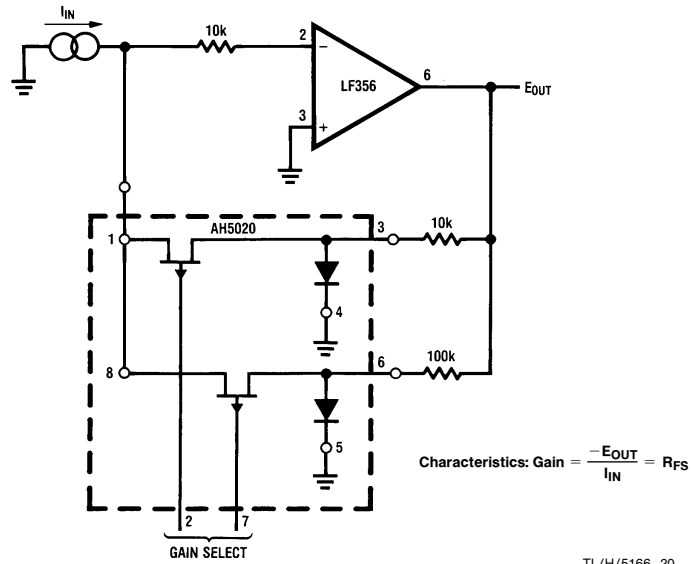

TL/H/5166-20

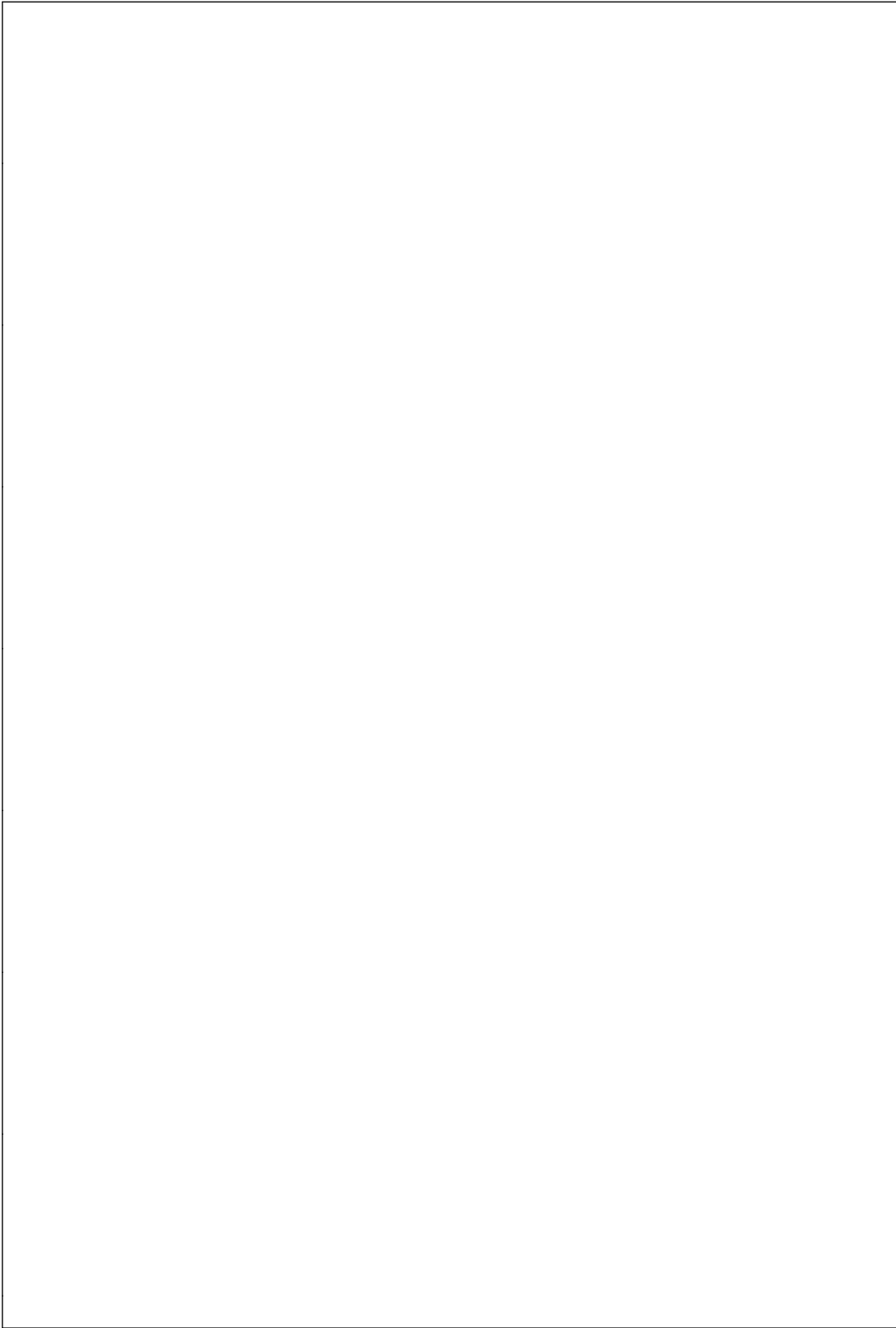

AH5020C Monolithic Analog Current Switch

Physical Dimensions inches (millimeters)

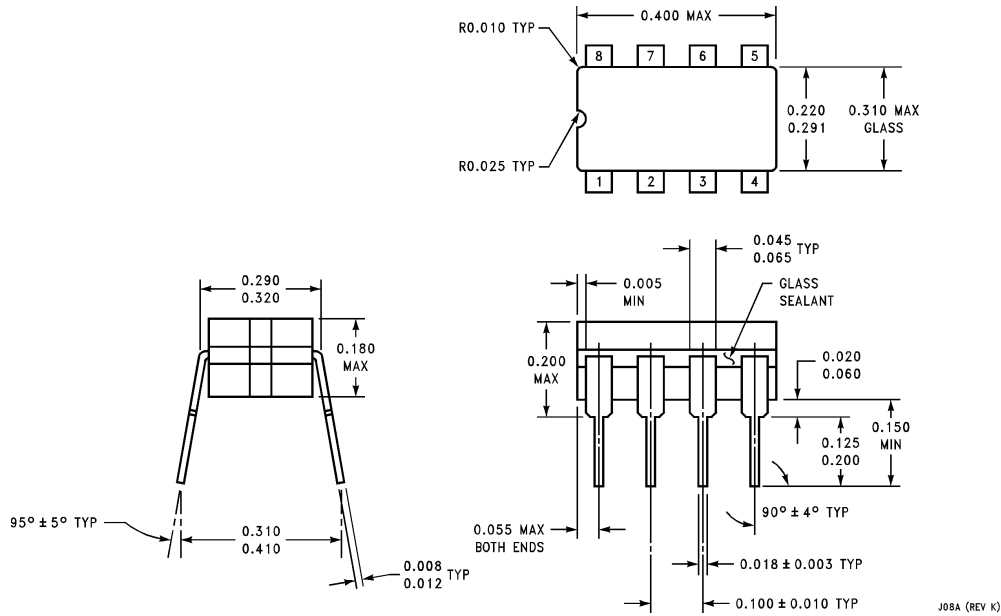

**Cavity Dual-In-Line Package (J)
Order Number AH5020CJ
NS Package Number J08A**

LIFE SUPPORT POLICY

NATIONAL'S PRODUCTS ARE NOT AUTHORIZED FOR USE AS CRITICAL COMPONENTS IN LIFE SUPPORT DEVICES OR SYSTEMS WITHOUT THE EXPRESS WRITTEN APPROVAL OF THE PRESIDENT OF NATIONAL SEMICONDUCTOR CORPORATION. As used herein:

1. Life support devices or systems are devices or systems which, (a) are intended for surgical implant into the body, or (b) support or sustain life, and whose failure to perform, when properly used in accordance with instructions for use provided in the labeling, can be reasonably expected to result in a significant injury to the user.
2. A critical component is any component of a life support device or system whose failure to perform can be reasonably expected to cause the failure of the life support device or system, or to affect its safety or effectiveness.



National Semiconductor Corporation
1111 West Bardin Road
Arlington, TX 76017
Tel: 1(800) 272-9959
Fax: 1(800) 737-7018

National Semiconductor Europe
Fax: (+49) 0-180-530 85 86
Email: cnjwge@tevm2.nsc.com
Deutsch Tel: (+49) 0-180-530 85 85
English Tel: (+49) 0-180-532 78 32
Français Tel: (+49) 0-180-532 93 58
Italiano Tel: (+49) 0-180-534 16 80

National Semiconductor Hong Kong Ltd.
19th Floor, Straight Block,
Ocean Centre, 5 Canton Rd.
Tsimshatsui, Kowloon
Hong Kong
Tel: (852) 2737-1600
Fax: (852) 2736-9960

National Semiconductor Japan Ltd.
Tel: 81-043-299-2309
Fax: 81-043-299-2408

National does not assume any responsibility for use of any circuitry described, no circuit patent licenses are implied and National reserves the right at any time without notice to change said circuitry and specifications.

National Semiconductor was acquired by Texas Instruments.

http://www.ti.com/corp/docs/investor_relations/pr_09_23_2011_national_semiconductor.html

This file is the datasheet for the following electronic components:

AH5020C - <http://www.ti.com/product/ah5020c?HQS=TI-null-null-dscatalog-df-pf-null-ww>



LittleDiode supplies new, hard to find or obsolete electronic components and semiconductors all over the world.

With over two million different components listed you are sure to find the part you need.

Feel free to visit us today at our online store:

LittleDiode.com

Looking forward to providing you with the best possible service.