

March 1997

### Features

- **Low Operating Current**  
-  $V_{DD} = 5V$ , Cycle Time  $1\mu s$  ..... **8mA**
- **Industry Standard Pinout**
- **Two Chip-Select Inputs-Simple Memory Expansion**
- **Memory Retention for Standby Battery Voltage of 2V Minimum**
- **Output-Disable for Common I/O Systems**
- **Three-State Data Output for Bus-Oriented Systems**
- **Separate Data Inputs and Outputs**

### Ordering Information

5V	10V	PACKAGE	TEMP. RANGE	PKG. NO.
CDP1822CE	CDP1822E	PDIP	-40°C to +85°C	E22.4
CDP1822CEX	CDP1822EX	Burn-In		E22.4
CDP1822CD	CDP1822D	SBDIP	-40°C to +85°C	D22.4A
CDP1822CDX	-	Burn-In		D22.4A

### Description

The CDP1822 and CDP1822C are 256-word by 4-bit static random-access memories designed for use in memory systems where high speed, low operating current, and simplicity in use are desirable. The CDP1822 features high speed and a wide operating voltage range. Both types have separate data inputs and outputs and utilize single power supplies of 4V to 6.5V for the CDP1822C and 4V to 10.5V for the CDP1822.

Two Chip-Select inputs are provided to simplify system expansion. An Output Disable control provides Wire-OR capability and is also useful in common Input/Output systems. The Output Disable input allows these RAMs to be used in common data Input/Output systems by forcing the output into a high-impedance state during a write operation independent of the Chip-Select input condition. The output assumes a high-impedance state when the Output Disable is at high level or when the chip is deselected by  $\overline{CS1}$  and/or  $\overline{CS2}$ .

The high noise immunity of the CMOS technology is preserved in this design. For TTL interfacing at 5V operation, excellent system noise margin is preserved by using an external pull-up resistor at each input.

### Pinout

CDP1822, CDP1822C  
(PDIP, SBDIP)  
TOP VIEW

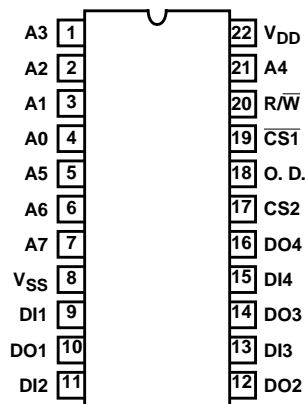

OPERATIONAL MODES

MODE	INPUTS				OUTPUT
	CHIP SELECT 1 ( $\overline{CS1}$ )	CHIP SELECT 2 ( $\overline{CS2}$ )	OUTPUT DISABLE (OD)	READ/WRITE (R/W)	
Read	0	1	0	1	Read
Write	0	1	0	0	Data In
Write	0	1	1	0	High Impedance
Standby	1	X	X	X	High Impedance
Standby	X	0	X	X	High Impedance
Output Disable	X	X	1	X	High Impedance

NOTE:

Logic 1 = High, Logic 0 = Low, X = Don't Care.

## CDP1822, CDP1822C

### Absolute Maximum Ratings

DC Supply Voltage Range, ( $V_{DD}$ ) (All Voltages Referenced to $V_{SS}$ Terminal)	
CDP1822	-0.5V to +11V
CDP1822C	-0.5V to +7V
Input Voltage Range, All Inputs	-0.5V to $V_{DD} + 0.5V$
DC Input Current, Any One Input	$\pm 10mA$

### Thermal Information

Thermal Resistance (Typical)	$\theta_{JA}$ ( $^{\circ}C/W$ )	$\theta_{JC}$ ( $^{\circ}C/W$ )
PDIP Package	75	N/A
SBDIP Package	80	21
Maximum Operating Temperature Range ( $T_A$ )		
Package Type D	-55 $^{\circ}C$ to +125 $^{\circ}C$	
Package Type E	-40 $^{\circ}C$ to +85 $^{\circ}C$	
Maximum Junction Temperature		
Ceramic Package	175 $^{\circ}C$	
Plastic Package	150 $^{\circ}C$	
Storage Temperature Range ( $T_{STG}$ )	-65 $^{\circ}C$ to +150 $^{\circ}C$	
$T_A = -40^{\circ}C$ to +60 $^{\circ}C$ (Package Type E)	500mW	
$T_A = +60^{\circ}C$ to +85 $^{\circ}C$ (Package Type E)	Derate Linearly at 12mW/ $^{\circ}C$ to 200mW	
Lead Temperature (During Soldering)	300 $^{\circ}C$	

**Recommended Operating Conditions** At  $T_A$  = Full Package Temperature Range. For maximum reliability, operating conditions should be selected so that operation is always within the following ranges:

PARAMETER	SYMBOL	LIMITS				UNITS
		CDP1822		CDP1822C		
		MIN	MAX	MIN	MAX	
DC Operating Voltage Range		4	10.5	4	6.5	V
Input Voltage Range		$V_{SS}$	$V_{DD}$	$V_{SS}$	$V_{DD}$	V

**Static Electrical Specifications** At  $T_A = -40^{\circ}C$  to +85 $^{\circ}C$ , Except as Noted

PARAMETER	SYMBOL	CONDITIONS			LIMITS						UNITS
		$V_O$ (V)	$V_{IN}$ (V)	$V_{DD}$ (V)	CDP1822			CDP1822C			
					MIN	(NOTE 1) TYP	MAX	MIN	(NOTE 1) TYP	MAX	
Quiescent Device Current	$I_{DD}$	-	0, 5	5	-	-	500	-	-	500	$\mu A$
		-	0, 10	10	-	-	1000	-	-	-	$\mu A$
Output Low (Sink) Current	$I_{OL}$	0.4	0, 5	5	2	4	-	2	4	-	mA
		0.5	0, 10	10	4.5	9	-	-	-	-	mA
Output High (Source) Current	$I_{OH}$	4.6	0, 5	5	-1	-2	-	-1	-2	-	mA
		9.5	0, 10	10	-2.2	-4.4	-	-	-	-	mA
Output Voltage Low-Level	$V_{OL}$	-	0, 5	5	-	0	0.1	-	0	0.1	V
		-	0, 10	10	-	0	0.1	-	-	-	V
Output Voltage High-Level	$V_{OH}$	-	0, 5	5	4.9	5	-	4.9	5	-	V
		-	0, 10	10	9.9	10	-	-	-	-	V
Input Low Voltage	$V_{IL}$	0.5, 4.5	-	5	-	-	1.5	-	-	1.5	V
		0.5, 9.5	-	10	-	-	3	-	-	-	V
Input High Voltage	$V_{IH}$	0.5, 9.5	-	5	3.5	-	-	3.5	-	-	V
		0.5, 9.5	-	10	7	-	-	-	-	-	V
Input Leakage Current	$I_{IN}$	-	0, 5	5	-	-	$\pm 5$	-	-	$\pm 5$	$\mu A$
		-	0, 10	10	-	-	$\pm 10$	-	-	-	$\mu A$

## CDP1822, CDP1822C

### Static Electrical Specifications At $T_A = -40^{\circ}\text{C}$ to $+85^{\circ}\text{C}$ , Except as Noted (Continued)

PARAMETER	SYMBOL	CONDITIONS			LIMITS						UNITS
		$V_O$ (V)	$V_{IN}$ (V)	$V_{DD}$ (V)	CDP1822			CDP1822C			
					MIN	(NOTE 1) TYP	MAX	MIN	(NOTE 1) TYP	MAX	
Operating Current (Note 2)	$I_{DD1}$	-	0, 5	5	-	4	8	-	4	8	mA
		-	0, 10	10	-	8	16	-	-	-	mA
Three-State Output Leakage Current	$I_{OUT}$	0, 5	0, 5	5	-	-	$\pm 5$	-	-	$\pm 5$	$\mu\text{A}$
		0, 10	0, 10	10	-	-	$\pm 10$	-	-	-	$\mu\text{A}$
Input Capacitance	$C_{IN}$	-	-	-	-	5	7.5	-	5	7.5	pF
Output Capacitance	$C_{OUT}$	-	-	-	-	10	15	-	10	15	pF

**NOTES:**

1. Typical values are for  $T_A = +25^{\circ}\text{C}$  and nominal  $V_{DD}$ .
2. Outputs open circuited; Cycle time =  $1\mu\text{s}$ .

### Dynamic Electrical Specifications At $T_A = -40$ to $+85^{\circ}\text{C}$ , $V_{DD} \pm 5\%$ , Input $t_R, t_F = 20\text{ns}$ , $V_{IH} = 0.7 V_{DD}$ , $V_{IL} = 0.3 V_{DD}$ , $C_L = 100\text{pF}$

PARAMETER	TEST CONDITIONS	LIMITS						UNITS	
		$V_{DD}$ (V)	CD1822			CDP1822C			
			(NOTE 1) MIN	(NOTE 2) TYP	MAX	(NOTE 1) MIN	(NOTE 2) TYP		MAX
Read Cycle Times (Figure 1)									
Read Cycle	$t_{RC}$	5	450	-	-	450	-	-	ns
		10	250	-	-	-	-	-	ns
Access from Address	$t_{AA}$	5	-	250	450	-	250	450	ns
		10	-	150	250	-	-	-	ns
Output Valid from $\overline{\text{Chip-Select 1}}$	$t_{DOA1}$	5	-	250	450	-	250	450	ns
		10	-	150	250	-	-	-	ns
Output Valid from Chip-Select 2	$t_{DOA2}$	5	-	250	450	-	250	450	ns
		10	-	150	250	-	-	-	ns
Output Valid from Output Disable	$t_{DOA3}$	5	-	-	200	-	-	200	ns
		10	-	-	110	-	-	-	ns
Output Hold from $\overline{\text{Chip-Select 1}}$	$t_{DOH1}$	5	20	-	-	20	-	-	ns
		10	20	-	-	-	-	-	ns
Output Hold from Chip-Select 2	$t_{DOH2}$	5	20	-	-	20	-	-	ns
		10	20	-	-	-	-	-	ns
Output Hold from Output Disable	$t_{DOH3}$	5	20	-	-	20	-	-	ns
		10	20	-	-	-	-	-	ns

**NOTES:**

1. Time required by a limit device to allow for indicated function.
2. Typical values are for  $T_A = 25^{\circ}\text{C}$  and nominal  $V_{DD}$ .

## CDP1822, CDP1822C

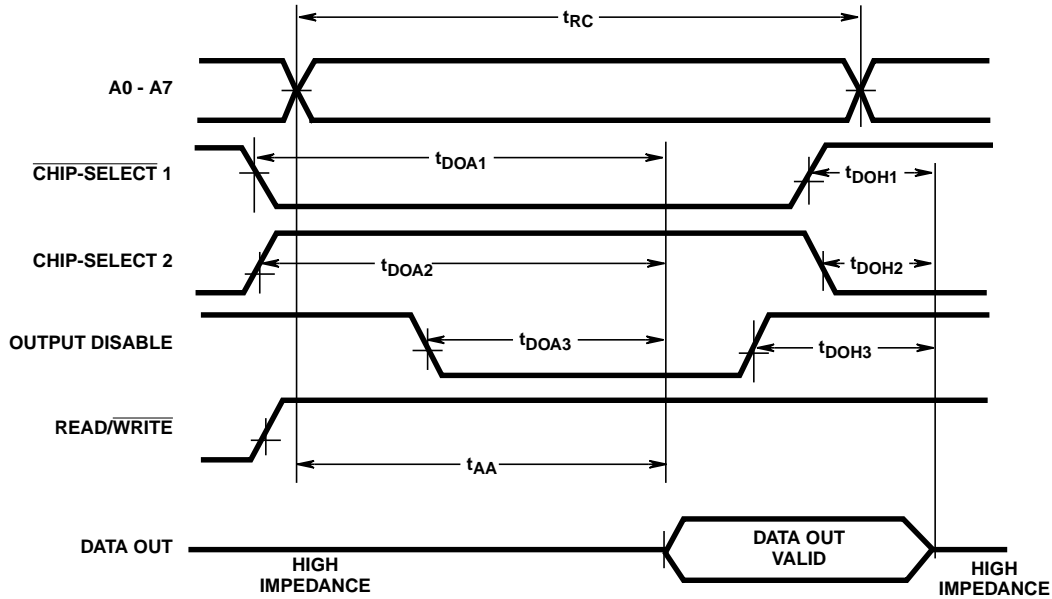

**FIGURE 1. READ CYCLE TIMING WAVEFORMS**

**Dynamic Electrical Specifications** At  $T_A + -40$  to  $+85^\circ\text{C}$ ,  $V_{DD} \pm 5\%$ , Input  $t_R$ ,  $t_F = 20\text{ns}$ ,  $V_{IH} = 0.7 V_{DD}$ ,  $V_{IL} = 0.3 V_{DD}$ ,  $C_L = 100 \text{pF}$ .

PARAMETER	TEST CONDITIONS	LIMITS						UNITS	
		CD1822			CDP1822C				
		(NOTE 1) MIN	(NOTE 2) TYP	MAX	(NOTE 1) MIN	(NOTE 2) TYP	MAX		
Read Cycle Times (Figure 2)									
Write Cycle	$t_{WC}$	5	500	-	-	500	-	-	ns
		10	300	-	-	-	-	-	ns
Address Setup	$t_{AS}$	5	200	-	-	200	-	-	ns
		10	110	-	-	-	-	-	ns
Write Recovery	$t_{WR}$	5	50	-	-	50	-	-	ns
		10	40	-	-	-	-	-	ns
Write Width	$t_{WRW}$	5	250	-	-	250	-	-	ns
		10	150	-	-	-	-	-	ns
Input Data Setup Time	$t_{DS}$	5	250	-	-	250	-	-	ns
		10	150	-	-	-	-	-	ns
Data Hold	$t_{DH}$	5	50	-	-	50	-	-	ns
		10	40	-	-	-	-	-	ns
Chip-Select 1 Setup	$t_{CS1S}$	5	200	-	-	200	-	-	ns
		10	110	-	-	-	-	-	ns
Chip-Select 2 Setup	$t_{CS2S}$	5	200	-	-	200	-	-	ns
		10	110	-	-	-	-	-	ns

## CDP1822, CDP1822C

**Dynamic Electrical Specifications** At  $T_A = -40$  to  $+85^\circ\text{C}$ ,  $V_{DD} \pm 5\%$ , Input  $t_R, t_F = 20\text{ns}$ ,  $V_{IH} = 0.7 V_{DD}$ ,  $V_{IL} = 0.3 V_{DD}$ ,  $C_L = 100\text{pF}$ . (Continued)

PARAMETER	TEST CONDITIONS	LIMITS						UNITS
		CD1822			CDP1822C			
		(NOTE 1) MIN	(NOTE 2) TYP	MAX	(NOTE 1) MIN	(NOTE 2) TYP	MAX	
Chip-Select 1 Hold $t_{CS1H}$	5	0	-	-	0	-	-	ns
	10	0	-	-	0	-	-	ns
Chip-Select 2 Hold $t_{CS2H}$	5	0	-	-	0	-	-	ns
	10	0	-	-	0	-	-	ns
Output Disable Set-Up $t_{ODS}$	5	200	-	-	200	-	-	ns
	10	110	-	-	-	-	-	ns

**NOTES:**

1. Time required by a limit device to allow for indicated function.
2. Typical values are for  $T_A = 25^\circ\text{C}$  and nominal  $V_{DD}$ .

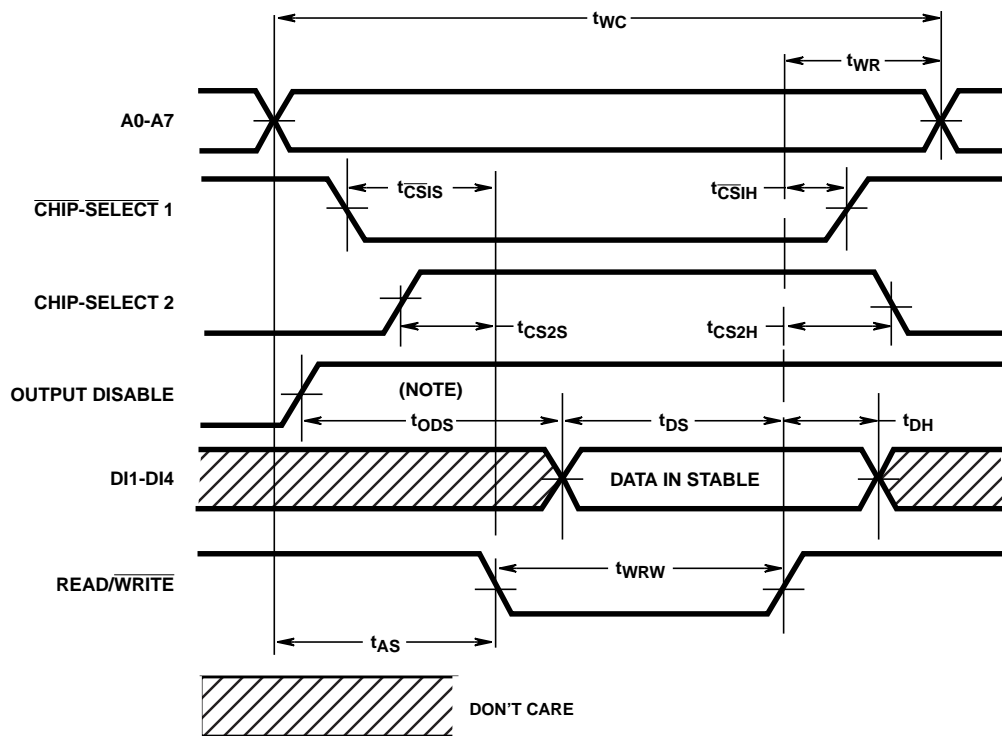

NOTE:  $t_{ODS}$  is required for common I/O operation only. For separate I/O operations, output disable is don't care.

**FIGURE 2. WRITE CYCLE TIME WAVEFORMS**

# CDP1822, CDP1822C

## Data Retention Specifications At $T_A = -40$ to $+85^\circ\text{C}$ , see Figure 3.

PARAMETER		TEST CONDITIONS		LIMITS						UNITS
		$V_{DR}$ (V)	$V_{DD}$ (V)	CDP1822			CDP1822C			
				MIN	(NOTE 1) TYP	MAX	MIN	(NOTE 1) TYP	MAX	
Min. Data Retention Voltage	$V_{DR}$	-	-	-	1.5	2	-	1.5	2	V
Data Retention Quiescent Current	$I_{DD}$	2	-	-	30	100	-	30	100	$\mu\text{A}$
Chip Deselect to Data Retention Time	$t_{CDR}$	-	5	600	-	-	600	-	-	ns
		-	10	300	-	-	-	-	-	ns
Recovery to Normal Operation Time	$t_{RC}$	-	5	600	-	-	600	-	-	ns
		-	10	300	-	-	-	-	-	ns
$V_{DD}$ to $V_{DR}$ Rise and Fall Time	$t_r, t_f$	2	5	1	-	-	1	-	-	$\mu\text{A}$

NOTE: Typical values are for  $T_A = 25^\circ\text{C}$  and nominal  $V_{DD}$ .

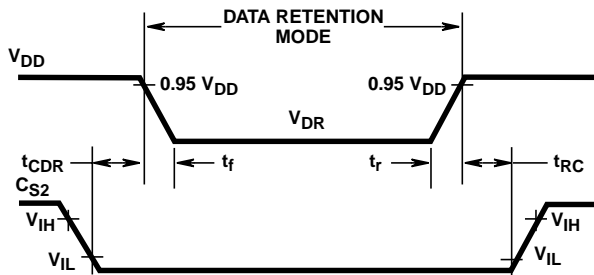

FIGURE 3. LOW  $V_{DD}$  DATA RETENTION TIME WAVEFORMS

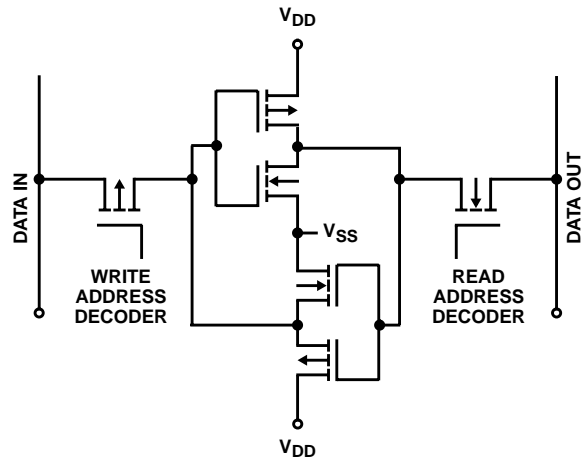

FIGURE 4. MEMORY CELL CONFIGURATION

CDP1822, CDP1822C

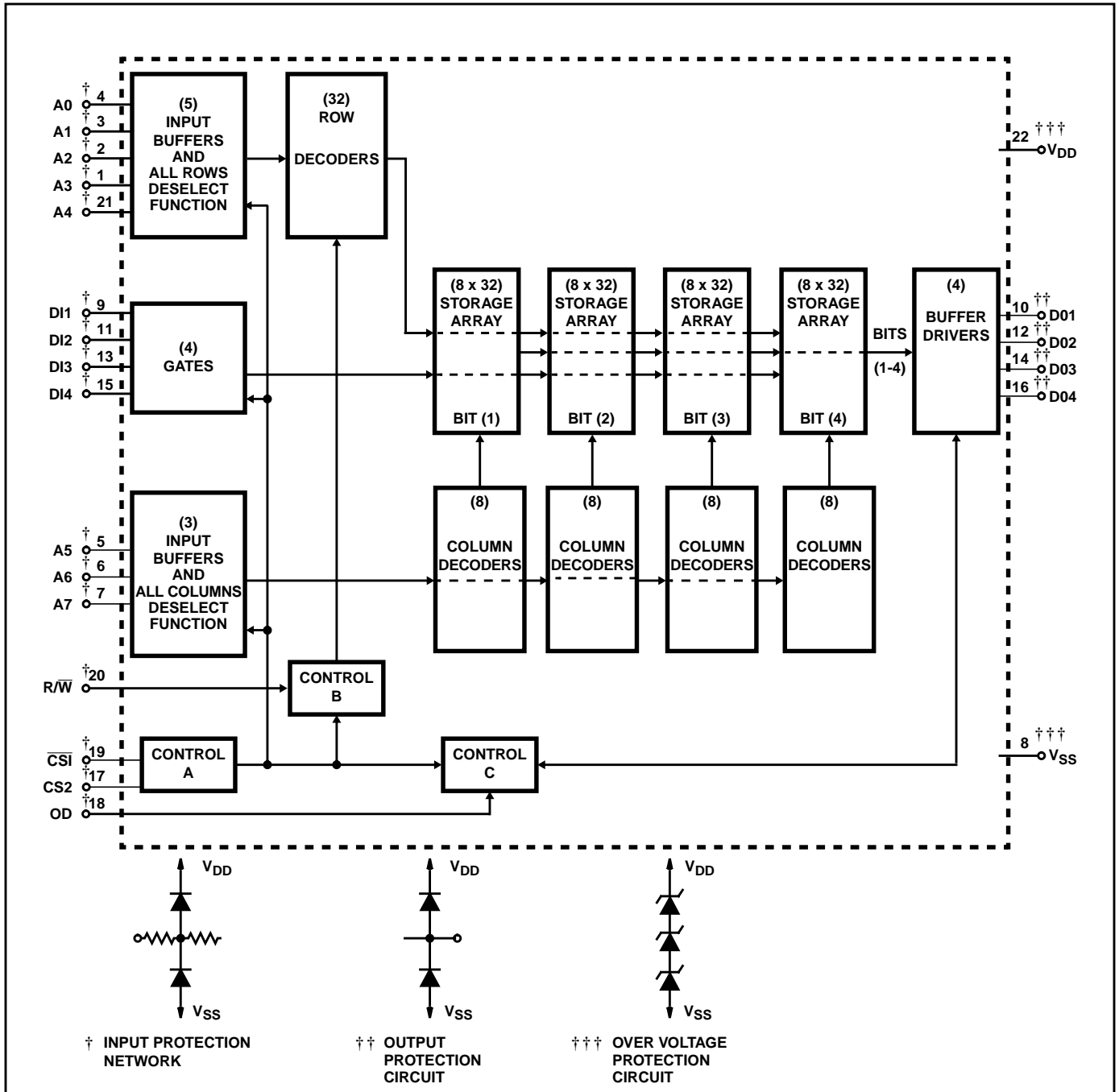
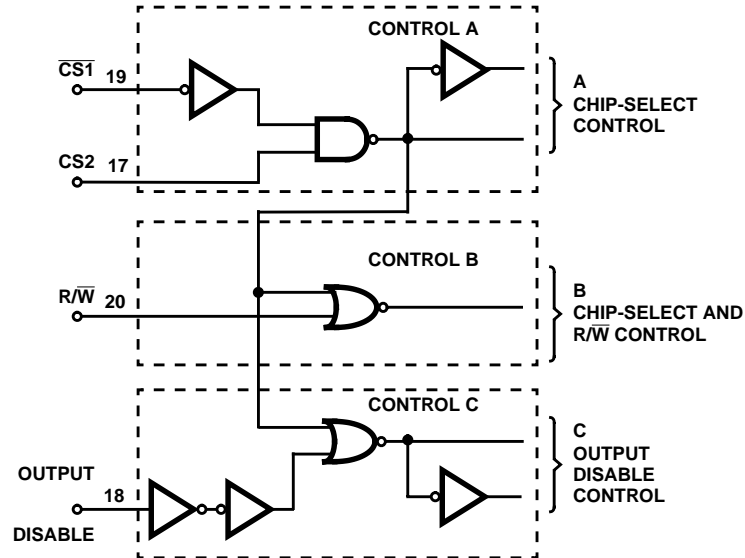

FIGURE 5. FUNCTIONAL BLOCK DIAGRAM FOR CDP1822 AND CDP1822C

## CDP1822, CDP1822CS



**FIGURE 6. LOGIC DIAGRAM OF CONTROLS FOR CDP1822 AND CDP1822C**

All Intersil semiconductor products are manufactured, assembled and tested under **ISO9000** quality systems certification.

*Intersil products are sold by description only. Intersil Corporation reserves the right to make changes in circuit design and/or specifications at any time without notice. Accordingly, the reader is cautioned to verify that data sheets are current before placing orders. Information furnished by Intersil is believed to be accurate and reliable. However, no responsibility is assumed by Intersil or its subsidiaries for its use; nor for any infringements of patents or other rights of third parties which may result from its use. No license is granted by implication or otherwise under any patent or patent rights of Intersil or its subsidiaries.*

For information regarding Intersil Corporation and its products, see web site <http://www.intersil.com>

### **Sales Office Headquarters**

#### **NORTH AMERICA**

Intersil Corporation  
P. O. Box 883, Mail Stop 53-204  
Melbourne, FL 32902  
TEL: (407) 724-7000  
FAX: (407) 724-7240

#### **EUROPE**

Intersil SA  
Mercure Center  
100, Rue de la Fusée  
1130 Brussels, Belgium  
TEL: (32) 2.724.2111  
FAX: (32) 2.724.22.05

#### **ASIA**

Intersil (Taiwan) Ltd.  
Taiwan Limited  
7F-6, No. 101 Fu Hsing North Road  
Taipei, Taiwan  
Republic of China  
TEL: (886) 2 2716 9310  
FAX: (886) 2 2715 3029

This datasheet has been downloaded from:

[www.DatasheetCatalog.com](http://www.DatasheetCatalog.com)

Datasheets for electronic components.



LittleDiode supplies new, hard to find or obsolete electronic components and semiconductors all over the world.

With over two million different components listed you are sure to find the part you need.

Feel free to visit us today at our online store:

[LittleDiode.com](http://LittleDiode.com)

Looking forward to providing you with the best possible service.