

# 74LV4066

## Quad bilateral switches

Rev. 03 — 4 July 2005

Product data sheet

## 1. General description

---

The 74LV4066 is a low-voltage Si-gate CMOS device that is pin and function compatible with the 74HC4066 and 74HCT4066.

The 74LV4066 has four independent switches. Each switch has two input/output pins (nY, nZ) and an active HIGH enable input pin (nE). When nE is LOW the corresponding analog switch is turned off.

The 74LV4066 has a ON-resistance which is reduced in comparison with the 74HCT4066.

## 2. Features

---

- Optimized for low-voltage applications: 1.0 V to 3.6 V
- Typical  $V_{OLP}$  (output ground bounce): < 0.8 V at  $V_{CC} = 3.3$  V and  $T_{amb} = 25$  °C
- Accepts TTL input levels between  $V_{CC} = 2.7$  V and  $V_{CC} = 3.6$  V
- Very low ON-resistance:
  - ◆ 60  $\Omega$  (typical) at  $V_{CC} = 2.0$  V
  - ◆ 35  $\Omega$  (typical) at  $V_{CC} = 3.0$  V
  - ◆ 25  $\Omega$  (typical) at  $V_{CC} = 4.5$  V
- ESD protection:
  - ◆ HBM EIA/JESD22-A114C exceeds 2000 V
  - ◆ MM EIA/JESD22-A115-A exceeds 200 V
- Specified from  $-40$  °C to  $+80$  °C and from  $-40$  °C to  $+125$  °C

**PHILIPS**

### 3. Quick reference data

**Table 1: Quick reference data**

$GND = 0\text{ V}$ ;  $T_{amb} = 25\text{ °C}$ ;  $t_r = t_f \leq 2.5\text{ ns}$ ;  $C_L = 15\text{ pF}$ ;  $R_L = 1\text{ k}\Omega$ .

Symbol	Parameter	Conditions	Min	Typ	Max	Unit
$t_{PZL}$ , $t_{PZH}$	turn-on time nE to $V_{OS}$	$V_{CC} = 3.3\text{ V}$	-	10	-	ns
$t_{PLZ}$ , $t_{PHZ}$	turn-off time nE to $V_{OS}$	$V_{CC} = 3.3\text{ V}$	-	13	-	ns
$C_i$	input capacitance		-	3.5	-	pF
$C_S$	maximum switch capacitance		-	8	-	pF
$C_{PD}$	power dissipation capacitance per switch	$V_{CC} = 3.3\text{ V}$	[1][2]	11	-	pF

[1]  $C_{PD}$  is used to determine the dynamic power dissipation ( $P_D$  in  $\mu\text{W}$ ).

$P_D = C_{PD} \times V_{CC}^2 \times f_i \times N + \Sigma[(C_L + C_S) \times V_{CC}^2 \times f_o]$  where:

$f_i$  = input frequency in MHz;

$f_o$  = output frequency in MHz;

$C_L$  = output load capacitance in pF;

$C_S$  = maximum switch capacitance in pF;

$V_{CC}$  = supply voltage in V;

$N$  = number of inputs switching;

$\Sigma[(C_L + C_S) \times V_{CC}^2 \times f_o]$  = sum of the outputs.

[2] The condition is  $V_i = GND$  to  $V_{CC}$ .

### 4. Ordering information

**Table 2: Ordering information**

Type number	Package			Version
	Temperature range	Name	Description	
74LV4066N	-40 °C to +125 °C	DIP14	plastic dual in-line package; 14 leads (300 mil)	SOT27-1
74LV4066D	-40 °C to +125 °C	SO14	plastic small outline package; 14 leads; body width 3.9 mm	SOT108-1
74LV4066DB	-40 °C to +125 °C	SSOP14	plastic shrink small outline package; 14 leads; body width 5.3 mm	SOT337-1
74LV4066PW	-40 °C to +125 °C	TSSOP14	plastic thin shrink small outline package; 14 leads; body width 4.4 mm	SOT402-1

5. Functional diagram

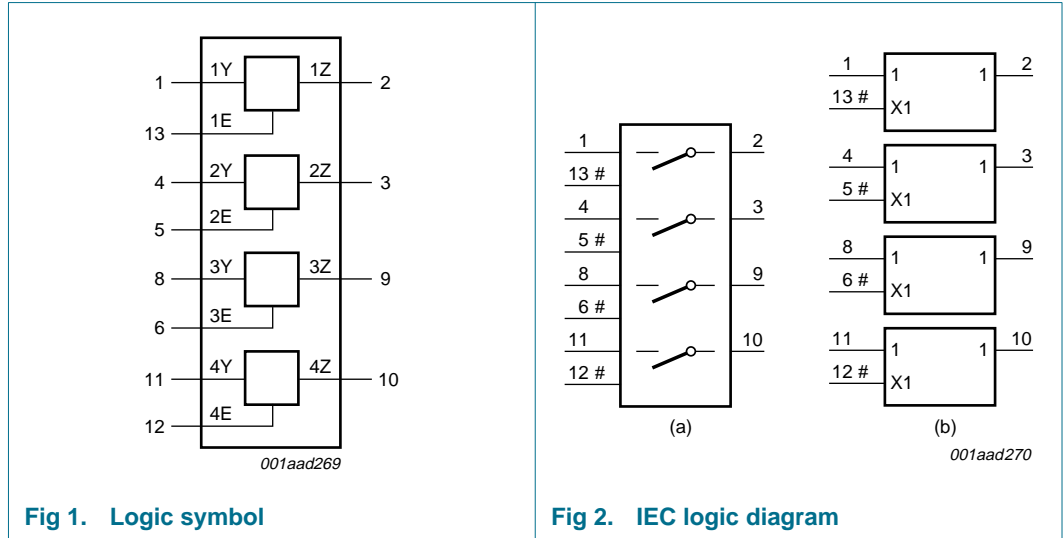

Fig 1. Logic symbol

Fig 2. IEC logic diagram

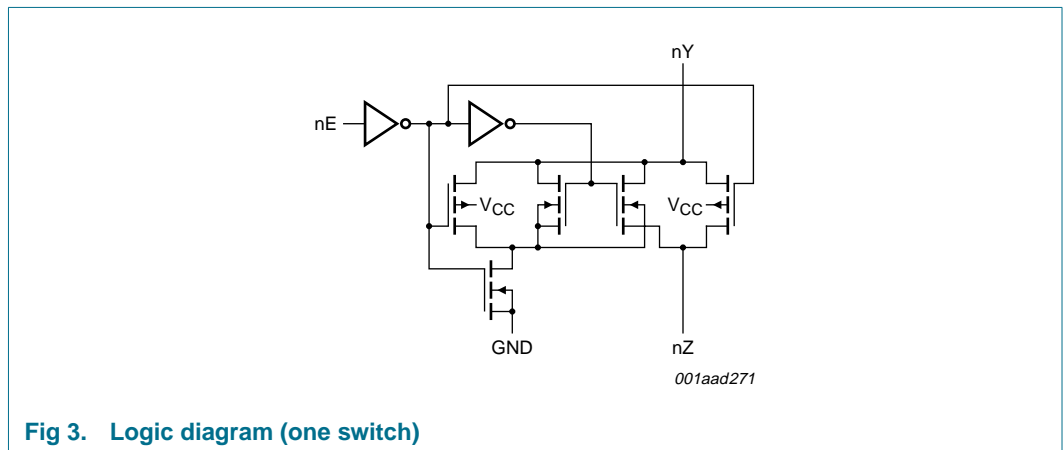
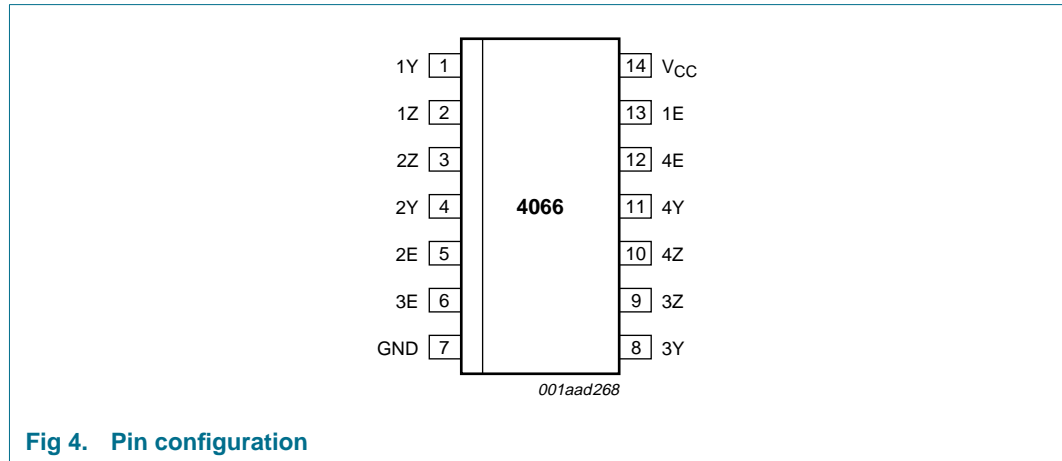

Fig 3. Logic diagram (one switch)

## 6. Pinning information

### 6.1 Pinning



### 6.2 Pin description

Table 3: Pin description

Symbol	Pin	Description
1Y	1	independent input or output
1Z	2	independent output or input
2Z	3	independent output or input
2Y	4	independent input or output
2E	5	enable input
3E	6	enable input
GND	7	ground (0 V)
3Y	8	independent input or output
3Z	9	independent output or input
4Z	10	independent output or input
4Y	11	independent input or output
4E	12	enable input
1E	13	enable input
V <sub>CC</sub>	14	supply voltage

## 7. Functional description

### 7.1 Function table

Table 4: Function table

Input nE	Switch
LOW	off
HIGH	on

## 8. Limiting values

**Table 5: Limiting values**

In accordance with the Absolute Maximum Rating System (IEC 60134). Voltages are referenced to GND (ground = 0 V).

Symbol	Parameter	Conditions	Min	Max	Unit
$V_{CC}$	supply voltage		-0.5	+7.0	V
$I_{IK}$	input diode current	$V_I < -0.5\text{ V}$ or $V_I > V_{CC} + 0.5\text{ V}$	-	$\pm 20$	mA
$I_{OK}$	output diode current	$V_O < -0.5\text{ V}$ or $V_O > V_{CC} + 0.5\text{ V}$	-	$\pm 50$	mA
$I_S$	switch source or sink current	$V_O = -0.5\text{ V}$ to $(V_{CC} + 0.5\text{ V})$	[1] -	$\pm 25$	mA
$T_{stg}$	storage temperature		-65	+150	°C
$P_{tot}$	total power dissipation	$T_{amb} = -40\text{ °C}$ to $+125\text{ °C}$			
	DIP14 package		[2] -	750	mW
	SO14 package		[3] -	500	mW
	(T)SSOP14 package		[4]	400	mW

[1] The input and output voltage ratings may be exceeded if the input and output current ratings are observed.

[2] DIP14 package:  $P_{tot}$  derates linearly with 12 mW/K above 70 °C.

[3] SO14 package:  $P_{tot}$  derates linearly with 8 mW/K above 70 °C.

[4] (T)SSOP14 package:  $P_{tot}$  derates linearly with 5.5 mW/K above 60 °C.

## 9. Recommended operating conditions

**Table 6: Recommended operating conditions**

Symbol	Parameter	Conditions	Min	Typ	Max	Unit
$V_{CC}$	supply voltage		[1] 1.0	3.3	6	V
$V_I$	input voltage		0	-	$V_{CC}$	V
$V_O$	output voltage		0	-	$V_{CC}$	V
$T_{amb}$	ambient temperature	in free air	-40	-	+125	°C
$t_r, t_f$	input rise and fall times	$V_{CC} = 1.0\text{ V}$ to $2.0\text{ V}$	-	-	500	ns/V
		$V_{CC} = 2.0\text{ V}$ to $2.7\text{ V}$	-	-	200	ns/V
		$V_{CC} = 2.7\text{ V}$ to $3.6\text{ V}$	-	-	100	ns/V
		$V_{CC} = 3.6\text{ V}$ to $5.5\text{ V}$	-	-	50	ns/V

[1] The static characteristics are guaranteed from  $V_{CC} = 1.2\text{ V}$  to  $V_{CC} = 5.5\text{ V}$ , but LV devices are guaranteed to function down to  $V_{CC} = 1.0\text{ V}$  (with input levels GND or  $V_{CC}$ ).

## 10. Static characteristics

**Table 7: Static characteristics**

At recommended operating conditions; voltages are referenced to GND (ground = 0 V).

Symbol	Parameter	Conditions	Min	Typ	Max	Unit
<b><math>T_{amb} = -40\text{ °C to }+85\text{ °C}</math></b>						
$V_{IH}$	HIGH-level input voltage	$V_{CC} = 1.2\text{ V}$	0.90	-	-	V
		$V_{CC} = 2.0\text{ V}$	1.40	-	-	V
		$V_{CC} = 2.7\text{ V to }3.6\text{ V}$	2.00	-	-	V
		$V_{CC} = 4.5\text{ V}$	3.15	-	-	V
		$V_{CC} = 6.0\text{ V}$	4.20	-	-	V
$V_{IL}$	LOW-level input voltage	$V_{CC} = 1.2\text{ V}$	-	-	0.30	V
		$V_{CC} = 2.0\text{ V}$	-	-	0.60	V
		$V_{CC} = 2.7\text{ V to }3.6\text{ V}$	-	-	0.80	V
		$V_{CC} = 4.5\text{ V}$	-	-	1.35	V
		$V_{CC} = 6.0\text{ V}$	-	-	1.80	V
$I_{LI}$	input leakage current	$V_I = V_{CC}$ or GND				
		$V_{CC} = 3.6\text{ V}$	-	-	1.0	$\mu\text{A}$
		$V_{CC} = 6.0\text{ V}$	-	-	2.0	$\mu\text{A}$
$I_{S(OFF)}$	analog switch OFF-state current	$V_I = V_{IH}$ or $V_{IL}$ ; see <a href="#">Figure 5</a>				
		$V_{CC} = 3.6\text{ V}$	-	-	1.0	$\mu\text{A}$
		$V_{CC} = 6.0\text{ V}$	-	-	2.0	$\mu\text{A}$
$I_{S(ON)}$	analog switch ON-state current	$V_I = V_{IH}$ or $V_{IL}$ ; see <a href="#">Figure 6</a>				
		$V_{CC} = 3.6\text{ V}$	-	-	1.0	$\mu\text{A}$
		$V_{CC} = 6.0\text{ V}$	-	-	2.0	$\mu\text{A}$
$I_{CC}$	supply current	$V_I = V_{CC}$ or GND; $I_O = 0\text{ A}$				
		$V_{CC} = 3.6\text{ V}$	-	-	20	$\mu\text{A}$
		$V_{CC} = 6.0\text{ V}$	-	-	40	$\mu\text{A}$
$\Delta I_{CC}$	additional supply current per input	$V_I = V_{CC} - 0.6\text{ V}$ ; $V_{CC} = 2.7\text{ V to }3.6\text{ V}$	-	-	500	$\mu\text{A}$
$C_i$	input capacitance		-	3.5	-	pF
<b><math>T_{amb} = -40\text{ °C to }+125\text{ °C}</math></b>						
$V_{IH}$	HIGH-level input voltage	$V_{CC} = 1.2\text{ V}$	0.90	-	-	V
		$V_{CC} = 2.0\text{ V}$	1.40	-	-	V
		$V_{CC} = 2.7\text{ V to }3.6\text{ V}$	2.00	-	-	V
		$V_{CC} = 4.5\text{ V}$	3.15	-	-	V
		$V_{CC} = 6.0\text{ V}$	4.20			V
$V_{IL}$	LOW-level input voltage	$V_{CC} = 1.2\text{ V}$	-	-	0.30	V
		$V_{CC} = 2.0\text{ V}$	-	-	0.60	V
		$V_{CC} = 2.7\text{ V to }3.6\text{ V}$	-	-	0.80	V
		$V_{CC} = 4.5\text{ V}$	-	-	1.35	V
		$V_{CC} = 6.0\text{ V}$	-	-	1.80	V

**Table 7: Static characteristics ...continued**

At recommended operating conditions; voltages are referenced to GND (ground = 0 V).

Symbol	Parameter	Conditions	Min	Typ	Max	Unit
$I_{LI}$	input leakage current	$V_I = V_{CC}$ or GND				
		$V_{CC} = 3.6$ V	-	-	1.0	$\mu$ A
		$V_{CC} = 6.0$ V	-	-	2.0	$\mu$ A
$I_{S(OFF)}$	analog switch OFF-state current	$V_I = V_{IH}$ or $V_{IL}$ ; see <a href="#">Figure 5</a>				
		$V_{CC} = 3.6$ V	-	-	1.0	$\mu$ A
		$V_{CC} = 6.0$ V	-	-	2.0	$\mu$ A
$I_{S(ON)}$	analog switch ON-state current	$V_I = V_{IH}$ or $V_{IL}$ ; see <a href="#">Figure 6</a>				
		$V_{CC} = 3.6$ V	-	-	1.0	$\mu$ A
		$V_{CC} = 6.0$ V	-	-	2.0	$\mu$ A
$I_{CC}$	supply current	$V_I = V_{CC}$ or GND; $I_O = 0$ A				
		$V_{CC} = 3.6$ V	-	-	40	$\mu$ A
		$V_{CC} = 6.0$ V	-	-	80	$\mu$ A
$\Delta I_{CC}$	additional supply current per input	$V_I = V_{CC} - 0.6$ V; $V_{CC} = 2.7$ V to 3.6 V	-	-	850	$\mu$ A

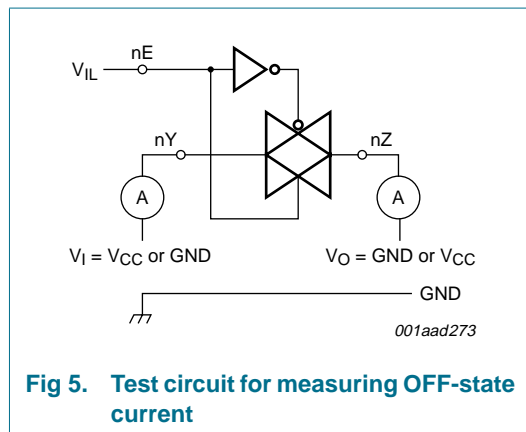

**Fig 5. Test circuit for measuring OFF-state current**

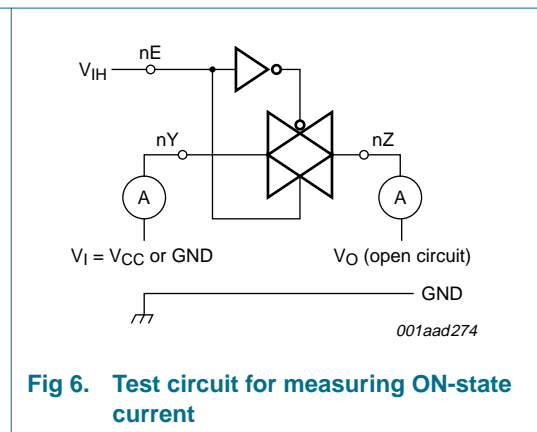

**Fig 6. Test circuit for measuring ON-state current**

**Table 8: ON-resistance**

At recommended operating conditions; voltages are referenced to GND (ground = 0 V); for test circuit see [Figure 7](#).

Symbol	Parameter	Conditions	Min	Typ	Max	Unit	
<b><math>T_{amb} = -40\text{ °C to }+85\text{ °C}</math> [1]; see <a href="#">Figure 8</a></b>							
$R_{ON(peak)}$	ON-resistance (peak)	$V_I = V_{IH}$ or $V_{IL}$					
		$V_{CC} = 1.2\text{ V}$	[2]	-	300	-	$\Omega$
		$V_{CC} = 2.0\text{ V}$	-	60	130	$\Omega$	
		$V_{CC} = 2.7\text{ V}$	-	41	60	$\Omega$	
		$V_{CC} = 3.0\text{ V to }3.6\text{ V}$	-	37	72	$\Omega$	
		$V_{CC} = 4.5\text{ V}$	-	25	52	$\Omega$	
		$V_{CC} = 6.0\text{ V}$	-	23	47	$\Omega$	
$R_{ON(rail)}$	ON-resistance (rail)	$V_I = V_{IH}$ or $V_{IL}$ ; $V_{is} = \text{GND}$					
		$V_{CC} = 1.2\text{ V}$	[2]	-	75	-	$\Omega$
		$V_{CC} = 2.0\text{ V}$	-	35	98	$\Omega$	
		$V_{CC} = 2.7\text{ V}$	-	26	60	$\Omega$	
		$V_{CC} = 3.0\text{ V to }3.6\text{ V}$	-	24	52	$\Omega$	
		$V_{CC} = 4.5\text{ V}$	-	15	40	$\Omega$	
		$V_{CC} = 6.0\text{ V}$	-	13	35	$\Omega$	
		$V_I = V_{IH}$ or $V_{IL}$ ; $V_{is} = V_{CC}$					
		$V_{CC} = 1.2\text{ V}$	[2]	-	75	-	$\Omega$
		$V_{CC} = 2.0\text{ V}$	-	40	110	$\Omega$	
		$V_{CC} = 2.7\text{ V}$	-	35	72	$\Omega$	
		$V_{CC} = 3.0\text{ V to }3.6\text{ V}$	-	30	65	$\Omega$	
		$V_{CC} = 4.5\text{ V}$	-	22	47	$\Omega$	
		$V_{CC} = 6.0\text{ V}$	-	20	40	$\Omega$	
$R_{ON(flatness)}$	ON-resistance (flatness)	$V_I = V_{IH}$ or $V_{IL}$ ; $V_{is} = V_{CC}$					
		$V_{CC} = 2.0\text{ V}$	-	5	-	$\Omega$	
		$V_{CC} = 2.7\text{ V}$	-	4	-	$\Omega$	
		$V_{CC} = 3.0\text{ V to }3.6\text{ V}$	-	4	-	$\Omega$	
		$V_{CC} = 4.5\text{ V}$	-	3	-	$\Omega$	
		$V_{CC} = 6.0\text{ V}$	-	2	-	$\Omega$	
<b><math>T_{amb} = -40\text{ °C to }+125\text{ °C}</math></b>							
$R_{ON(peak)}$	ON-resistance (peak)	$V_I = V_{IH}$ or $V_{IL}$					
		$V_{CC} = 2.0\text{ V}$	-	-	150	$\Omega$	
		$V_{CC} = 2.7\text{ V}$	-	-	90	$\Omega$	
		$V_{CC} = 3.0\text{ V to }3.6\text{ V}$	-	-	83	$\Omega$	
		$V_{CC} = 4.5\text{ V}$	-	-	60	$\Omega$	
		$V_{CC} = 6.0\text{ V}$	-	-	54	$\Omega$	

**Table 8: ON-resistance ...continued**

At recommended operating conditions; voltages are referenced to GND (ground = 0 V); for test circuit see [Figure 7](#).

Symbol	Parameter	Conditions	Min	Typ	Max	Unit	
$R_{ON(rail)}$	ON-resistance (rail)	$V_I = V_{IH}$ or $V_{IL}$ ; $V_{is} = GND$					
		$V_{CC} = 2.0\text{ V}$	-	-	115	$\Omega$	
		$V_{CC} = 2.7\text{ V}$	-	-	68	$\Omega$	
		$V_{CC} = 3.0\text{ V to }3.6\text{ V}$	-	-	60	$\Omega$	
		$V_{CC} = 4.5\text{ V}$	-	-	45	$\Omega$	
		$V_{CC} = 6.0\text{ V}$	-	-	40	$\Omega$	
		$V_I = V_{IH}$ or $V_{IL}$ ; $V_{is} = V_{CC}$					
		$V_{CC} = 2.0\text{ V}$	-	-	130	$\Omega$	
		$V_{CC} = 2.7\text{ V}$	-	-	85	$\Omega$	
		$V_{CC} = 3.0\text{ V to }3.6\text{ V}$	-	-	75	$\Omega$	
		$V_{CC} = 4.5\text{ V}$	-	-	55	$\Omega$	
		$V_{CC} = 6.0\text{ V}$	-	-	47	$\Omega$	

- [1] All typical values are measured at  $T_{amb} = 25\text{ }^\circ\text{C}$ .
- [2] At supply voltage approaching 1.2 V, the analog switch ON-resistance becomes extremely non-linear. Therefore it is recommended that these devices be used to transmit digital signals only, when using these supply voltages.

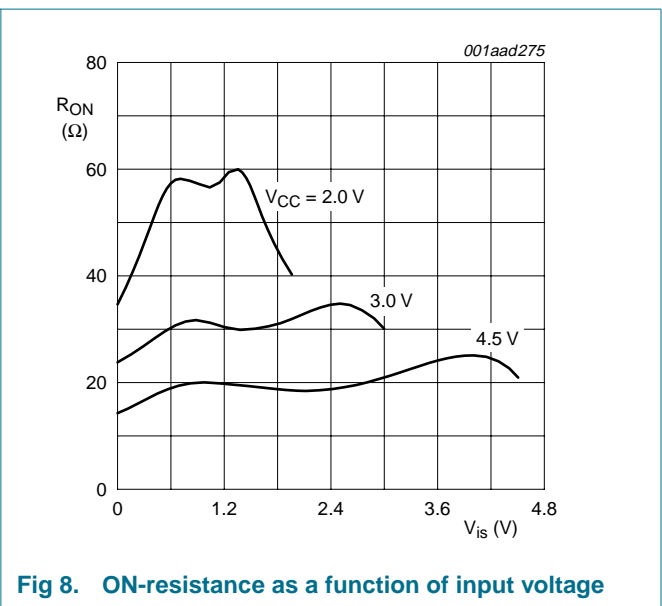
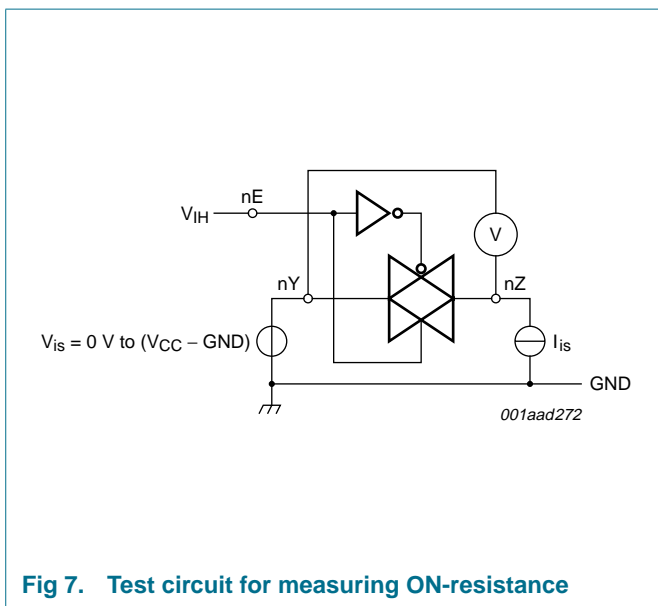

## 11. Dynamic characteristics

**Table 9: Dynamic characteristics**

Voltages are referenced to GND (ground = 0 V); for test circuit see [Figure 11](#).

Symbol	Parameter	Conditions	Min	Typ	Max	Unit	
<b><math>T_{amb} = -40\text{ °C to }+85\text{ °C}</math> [1]</b>							
$t_{PHL}$ , $t_{PLH}$	propagation delay $V_{is}$ to $V_{os}$	see <a href="#">Figure 9</a>					
		$V_{CC} = 1.2\text{ V}$	-	8	-	ns	
		$V_{CC} = 2.0\text{ V}$	-	5	26	ns	
		$V_{CC} = 2.7\text{ V to }3.6\text{ V}$	-	3	15	ns	
		$V_{CC} = 4.5\text{ V}$	-	2	13	ns	
		$V_{CC} = 6.0\text{ V}$	-	2	10	ns	
$t_{PZH}$ , $t_{PZL}$	turn-on time nE to $V_{os}$	see <a href="#">Figure 9</a>					
		$V_{CC} = 1.2\text{ V}$	-	40	-	ns	
		$V_{CC} = 2.0\text{ V}$	-	22	43	ns	
		$V_{CC} = 2.7\text{ V to }3.6\text{ V}$	-	12	25	ns	
		$V_{CC} = 3.3\text{ V}; C_L = 15\text{ pF}$	-	10	-	ns	
		$V_{CC} = 4.5\text{ V}$	-	10	21	ns	
		$V_{CC} = 6.0\text{ V}$	-	8	16	ns	
$t_{PHZ}$ , $t_{PLZ}$	turn-off time nE to $V_{os}$	see <a href="#">Figure 9</a>					
		$V_{CC} = 1.2\text{ V}$	-	50	-	ns	
		$V_{CC} = 2.0\text{ V}$	-	27	65	ns	
		$V_{CC} = 2.7\text{ V to }3.6\text{ V}$	-	15	38	ns	
		$V_{CC} = 3.3\text{ V}; C_L = 15\text{ pF}$	-	13	-	ns	
		$V_{CC} = 4.5\text{ V}$	-	13	32	ns	
		$V_{CC} = 6.0\text{ V}$	-	12	28	ns	
$C_{PD}$	power dissipation capacitance per switch	$V_{CC} = 3.3\text{ V}; C_L = 15\text{ pF}$	[2] [3]	-	11	-	pF
<b><math>T_{amb} = -40\text{ °C to }+125\text{ °C}</math></b>							
$t_{PHL}$ , $t_{PLH}$	propagation delay $V_{is}$ to $V_{os}$	see <a href="#">Figure 9</a>					
		$V_{CC} = 2.0\text{ V}$	-	-	31	ns	
		$V_{CC} = 2.7\text{ V to }3.6\text{ V}$	-	-	18	ns	
		$V_{CC} = 4.5\text{ V}$	-	-	15	ns	
		$V_{CC} = 6.0\text{ V}$	-	-	12	ns	
$t_{PZH}$ , $t_{PZL}$	turn-on time nE to $V_{os}$	see <a href="#">Figure 9</a>					
		$V_{CC} = 2.0\text{ V}$	-	-	51	ns	
		$V_{CC} = 2.7\text{ V to }3.6\text{ V}$	-	-	30	ns	
		$V_{CC} = 4.5\text{ V}$	-	-	26	ns	
		$V_{CC} = 6.0\text{ V}$	-	-	20	ns	

**Table 9: Dynamic characteristics ...continued**

Voltages are referenced to GND (ground = 0 V); for test circuit see [Figure 11](#).

Symbol	Parameter	Conditions	Min	Typ	Max	Unit
$t_{PHZ}$ , $t_{PLZ}$	turn-off time nE to $V_{OS}$	see <a href="#">Figure 9</a>				
		$V_{CC} = 2.0 \text{ V}$	-	-	81	ns
		$V_{CC} = 2.7 \text{ V to } 3.6 \text{ V}$	-	-	47	ns
		$V_{CC} = 4.5 \text{ V}$	-	-	40	ns
		$V_{CC} = 6.0 \text{ V}$	-	-	34	ns

[1] Typical values are measured at nominal  $V_{CC}$  and  $T_{amb} = 25 \text{ }^\circ\text{C}$ .

[2]  $C_{PD}$  is used to determine the dynamic power dissipation ( $P_D$  in  $\mu\text{W}$ ).

$$P_D = C_{PD} \times V_{CC}^2 \times f_i \times N + \Sigma[(C_L + C_S) \times V_{CC}^2 \times f_o] \text{ where:}$$

$f_i$  = input frequency in MHz;

$f_o$  = output frequency in MHz;

$C_L$  = output load capacitance in pF;

$C_S$  = maximum switch capacitance in pF;

$V_{CC}$  = supply voltage in V;

$N$  = number of inputs switching;

$\Sigma[(C_L + C_S) \times V_{CC}^2 \times f_o]$  = sum of the outputs.

[3] The condition is  $V_I = \text{GND to } V_{CC}$ .

12. Waveforms

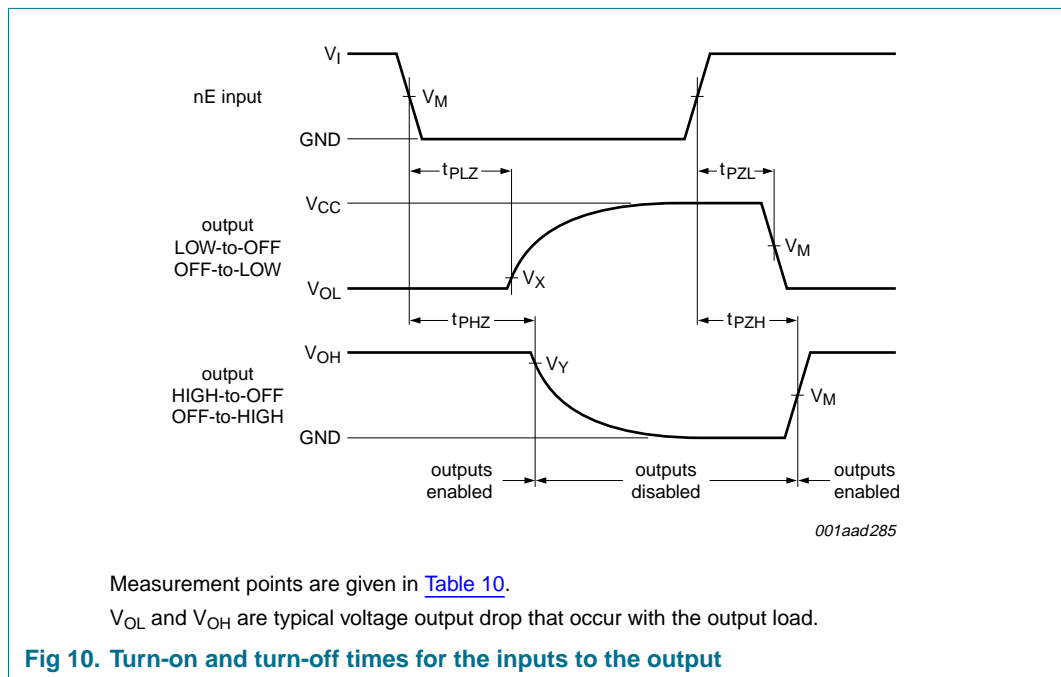
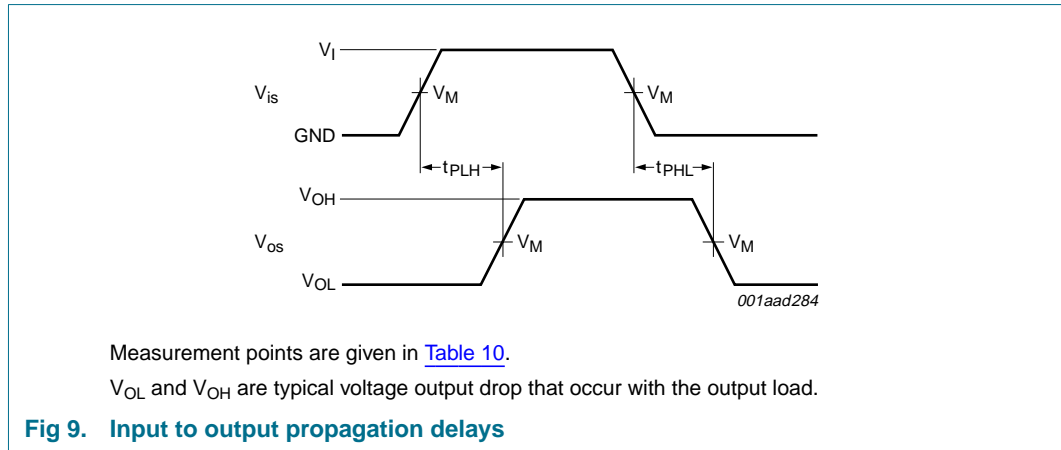
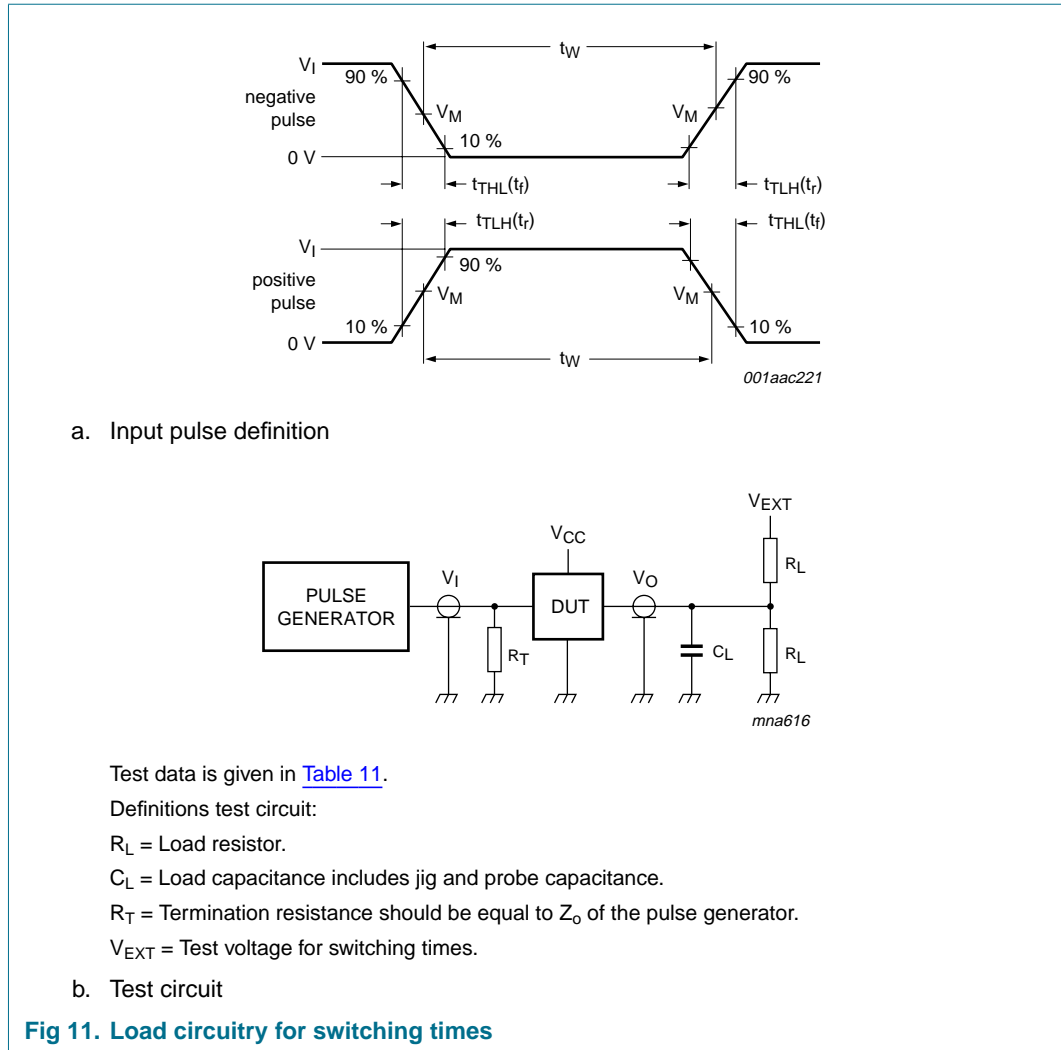

Table 10: Measurement points

Supply voltage	Input	Output		
$V_{CC}$	$V_M$	$V_M$	$V_X$	$V_Y$
$\geq 2.7\text{ V}$	1.5 V	1.5 V	$V_{OL} + 0.3$	$V_{OH} - 0.3\text{ V}$
$< 2.7\text{ V}$	$0.5 \times V_{CC}$	$0.5 \times V_{CC}$	$V_{OL} + 0.15$	$V_{OH} - 0.15\text{ V}$



**Table 11: Test data**

Supply voltage	Input		Load		$V_{EXT}$		
$V_{CC}$	$V_I$	$t_r, t_f$	$C_L$	$R_L$ [1]	$t_{PHZ}, t_{PZH}$	$t_{PLZ}, t_{PZL}$	$t_{PLH}, t_{PHL}$
< 2.7 V	$V_{CC}$	$\leq 2.5$ ns	50 pF	1 k $\Omega$	GND	$2 \times V_{CC}$	open
2.7 V to 3.6 V	2.7 V	$\leq 2.5$ ns	50 pF	1 k $\Omega$	GND	$2 \times V_{CC}$	open
$\geq 4.5$ V	$V_{CC}$	$\leq 2.5$ ns	50 pF	1 k $\Omega$	GND	$2 \times V_{CC}$	open

[1]  $R_L = \infty \Omega$  for measuring the propagation delays  $t_{PLH}$  and  $t_{PHL}$ .

### 13. Additional dynamic characteristics

**Table 12: Additional dynamic characteristics**

Voltages are referenced to GND (ground = 0 V);  $V_{is}$  is the input voltage at pin nY or nZ, whichever is assigned as an input;  $V_{os}$  is the output voltage at pin nY or nZ, whichever is assigned as an output.

Symbol	Parameter	Conditions	Min	Typ	Max	Unit		
$d_{sin}$	sine-wave distortion	$R_L = 10\text{ k}\Omega$ ; $f = 1\text{ kHz}$ ; $C_L = 50\text{ pF}$ ; see <a href="#">Figure 12</a>	$V_{CC} = 3.0\text{ V}$ ; $V_{is} = 2.75\text{ V (p-p)}$	-	0.04	-	%	
			$V_{CC} = 6.0\text{ V}$ ; $V_{is} = 5.50\text{ V (p-p)}$	-	0.02	-	%	
		$R_L = 10\text{ k}\Omega$ ; $f = 10\text{ kHz}$ ; $C_L = 50\text{ pF}$ ; see <a href="#">Figure 12</a>	$V_{CC} = 3.0\text{ V}$ ; $V_{is} = 2.75\text{ V (p-p)}$	-	0.12	-	%	
			$V_{CC} = 6.0\text{ V}$ ; $V_{is} = 5.50\text{ V (p-p)}$	-	0.06	-	%	
		$\alpha_{OFF(\text{feedthru})}$	switch OFF-state signal feed-through attenuation	$R_L = 600\text{ k}\Omega$ ; $f = 1\text{ MHz}$ ; $C_L = 50\text{ pF}$ ; see <a href="#">Figure 13</a> and <a href="#">Figure 14</a>		[1]		
					$V_{CC} = 3.0\text{ V}$	-	-50	-
$V_{CC} = 6.0\text{ V}$	-				-50	-	dB	
$\alpha_{ct(S)}$	crosstalk between switches	$R_L = 600\text{ k}\Omega$ ; $f = 1\text{ MHz}$ ; $C_L = 50\text{ pF}$ ; see <a href="#">Figure 15</a>		[1]				
			$V_{CC} = 3.0\text{ V}$	-	-60	-	dB	
			$V_{CC} = 6.0\text{ V}$	-	-60	-	dB	
$V_{ct(pp)}$	crosstalk voltage between enable input to any switch (peak-to-peak value)	$R_L = 600\text{ k}\Omega$ ; $f = 1\text{ MHz}$ ; $C_L = 50\text{ pF}$ ; see <a href="#">Figure 16</a> and <a href="#">Figure 17</a>		[2]				
			$V_{CC} = 3.0\text{ V}$	-	110	-	mV	
			$V_{CC} = 6.0\text{ V}$	-	220	-	mV	
$f_{max}$	minimum frequency response (-3 dB)	$R_L = 50\text{ k}\Omega$ ; $C_L = 50\text{ pF}$ ; see <a href="#">Figure 18</a> and <a href="#">Figure 19</a>		[3]				
			$V_{CC} = 3.0\text{ V}$	-	180	-	MHz	
			$V_{CC} = 6.0\text{ V}$	-	200	-	MHz	
$C_S$	maximum switch capacitance		-	8	-	pF		

[1] Adjust input voltage  $V_{is}$  is 0 dBm level (0 dBm = 1 mW into 600  $\Omega$ ).

[2] Pin nE: square wave between  $V_{CC}$  and GND,  $t_r = t_f = 6\text{ ns}$ .

[3] Adjust input voltage  $V_{is}$  is 0 dBm level at  $V_{os}$  for 1 MHz (0 dBm = 1 mW into 50  $\Omega$ ).

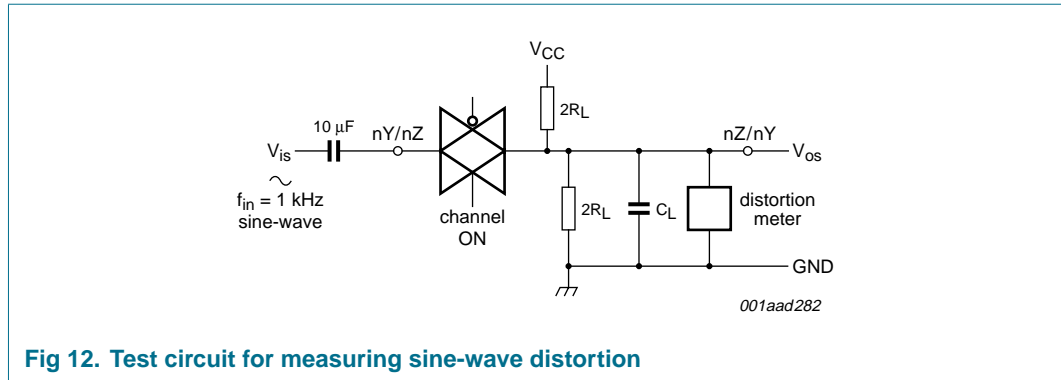

Fig 12. Test circuit for measuring sine-wave distortion

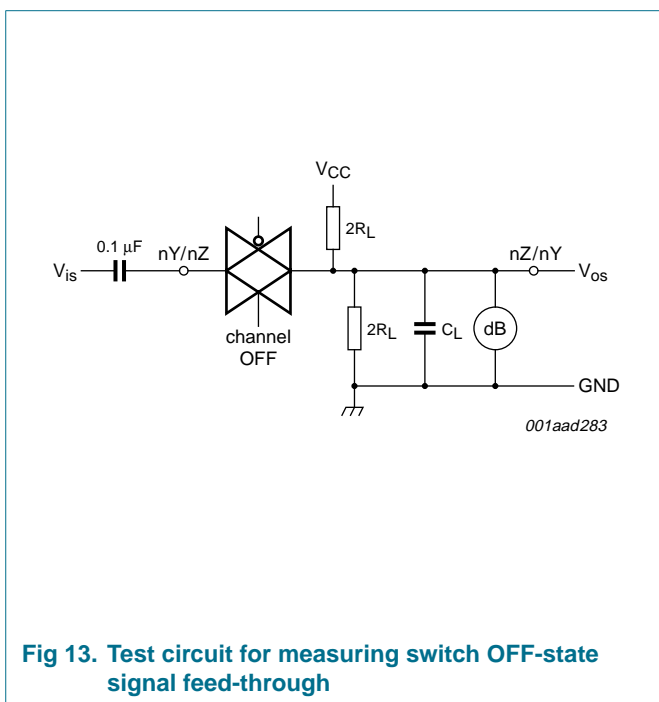

Fig 13. Test circuit for measuring switch OFF-state signal feed-through

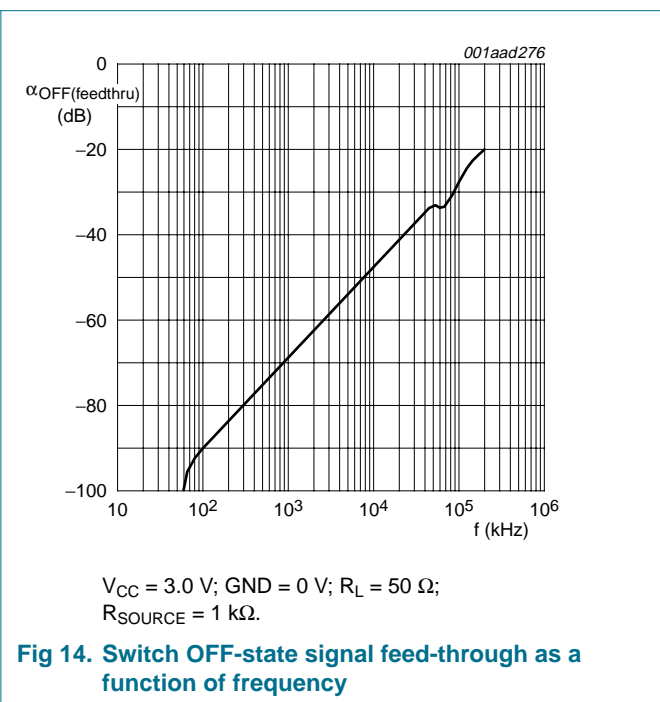

Fig 14. Switch OFF-state signal feed-through as a function of frequency

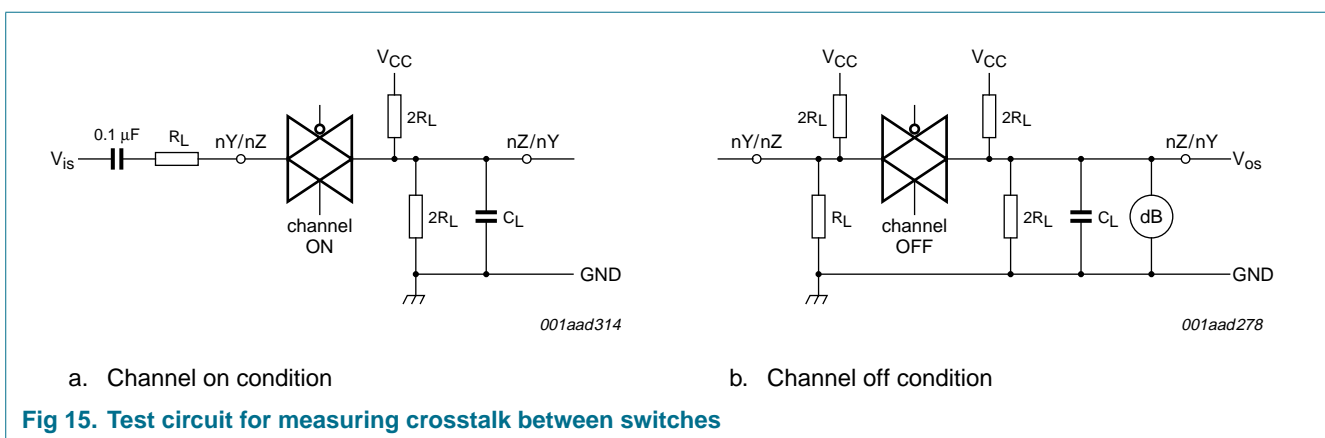

Fig 15. Test circuit for measuring crosstalk between switches

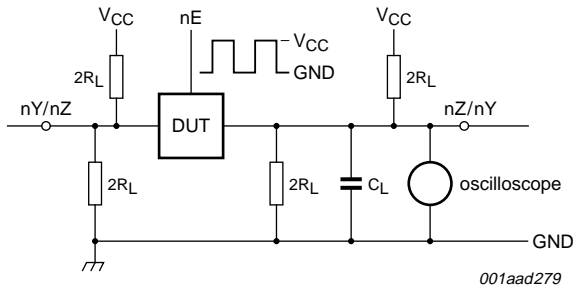

Fig 16. Test circuit for measuring crosstalk between enable and any switch

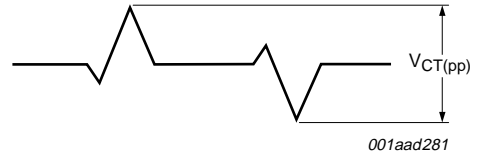

Fig 17. Crosstalk definition (oscilloscope output)

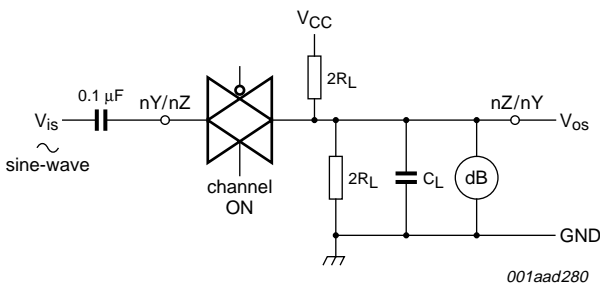
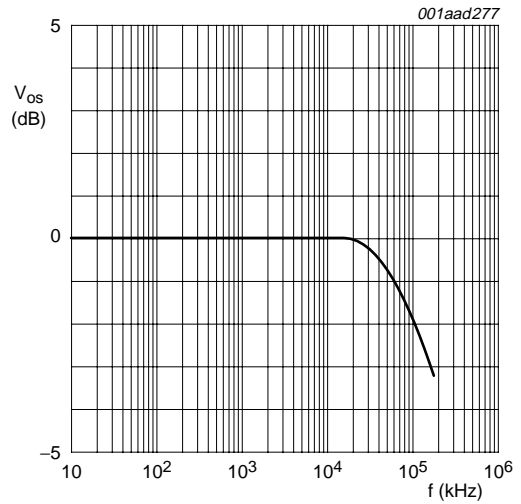

Fig 18. Test circuit for measuring minimum frequency response



$V_{CC} = 3.0\text{ V}; GND = 0\text{ V}; R_L = 50\ \Omega;$   
 $R_{SOURCE} = 1\text{ k}\Omega.$

Fig 19. Frequency response

14. Package outline

DIP14: plastic dual in-line package; 14 leads (300 mil)

SOT27-1

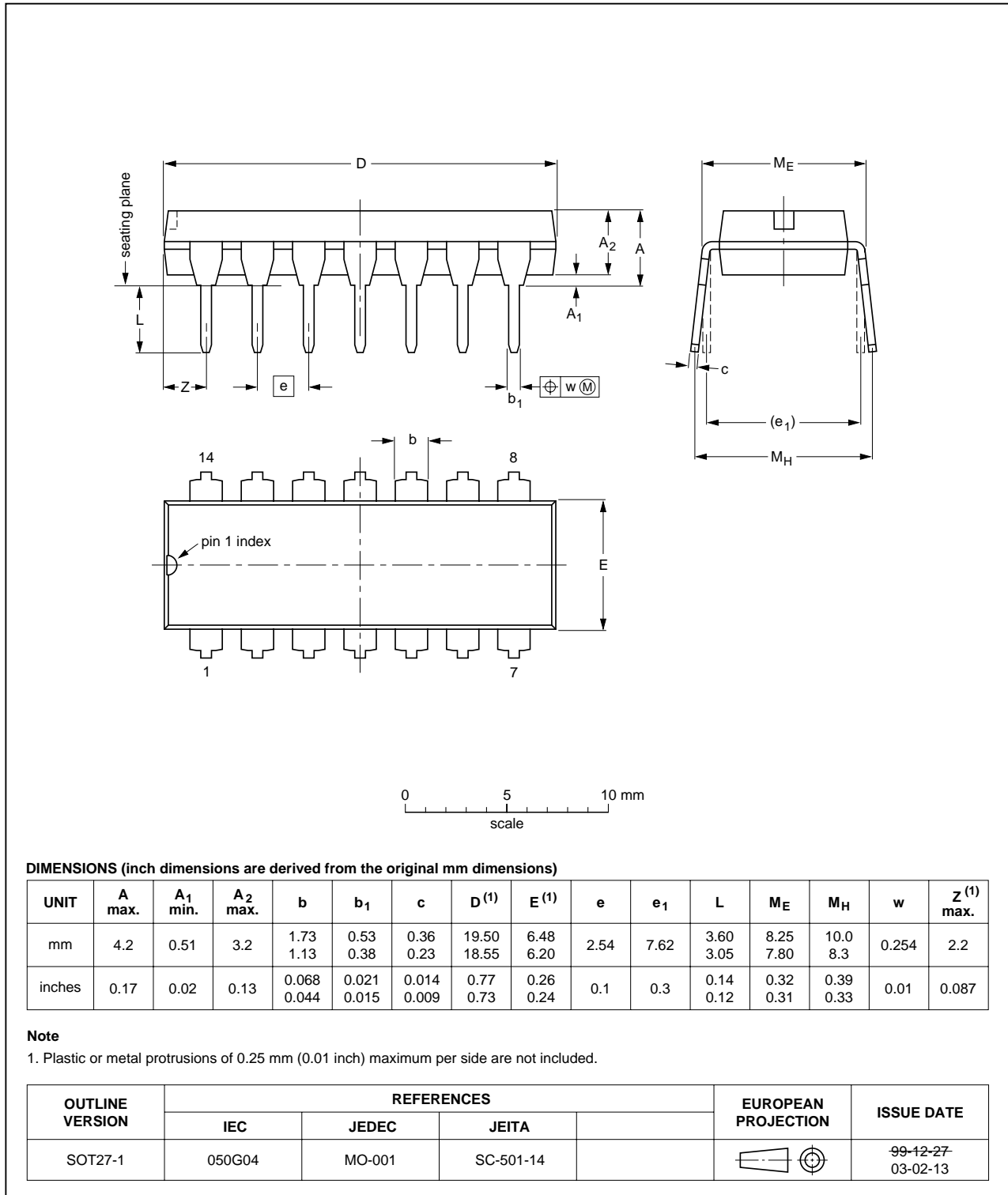

Fig 20. Package outline SOT27-1 (DIP14)

SO14: plastic small outline package; 14 leads; body width 3.9 mm

SOT108-1

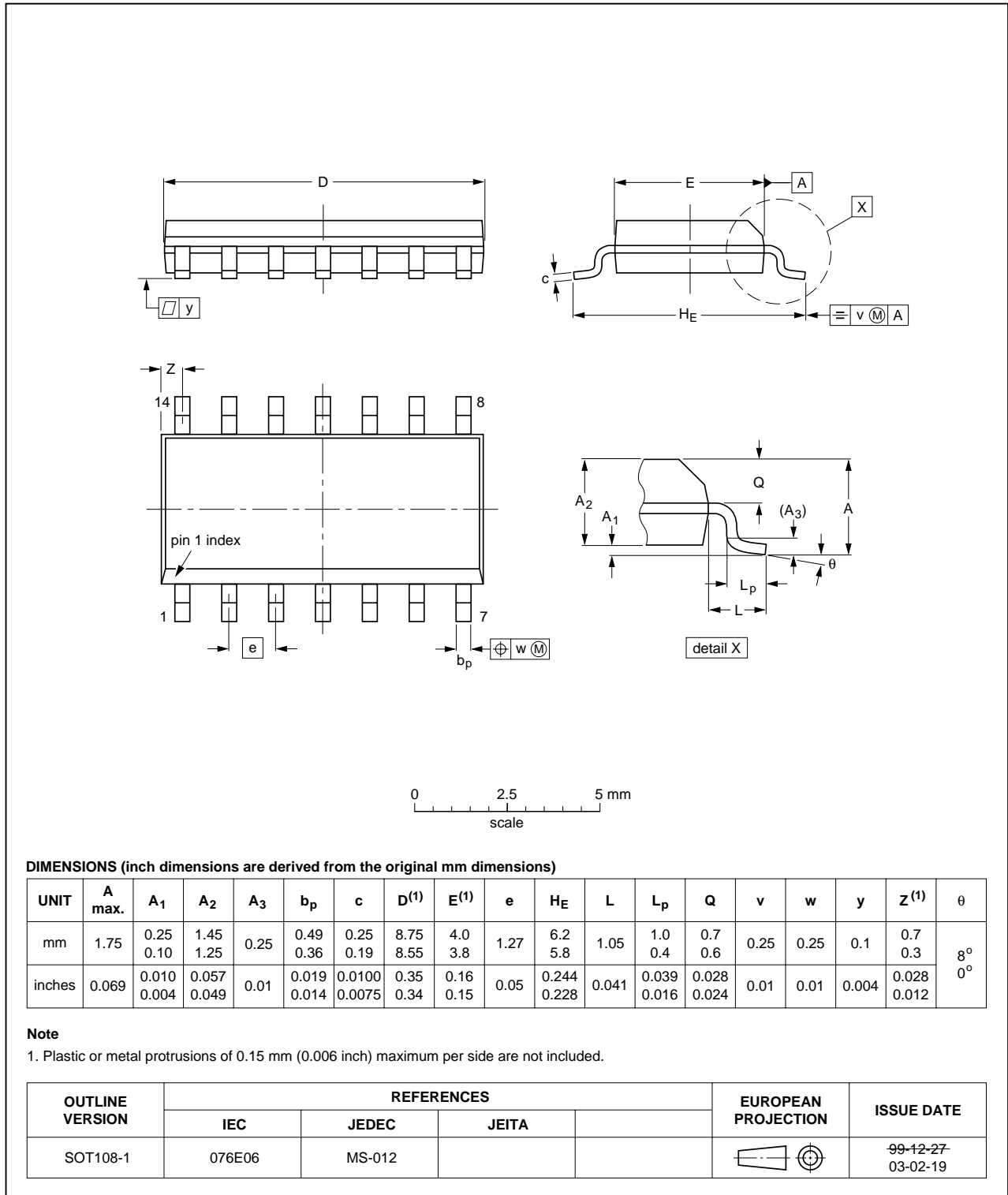

Fig 21. Package outline SOT108-1 (SO14)

SSOP14: plastic shrink small outline package; 14 leads; body width 5.3 mm

SOT337-1

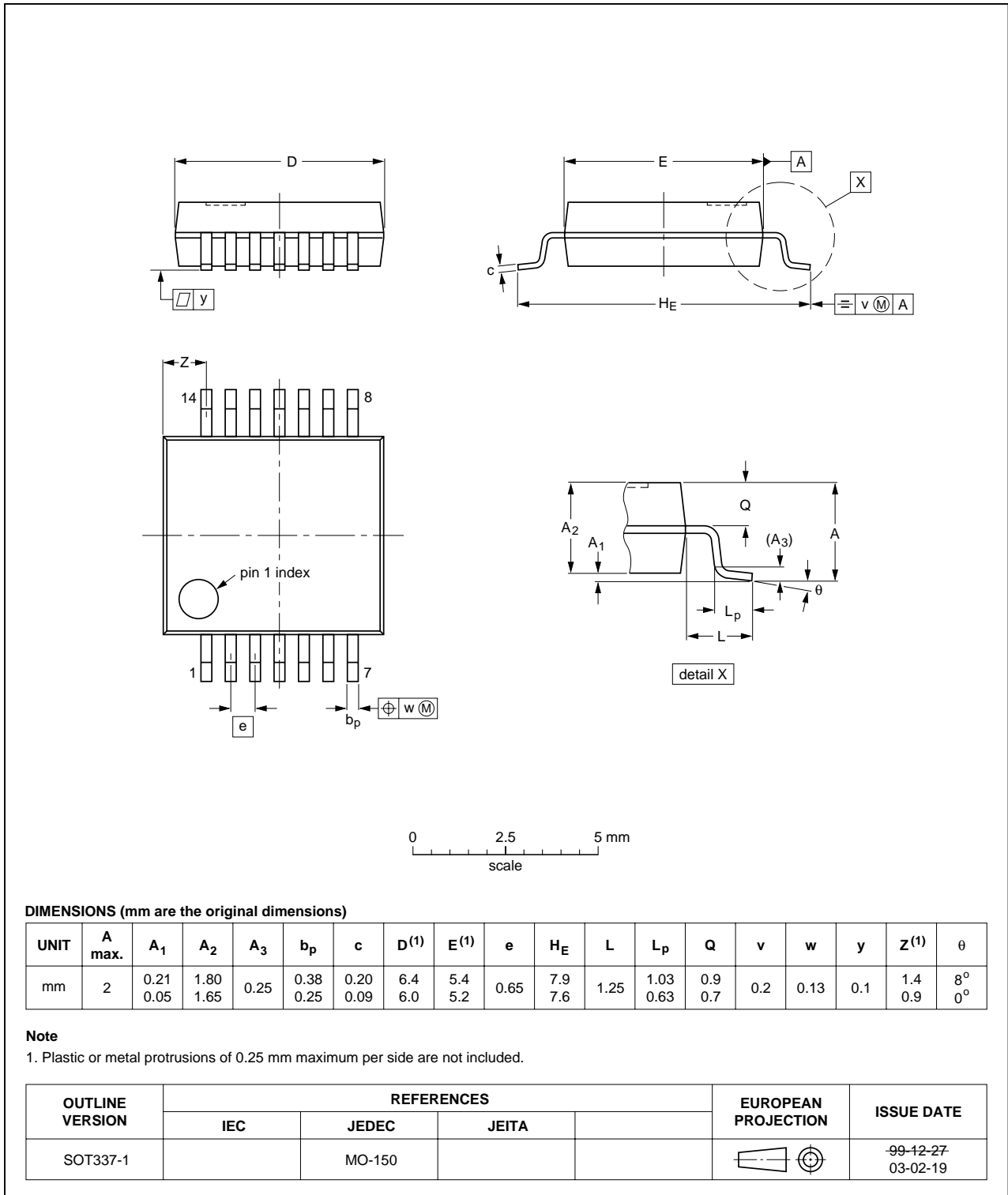

Fig 22. Package outline SOT337-1 (SSOP14)

TSSOP14: plastic thin shrink small outline package; 14 leads; body width 4.4 mm

SOT402-1

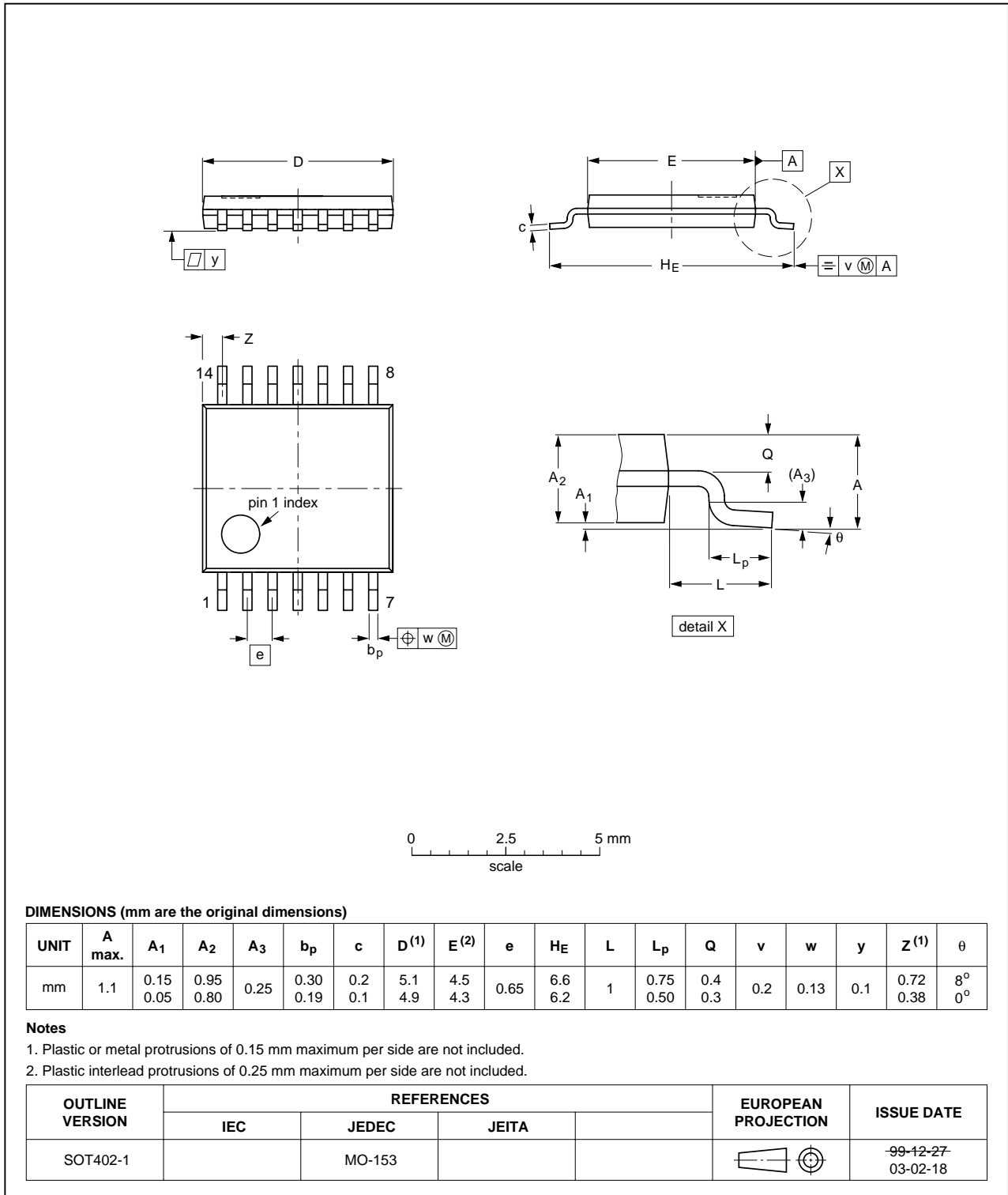

Fig 23. Package outline SOT402-1 (TSSOP14)

## 15. Revision history

**Table 13: Revision history**

Document ID	Release date	Data sheet status	Change notice	Doc. number	Supersedes
74LV4066_3	20050704	Product data sheet	-	9397 750 15209	74LV4066_2
Modifications:	<ul style="list-style-type: none"><li>• The format of this data sheet has been redesigned to comply with the new presentation and information standard of Philips Semiconductors.</li><li>• <a href="#">Table 2</a>: corrected package names.</li></ul>				
74LV4066_2	19980623	Product specification	-	9397 750 04659	-

## 16. Data sheet status

Level	Data sheet status <sup>[1]</sup>	Product status <sup>[2] [3]</sup>	Definition
I	Objective data	Development	This data sheet contains data from the objective specification for product development. Philips Semiconductors reserves the right to change the specification in any manner without notice.
II	Preliminary data	Qualification	This data sheet contains data from the preliminary specification. Supplementary data will be published at a later date. Philips Semiconductors reserves the right to change the specification without notice, in order to improve the design and supply the best possible product.
III	Product data	Production	This data sheet contains data from the product specification. Philips Semiconductors reserves the right to make changes at any time in order to improve the design, manufacturing and supply. Relevant changes will be communicated via a Customer Product/Process Change Notification (CPCN).

[1] Please consult the most recently issued data sheet before initiating or completing a design.

[2] The product status of the device(s) described in this data sheet may have changed since this data sheet was published. The latest information is available on the Internet at URL <http://www.semiconductors.philips.com>.

[3] For data sheets describing multiple type numbers, the highest-level product status determines the data sheet status.

## 17. Definitions

**Short-form specification** — The data in a short-form specification is extracted from a full data sheet with the same type number and title. For detailed information see the relevant data sheet or data handbook.

**Limiting values definition** — Limiting values given are in accordance with the Absolute Maximum Rating System (IEC 60134). Stress above one or more of the limiting values may cause permanent damage to the device. These are stress ratings only and operation of the device at these or at any other conditions above those given in the Characteristics sections of the specification is not implied. Exposure to limiting values for extended periods may affect device reliability.

**Application information** — Applications that are described herein for any of these products are for illustrative purposes only. Philips Semiconductors make no representation or warranty that such applications will be suitable for the specified use without further testing or modification.

## 18. Disclaimers

**Life support** — These products are not designed for use in life support appliances, devices, or systems where malfunction of these products can reasonably be expected to result in personal injury. Philips Semiconductors

## 20. Contact information

For additional information, please visit: <http://www.semiconductors.philips.com>

For sales office addresses, send an email to: [sales.addresses@www.semiconductors.philips.com](mailto:sales.addresses@www.semiconductors.philips.com)

customers using or selling these products for use in such applications do so at their own risk and agree to fully indemnify Philips Semiconductors for any damages resulting from such application.

**Right to make changes** — Philips Semiconductors reserves the right to make changes in the products - including circuits, standard cells, and/or software - described or contained herein in order to improve design and/or performance. When the product is in full production (status 'Production'), relevant changes will be communicated via a Customer Product/Process Change Notification (CPCN). Philips Semiconductors assumes no responsibility or liability for the use of any of these products, conveys no license or title under any patent, copyright, or mask work right to these products, and makes no representations or warranties that these products are free from patent, copyright, or mask work right infringement, unless otherwise specified.

## 19. Trademarks

**Notice** — All referenced brands, product names, service names and trademarks are the property of their respective owners.

## 21. Contents

1	General description . . . . .	1
2	Features . . . . .	1
3	Quick reference data . . . . .	2
4	Ordering information . . . . .	2
5	Functional diagram . . . . .	3
6	Pinning information . . . . .	4
6.1	Pinning . . . . .	4
6.2	Pin description . . . . .	4
7	Functional description . . . . .	4
7.1	Function table . . . . .	4
8	Limiting values . . . . .	5
9	Recommended operating conditions . . . . .	5
10	Static characteristics . . . . .	6
11	Dynamic characteristics . . . . .	10
12	Waveforms . . . . .	12
13	Additional dynamic characteristics . . . . .	14
14	Package outline . . . . .	17
15	Revision history . . . . .	21
16	Data sheet status . . . . .	22
17	Definitions . . . . .	22
18	Disclaimers . . . . .	22
19	Trademarks . . . . .	22
20	Contact information . . . . .	22



© Koninklijke Philips Electronics N.V. 2005

All rights are reserved. Reproduction in whole or in part is prohibited without the prior written consent of the copyright owner. The information presented in this document does not form part of any quotation or contract, is believed to be accurate and reliable and may be changed without notice. No liability will be accepted by the publisher for any consequence of its use. Publication thereof does not convey nor imply any license under patent- or other industrial or intellectual property rights.

Date of release: 4 July 2005  
Document number: 9397 750 15209

Published in The Netherlands



LittleDiode supplies new, hard to find or obsolete electronic components and semiconductors all over the world.

With over two million different components listed you are sure to find the part you need.

Feel free to visit us today at our online store:

[LittleDiode.com](http://LittleDiode.com)

Looking forward to providing you with the best possible service.