

FEATURES

- Wide Bandwidth Switches 0.9 x DC @ 100MHz
- High OFF Isolation. 66 dB @ 100MHz
- Low Channel-to-Channel Crosstalk. . . -80 dB @ 10MHz
- TTL Compatible
- Low ON Resistance
- High Speed
- Low Capacitance

APPLICATIONS

- Glitch-Free Analog Switches
- RF & Video Switches
- Track-and-Hold Switches
- Sample-and-Hold Switches
- High Speed Data Routing

DESCRIPTION

Designed for RF and Video Switching the CWB201 is manufactured using Calogic's high speed CMOS combined with DMOS transistors in a monolithic design resulting in superior performance characteristics. This quad SPST switch array has extensive applications where high frequency video, audio or digital signals are switched or routed. The CWB201 is TTL compatible which is of great benefit to designs that require constant logic switching over a wide range of supply voltages and temperature without a separate power supply.

ORDERING INFORMATION

Part	Package	Temperature Range
CWB201CP	Plastic 16-Pin Dip	0 to +85°C
CWB201CY	Plastic SO-16 Surface Mount	0 to +85°C
XCWB201	Sorted Chips in Carriers	0 to +85°C

PIN CONFIGURATION

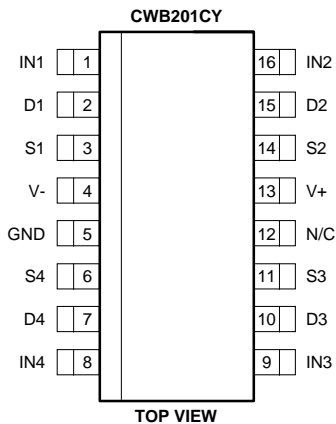
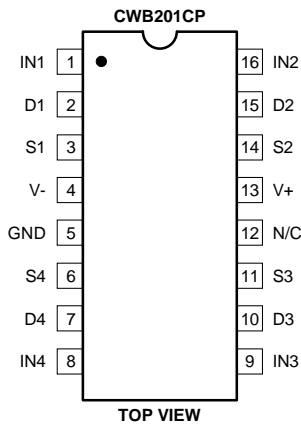

CWB

FUNCTIONAL BLOCK DIAGRAM

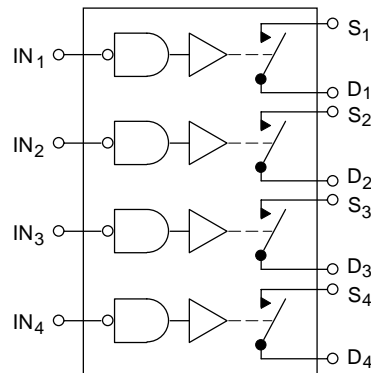

Four SPST Switches per Package.
Switches shown in Logic '1' Input Position.

LOGIC TABLE

Logic	Switch
0	ON
1	OFF

Logic '0' ≤ 0.8V
Logic '1' ≥ 2.42V

NOTE: All devices contain diodes to protect inputs against damage due to high static voltages or electric fields; however, it is advised that precautions be taken not to exceed the maximum recommended input voltages. All unused inputs must be connected to an appropriate logic level (V_{DD} or GND).

ABSOLUTE MAXIMUM RATINGS

V-	Negative Supply Voltage	-20V
V+	Positive Supply Voltage	+20V
V _{IN}	Control Input Voltage Range	V+ +0.3V V- -0.3V
I _L	Continuous Current, any Pin except S or D	20mA
I _S	Continuous Current, S or D	30mA
I _S	Peak Pulsed Current, S or D, 80μsec, 1%, Duty Cycle	90mA
T _J	Junction Temperature Range	-55 to +125°C
T _S	Storage Temperature Range	-55 to +125°C
P _D	Power Dissipation (derate at 5.5mW/°C, above +85°C)	500mW

RECOMMENDED OPERATING CONDITIONS

V-	Negative Supply Voltage	-8.0 to -15V
V+	Positive Supply Voltage	+8.0 to +15V
V _{IN}	Control Input Voltage Range	0 to +5V
T _{OP}	Operating Temperature	0 to 85°C

ELECTRICAL CHARACTERISTICS (T_A = +25°C, V- = -15V, V+ = +15V unless otherwise noted)

SYMBOL	PARAMETER	MIN	TYP	MAX	UNITS	TEST CONDITIONS
STATIC						
V _{ANALOG}	Analog Signal Range	-10		+10	V	
r _{DS(ON)}	Channel ON Resistance		40 45 100	80 80 160	Ω	V _S = -10V V _S = +2.0V V _S = +10V V _{IN} = 0
V _{IH}	High Level Input Voltage	2.4			V	
V _{IL}	Low Level Input Voltage			0.8		
I _{IN}	Logic Input Leakage Current		0.01 0.02	0.1 0.1	μA	V _{IN} = +2.4V V _{IN} = +15V
I _{D(OFF)}	Switch OFF Leakage Current		0.2	5.0	nA	V _D = +10V, V _S = -10V V _S = +10V, V _D = -10V V _{IN} = +2.4V
I _{S(OFF)}			0.4	5.0		
I-	Negative Supply Quiescent Current		-0.3	-1.0	mA	V _{IN} = 0 or +2.4V
I+	Positive Supply Quiescent Current		0.6	2.0		
DYNAMIC						
t _{ON}	Switch Turn-ON Time		400	600	nsec	See Switching Times Test Circuit
t _{OFF}	Switch Turn-OFF Time		70	300		
O _I RR	OFF Isolation Rejection Ratio	60	66		dB	f = 10MHz, R _L = 50Ω
C _{CRR}	Cross Coupling Rejection Ratio		80			
C _d	Drain-Node Capacitance		0.3		pF	V _D = V _S = 0 f = 1MHz V _{IN} = +2.4V
C _s	Source-Node Capacitance		3.0			

ELECTRICAL CHARACTERISTICS (V- = -15V, V+ = +15V unless otherwise noted)

LIMITS AT TEMPERATURE EXTREMES

SYMBOL	PARAMETER	MAXIMUM @ T _A =		UNITS	TEST CONDITIONS
		+85°C			
STATIC					
V _{ANALOG}	Analog Signal Range	±10		V	
r _{DS(ON)}	Switch ON Resistance	120 120 240		Ω	V _S = -10V V _S = +2.0V V _S = +10V V _{IN} = 0
I _{IN}	Logic Input Leakage Current	1.0 2.0		μA	V _{IN} = +2.4V V _{IN} = +15V
I _{D(OFF)}	Switch OFF Leakage Current	100		nA	V _D = +10V, V _S = -10V V _S = +10V, V _D = -10V V _{IN} = +2.4V
I _{S(OFF)}		100			
I-	Supply Quiescent Current	-1.0		mA	V _{IN} = 0 or +2.4V
I+		2.0			

TYPICAL PERFORMANCE CHARACTERISTICS ($T_A = +25^\circ\text{C}$ unless otherwise specified)

SWITCHING TIMES TEST CIRCUIT

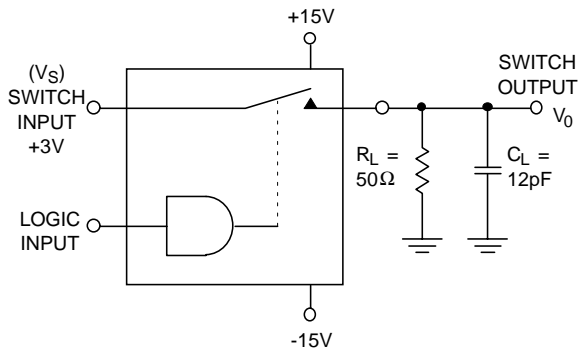

SWITCH ILLUSTRATED IN LOGIC '1',
SWITCH OFF, POSITION

TEST WAVEFORMS

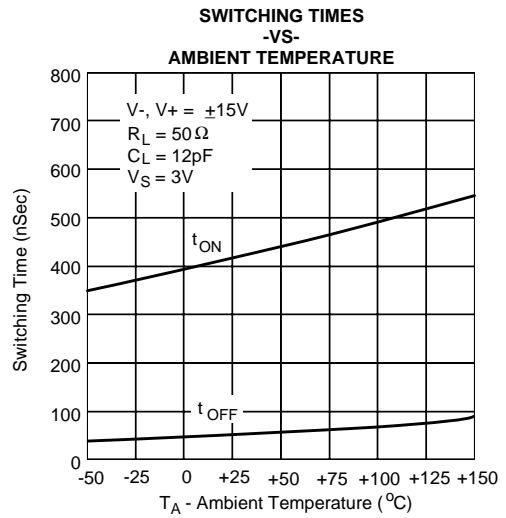
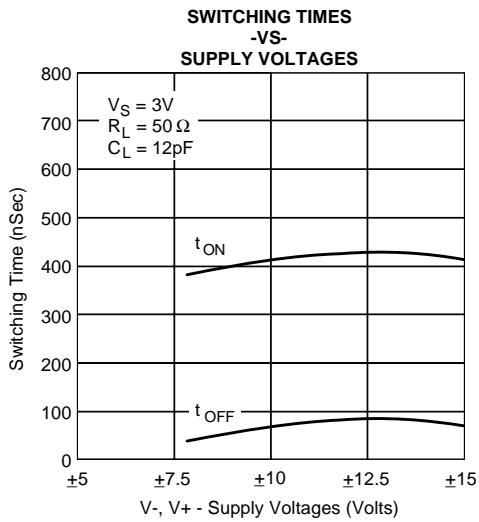
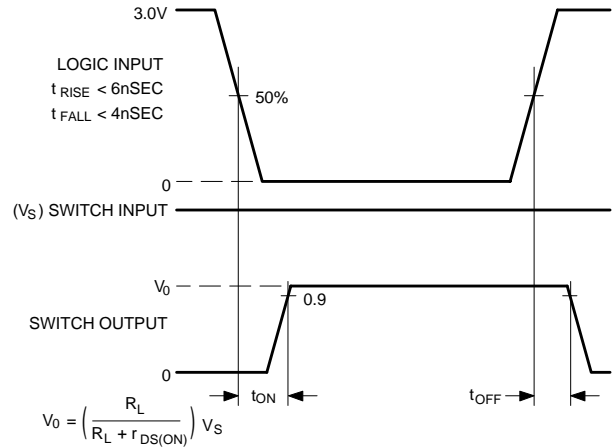

TYPICAL PERFORMANCE CHARACTERISTICS ($T_A = +25^\circ\text{C}$ unless otherwise specified)

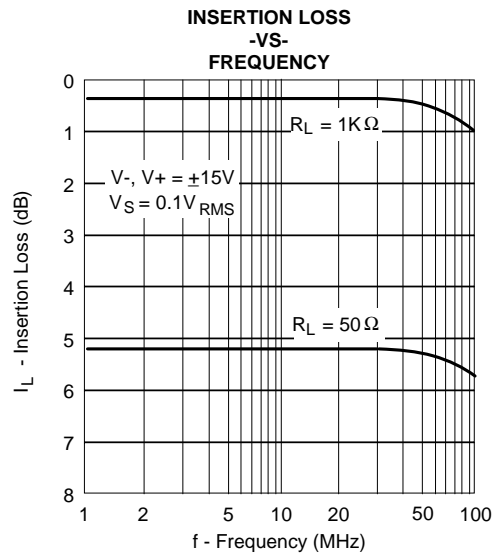
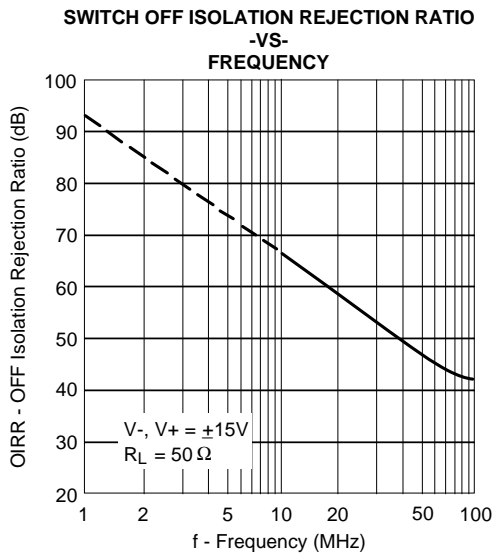
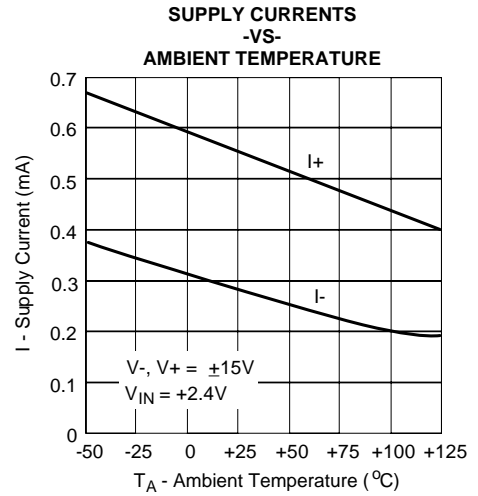
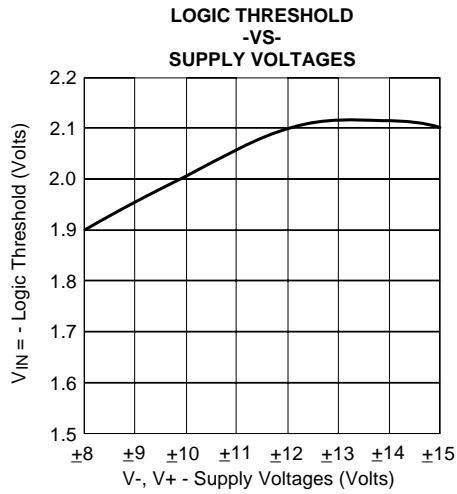

TYPICAL PERFORMANCE CHARACTERISTICS ($T_A = +25^\circ\text{C}$ unless otherwise specified)

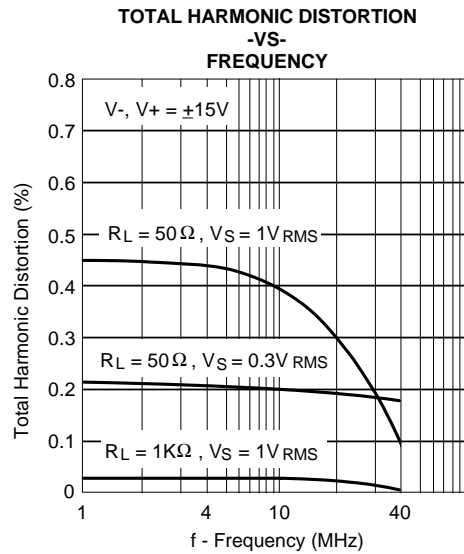
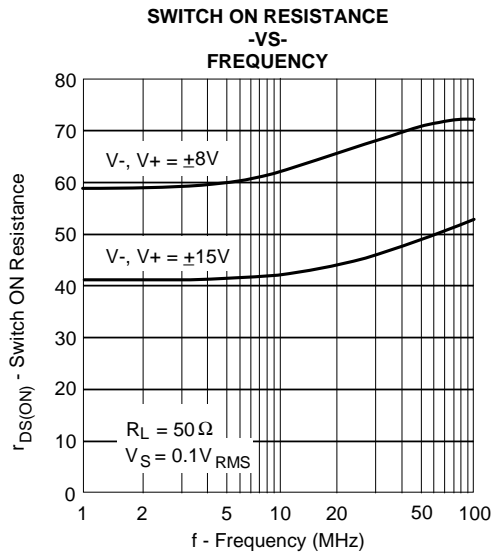
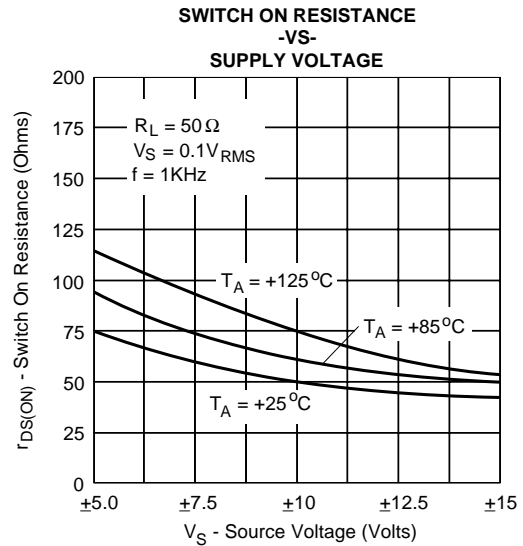
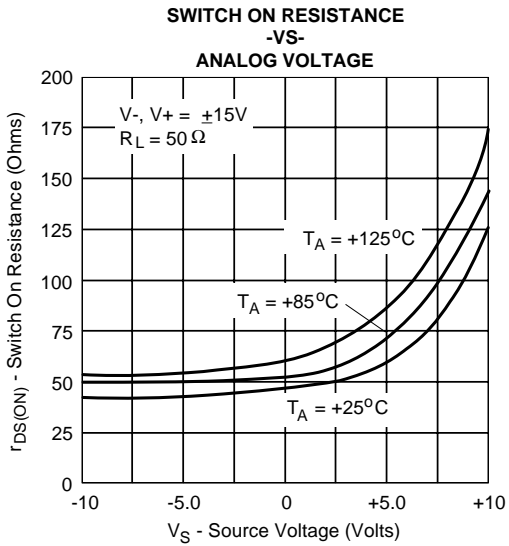



LittleDiode supplies new, hard to find or obsolete electronic components and semiconductors all over the world.

With over two million different components listed you are sure to find the part you need.

Feel free to visit us today at our online store:

LittleDiode.com

Looking forward to providing you with the best possible service.