

# Fault-Protected Single 8-Ch/Differential 4-Ch Analog Multiplexers

## FEATURES

- Fault and Overvoltage Protection
- All Channels Off When Power Off
- Latchup-Proof
- Fast Switching— $T_A$ : 200 ns
- Break-Before-Make Switching
- Low On-Resistance: 180  $\Omega$
- Low Power Consumption: 3 mW
- TTL and CMOS Compatible Inputs

## BENEFITS

- Improved Ruggedness
- Power Loss Protection
- Prevents Adjacent Channel Crosstalk
- Standard Logic Interface
- Superior Accuracy
- Fast Settling Time

## APPLICATIONS

- Data Acquisition Systems
- Industrial Process Control Systems
- Avionics Test Equipment
- High-Rel Control Systems
- Telemetry

## DESCRIPTION

The DG458 and DG459 are 8-channel single-ended and 4-channel differential analog multiplexers, respectively, incorporating fault protection. A series n-p-n MOSFET structure provides device and signal-source protection in the event of power loss or overvoltages. Under fault conditions the multiplexer input (or output) appears as an open circuit and only a few nanoamperes of leakage current will flow. This protects not only the multiplexer and the circuitry following it, but also protects the sensors or signal sources which drive the multiplexer.

The DG458 and DG459 can withstand continuous overvoltage inputs up to  $\pm 35$  V. All digital inputs have TTL compatible logic thresholds. Break-before-make operation prevents channel-to-channel interference.

The DG458 and DG459 are improved pin-compatible replacements for HI-508A/509A and MAX358/359 multiplexers.

## FUNCTIONAL BLOCK DIAGRAM AND PIN CONFIGURATION

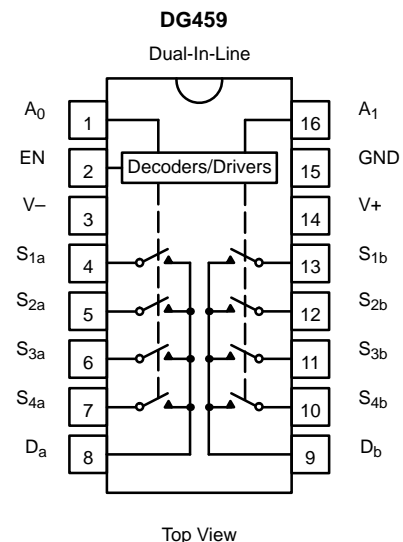
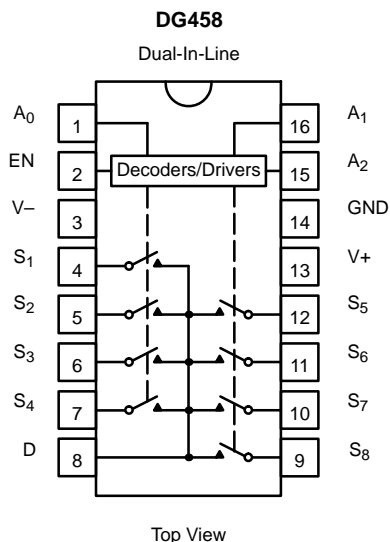



**TRUTH TABLES AND ORDERING INFORMATION**

TRUTH TABLE — DG458				
A <sub>2</sub>	A <sub>1</sub>	A <sub>0</sub>	EN	On Switch
X	X	X	0	None
0	0	0	1	1
0	0	1	1	2
0	1	0	1	3
0	1	1	1	4
1	0	0	1	5
1	0	1	1	6
1	1	0	1	7
1	1	1	1	8

TRUTH TABLE — DG459			
A <sub>1</sub>	A <sub>0</sub>	EN	On Switch
X	X	0	None
0	0	1	1
0	1	1	2
1	0	1	3
1	1	1	4

Logic "0" = V<sub>AL</sub> ≤ 0.8 V  
 Logic "1" = V<sub>AH</sub> ≥ 2.4 V  
 X = Don't Care

ORDERING INFORMATION		
Temp Range	Package	Part Number
-40 to 85°C	16-Pin Plastic DIP	DG458DJ
		DG459DJ
-55 to 125°C	16-Pin CerDIP	DG458AK/883
		DG459AK/883
	LCC-20	DG458AZ/883
		DG459AZ/883

\*Block Diagram and Pin Configuration not shown.

**ABSOLUTE MAXIMUM RATINGS**

V <sub>+</sub> to V <sub>-</sub>	44 V
V <sub>+</sub> to GND	22 V
V <sub>-</sub> to GND	-25 V
V <sub>EN</sub> , V <sub>A</sub> Digital Input	(V <sub>-</sub> ) -4 V to (V <sub>+</sub> ) +4 V
V <sub>S</sub> , Analog Input Overvoltage with Power On	(V <sub>-</sub> ) -20 V to (V <sub>+</sub> ) +20 V
V <sub>S</sub> , Analog Input Overvoltage with Power Off	-35 V to +35 V
Continuous Current, S or D	20 mA
Peak Current, S or D (Pulsed at 1 ms, 10% Duty Cycle Max)	40 mA

Storage Temperature	(AK Suffix)	-65 to 150°C
	(DJ Suffix)	-65 to 125°C

Power Dissipation (Package) <sup>a</sup>	
16-Pin Plastic DIP <sup>b</sup>	600 mW
16-Pin CerDIP <sup>c</sup>	1000 mW
LCC-20 <sup>d</sup>	1000 mW

- Notes:
- All leads soldered or welded to PC board.
  - Derate 6.3 mW/°C above 25°C.
  - Derate 12 mW/°C above 75°C.
  - Derate 10 mW/°C above 75°C.



SPECIFICATIONS <sup>a</sup>										
Parameter	Symbol	Test Conditions Unless Otherwise Specified		Temp <sup>b</sup>	Typ <sup>c</sup>	A Suffix -55 to 125°C		D Suffix -40 to 85°C		Unit
		$V_+ = 15\text{ V}, V_- = -15\text{ V}$ $V_{AL} = 0.8\text{ V}, V_{AH} = 2.4\text{ V}^f$				Min <sup>d</sup>	Max <sup>d</sup>	Min <sup>d</sup>	Max <sup>d</sup>	
<b>Analog Switch</b>										
Analog Signal Range <sup>9</sup>	$V_{ANALOG}$			Full		-10	10	-10	10	V
Drain-Source On-Resistance	$r_{DS(on)}$	$V_D = \pm 9.5\text{ V}, I_S = -400\ \mu\text{A}$		Room Full	0.45		1.2		1.5	k $\Omega$
		$V_D = \pm 5\text{ V}, I_S = -400\ \mu\text{A}$		Room	180		400		400	$\Omega$
$r_{DS(on)}$ Matching Between Channels <sup>h</sup>	$\Delta r_{DS(on)}$	$V_D = 0\text{ V}, I_S = -400\ \mu\text{A}$		Room	6					%
Source Off Leakage Current	$I_{S(off)}$	$V_{EN} = 0\text{ V}$ $V_S = \pm 10\text{ V}, V_D = \mp 10\text{ V}$		Room Full	0.03	-0.5 -50	0.5 50	-1 -20	1 20	nA
Drain Off Leakage Current	$I_{D(off)}$	$V_{EN} = 0\text{ V}$ $V_D = \pm 10\text{ V}$ $V_S = \mp 10\text{ V}$	DG458	Room Full	0.1	-1 -200	1 200	-1 -50	1 50	
			DG459	Room Full	0.1	-1 -100	1 100	-2 -25	2 25	
Differential Off Drain Leakage Current	$I_{DIFF}$	DG459 Only		Room		-50	50	-20	20	
Drain On Leakage Current	$I_{D(on)}$	$V_S = V_D = \pm 10\text{ V}$	DG458	Room Full	0.1	-2 -200	2 200	-5 -50	5 50	
			DG459	Room Full	0.05	-2 -100	2 100	-5 -25	5 25	
<b>Fault</b>										
Output Leakage Current (with Overvoltage)	$I_{D(off)}$	$V_S = \pm 33\text{ V}, V_D = 0\text{ V}$ See Figure 2		Room	0.02					nA
Input Leakage Current (with Overvoltage)	$I_{S(off)}$	$V_S = \pm 25\text{ V}, V_D = \pm 10\text{ V}$ See Figure 2		Room	0.005	-5	5	-10	10	$\mu\text{A}$
Input Leakage Current (with Power Supplies Off)		$V_S = \pm 25\text{ V}, V_{SUPS} = 0\text{ V}$ $V_D = A_0, A_1, A_2, EN = 0\text{ V}$		Room	0.001	-2	2	-5	5	
<b>Digital Control</b>										
Input Low Threshold	$V_{AL}$			Full			0.8		0.8	V
Input Low Threshold	$V_{AL}$			Full		2.4		2.4		
Logic Input Control	$I_A$	$V_A = 2.4\text{ V}$ or $0.8\text{ V}$		Full		-1	1	-1	1	$\mu\text{A}$
<b>Dynamic Characteristics</b>										
Transition Time	$t_A$	See Figure 3		Room	200		500		500	ns
Break-Before-Make Time	$t_{OPEN}$	See Figure 4		Room	45	10		10		
Enable Turn-On Time	$t_{ON(EN)}$	See Figure 5		Room Full	140		250 500		250 500	
Enable Turn-Off Time	$t_{OFF(EN)}$			Room Full	50		250 500		250 500	
Settling Time	$t_s$	To 0.1 %		Room	0.5					$\mu\text{s}$
		To 0.01%		Room	1.5					
Off Isolation	OIRR	$V_{EN} = 0\text{ V}, R_L = 1\text{ k}\Omega, C_L = 15\text{ pF}, V_S = 3\text{ V}_{RMS}, f = 100\text{ kHz}$		Room	90					dB
Logic Input Capacitance	$C_{in}$	$f = 1\text{ MHz}$		Room	5					pF
Source Off Capacitance	$C_{S(off)}$			Room	5					
Drain Off Capacitance	$C_{D(off)}$			DG458	Room	15				
				DG459	Room	10				
Drain On Capacitance	$C_{D(on)}$			DG458	Room	40				
				DG459	Room	35				



SPECIFICATIONS <sup>a</sup>									
Parameter	Symbol	Test Conditions Unless Otherwise Specified $V_+ = 15\text{ V}, V_- = -15\text{ V}$ $V_{AL} = 0.8\text{ V}, V_{AH} = 2.4\text{ V}^f$	Temp <sup>b</sup>	Typ <sup>c</sup>	A Suffix -55 to 125°C		D Suffix -40 to 85°C		Unit
					Min <sup>d</sup>	Max <sup>d</sup>	Min <sup>d</sup>	Max <sup>d</sup>	
<b>Power Supplies</b>									
Positive Supply Current	I+	$V_{EN} = 5.0\text{ or }0\text{ V}, V_A = 0\text{ V}$	Room Full	0.05		0.1 0.2		0.1 0.2	mA
Negative Supply Current	I-		Room Full	-0.01	-0.1 -0.2		-0.1 -0.2		
Power Supply Range for Continuous Operation			Room		±4.5	±18	±4.5	±18	V

Notes:

- a. Refer to PROCESS OPTION FLOWCHART.
- b. Room = 25°C, Full = as determined by the operating temperature suffix.
- c. Typical values are for DESIGN AID ONLY, not guaranteed nor subject to production testing.
- d. The algebraic convention whereby the most negative value is a minimum and the most positive a maximum, is used in this data sheet.
- e. Guaranteed by design, not subject to production test.
- f.  $V_{IN}$  = input voltage to perform proper function.
- g. When the analog signal exceeds the +13.5 V or -12 V,  $r_{DS(on)}$  starts to rise until only leakage currents flow.

$$h. \Delta r_{DS(on)} = \left( \frac{r_{DS(on) \text{ MAX}} - r_{DS(on) \text{ MIN}}}{r_{DS(on) \text{ AVE}}} \right) \times 100\%$$

**TYPICAL CHARACTERISTICS (25°C UNLESS NOTED)**

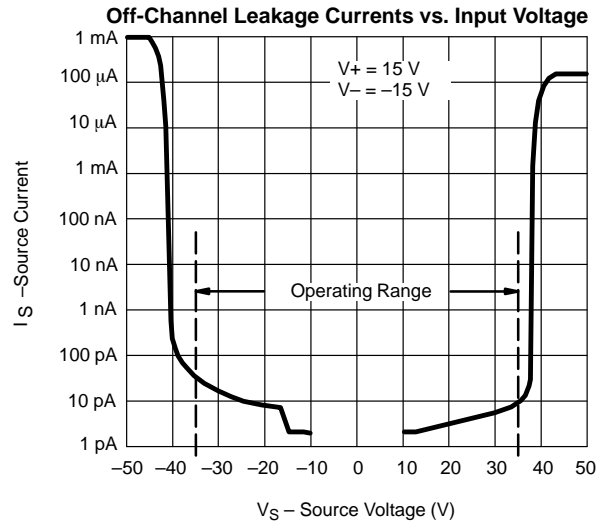
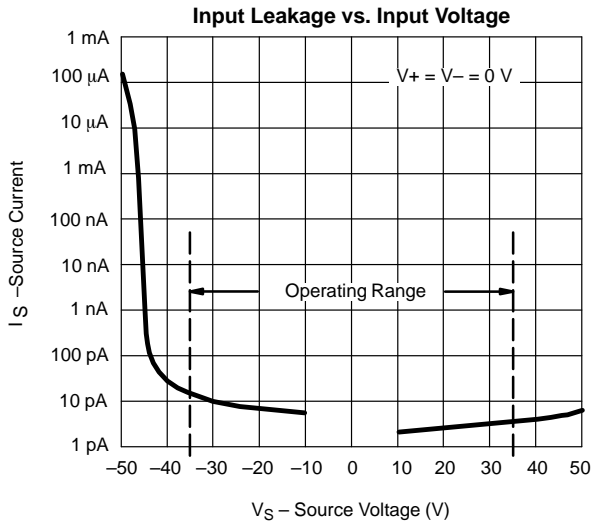

**TYPICAL CHARACTERISTICS (25°C UNLESS NOTED)**

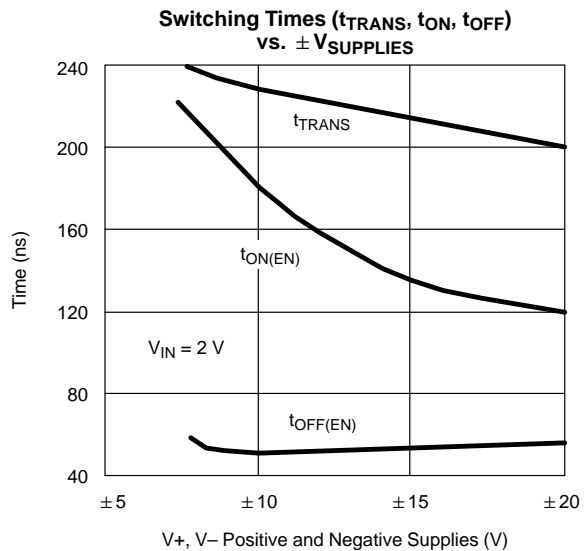
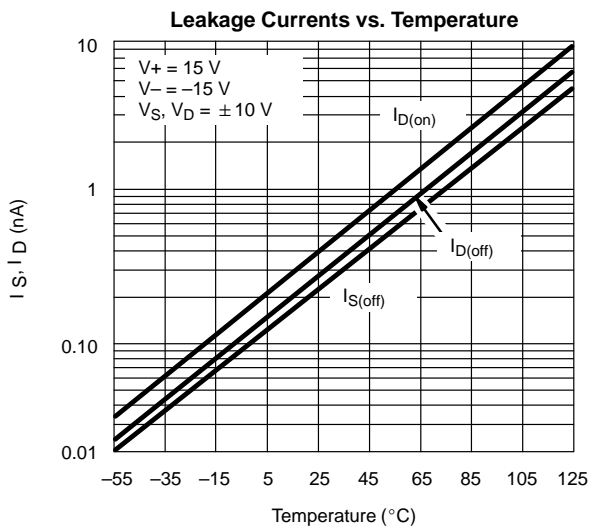
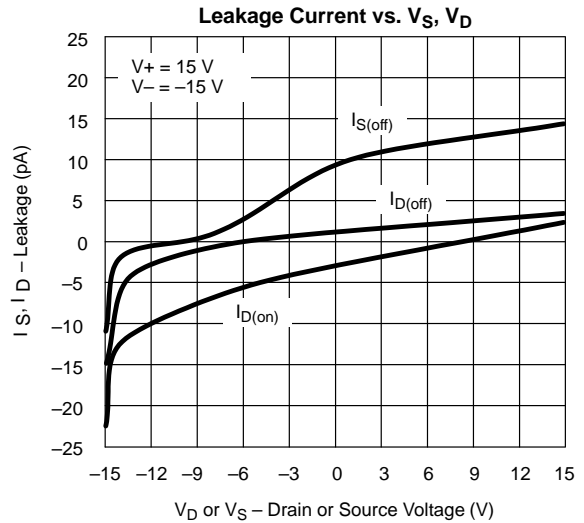
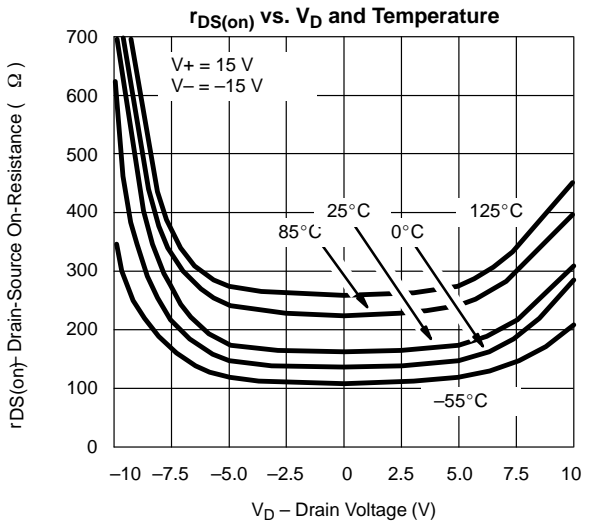
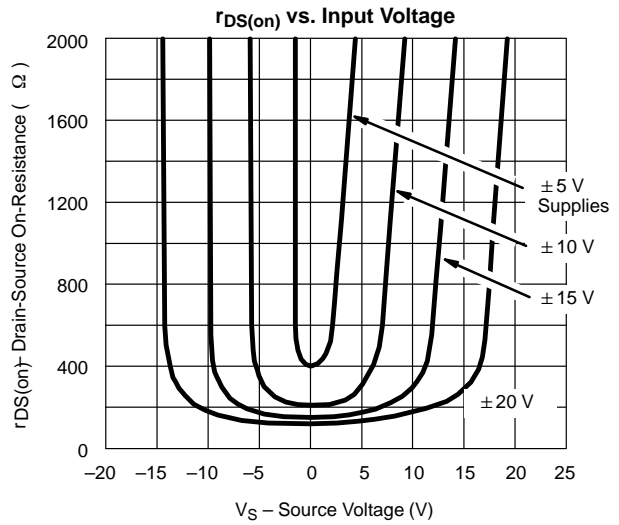
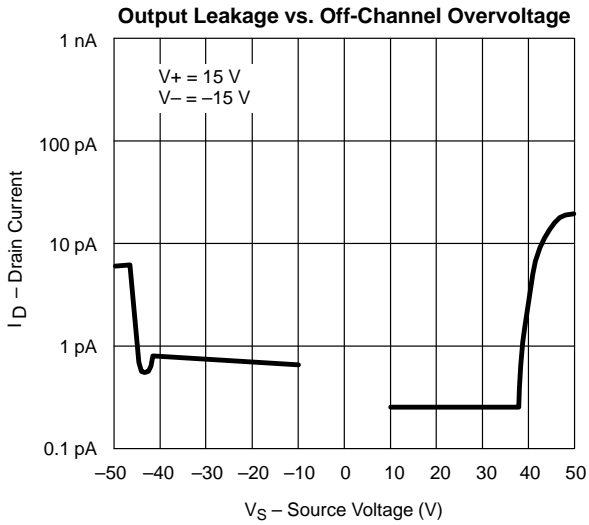

**TYPICAL CHARACTERISTICS (25°C UNLESS NOTED)**

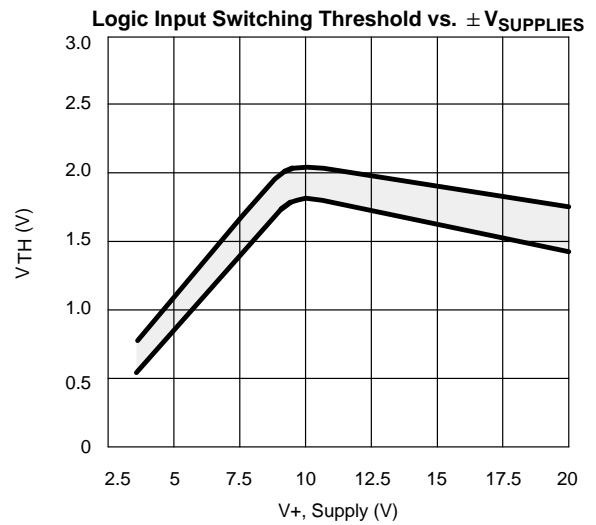
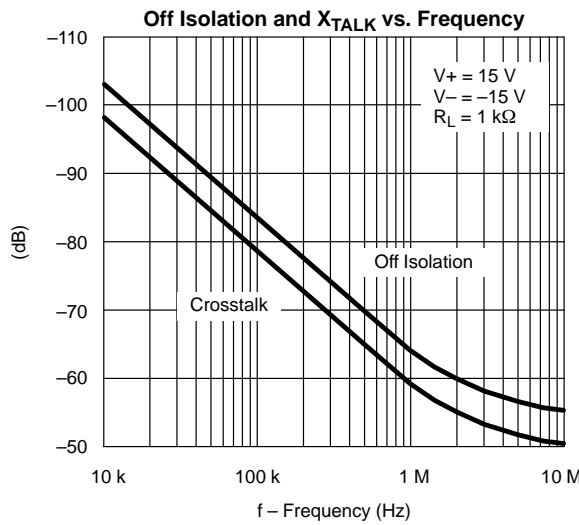
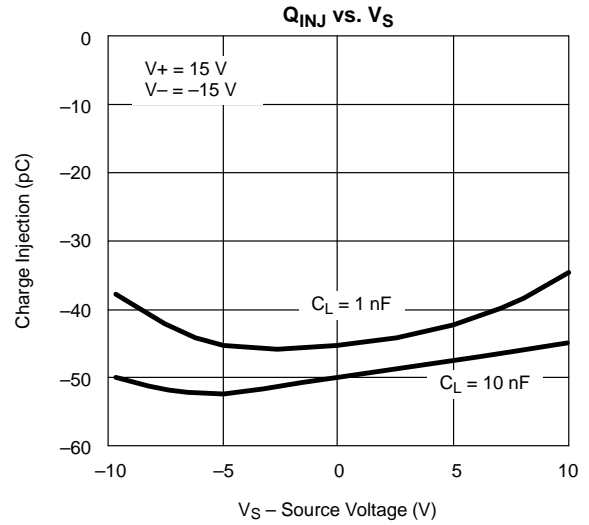
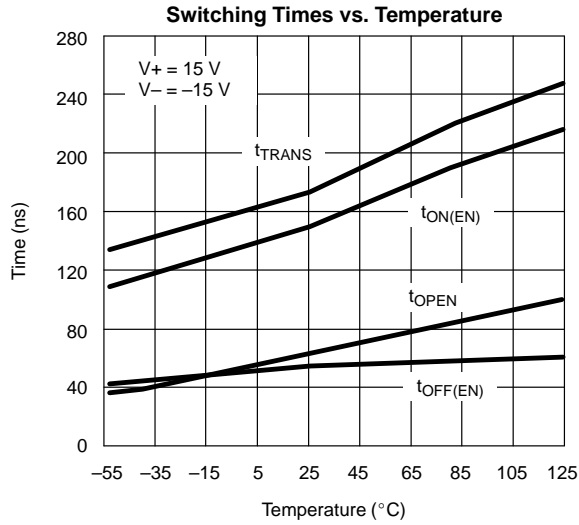

**SCHEMATIC DIAGRAM (TYPICAL CHANNEL)**

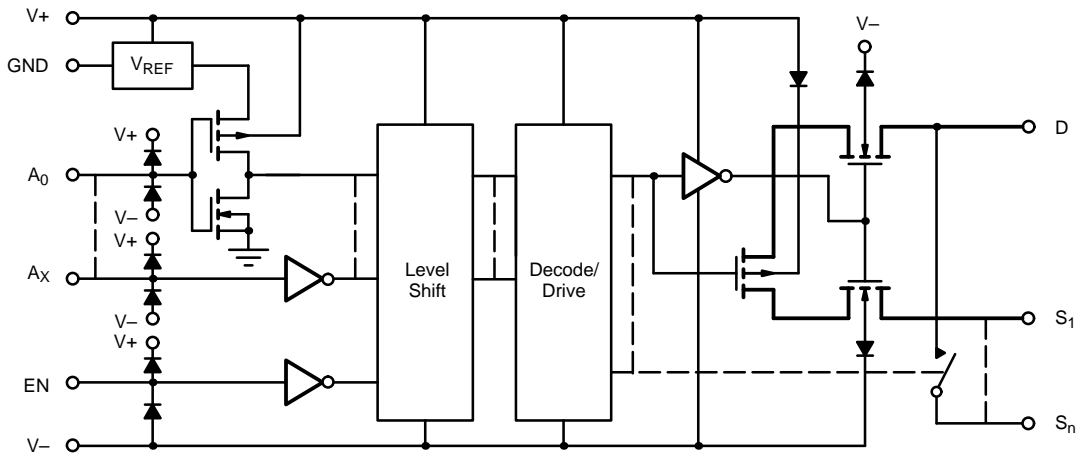
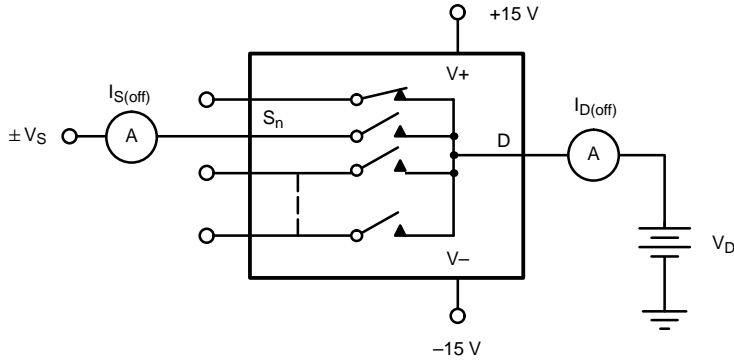
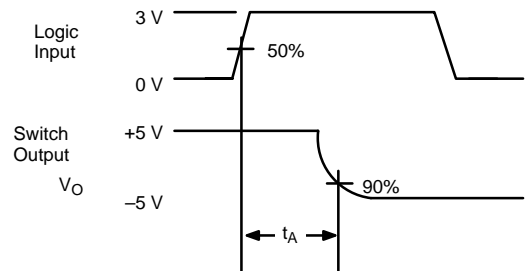
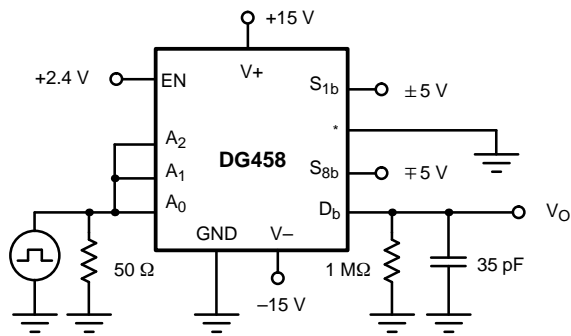

FIGURE 1.

**TEST CIRCUITS**

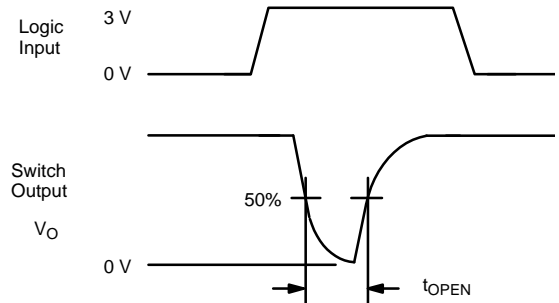
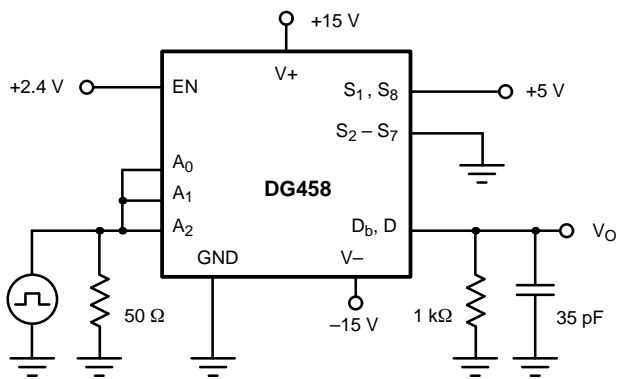

**FIGURE 2.** Analog Input Overtolerance



\* = S<sub>1a</sub> - S<sub>8a</sub>, S<sub>2b</sub> - S<sub>7b</sub>, D<sub>a</sub>

**FIGURE 3.** Transition Time



**FIGURE 4.** Break-Before-Make Time

**TEST CIRCUITS**

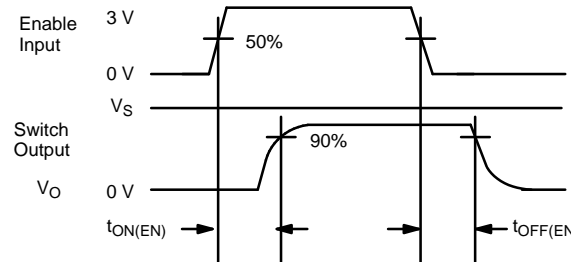
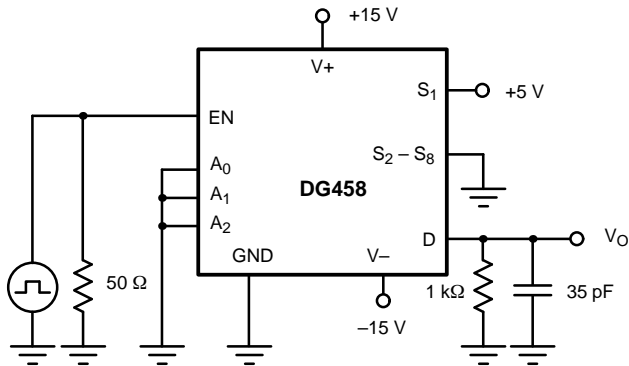

FIGURE 5. Enable Delay

**DETAILED DESCRIPTION**

The Vishay Siliconix DG458 and DG459 multiplexers are fully fault- and overvoltage-protected for continuous input voltages up to  $\pm 35$  V whether or not voltage is applied to the power supply pins ( $V+$ ,  $V-$ ). These multiplexers are built on a high-voltage junction-isolated silicon-gate CMOS process. Two n-channel and one p-channel MOSFETs are connected in series to form each channel (Figure 1).

Within the normal analog signal range ( $\pm 10$  V), the  $r_{DS(on)}$  variation as a function of analog signal voltage is comparable to that of the classic parallel N-MOS and P-MOS switches.

When the analog signal approaches or exceeds either supply rail, even for an on-channel, one of the three series MOSFETs gets cut-off, providing inherent protection against overvoltages even if the multiplexer power supply voltages are lost. This protection is good up to the breakdown voltage of the respective series MOSFETs. Under fault conditions only sub microamp leakage currents can flow in or out of the multiplexer. This not only provides protection for the multiplexer and succeeding circuitry, but it allows normal, undisturbed operation of all other channels. Additionally, in case of power loss to the multiplexer, the loading caused on the transducers and signal sources is insignificant, therefore redundant multiplexers can be used on critical applications such as telemetry and avionics.

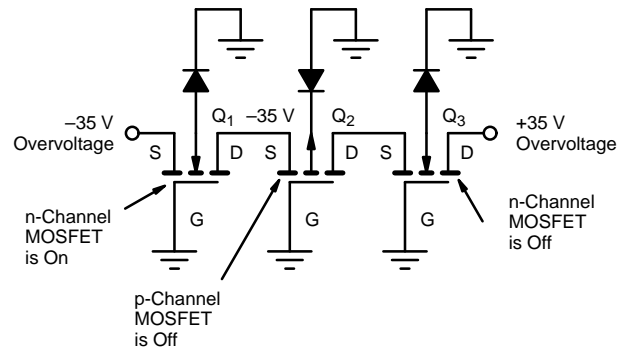

(a) Overvoltage with Multiplexer Power Off

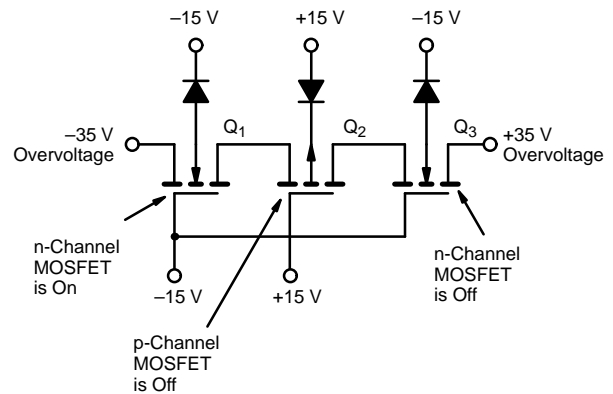

(b) Overvoltage with Multiplexer Power On

FIGURE 6. Overvoltage Protection

This datasheet has been downloaded from:

[www.DatasheetCatalog.com](http://www.DatasheetCatalog.com)

Datasheets for electronic components.



LittleDiode supplies new, hard to find or obsolete electronic components and semiconductors all over the world.

With over two million different components listed you are sure to find the part you need.

Feel free to visit us today at our online store:

[LittleDiode.com](http://LittleDiode.com)

Looking forward to providing you with the best possible service.