

TV VERTICAL DEFLECTION OUTPUT CIRCUIT

- DRIVES VERTICAL DEFLECTION WINDINGS DIRECTLY
- HIGH EFFICIENCY
- INTERNAL FLYBACK GENERATOR
- THERMAL PROTECTION
- ON-CHIP VOLTAGE REFERENCE
- HIGH OUTPUT CURRENT (2.2 A peak)
- 16-LEAD POWERDIP PLASTIC PACKAGE

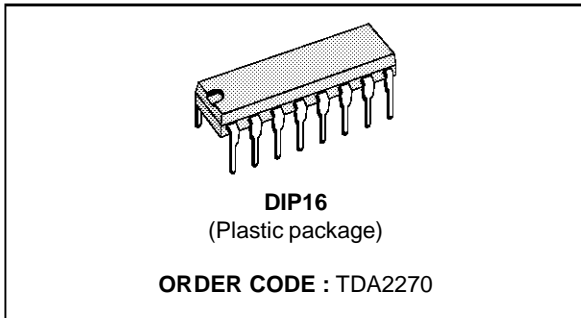

DESCRIPTION

The TDA2270 is a high efficiency monolithic output stage for vertical deflection circuits in TVs and monitors. Driving the vertical windings directly, the device contains a power amplifier, flyback generator, voltage reference and thermal protection circuit.

The TDA2270 is supplied in a 16-pin DIP with the four center pins connected together and used for heatsinking.

PIN CONNECTIONS

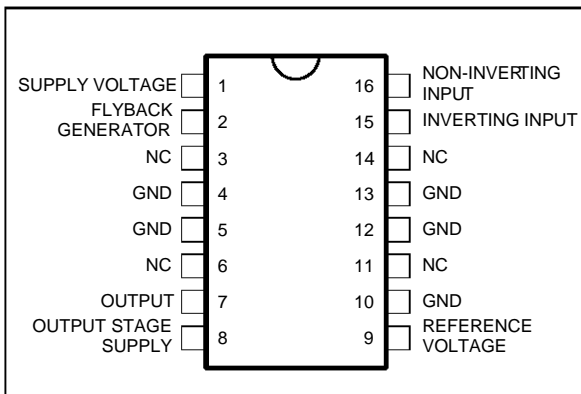

BLOCK DIAGRAM

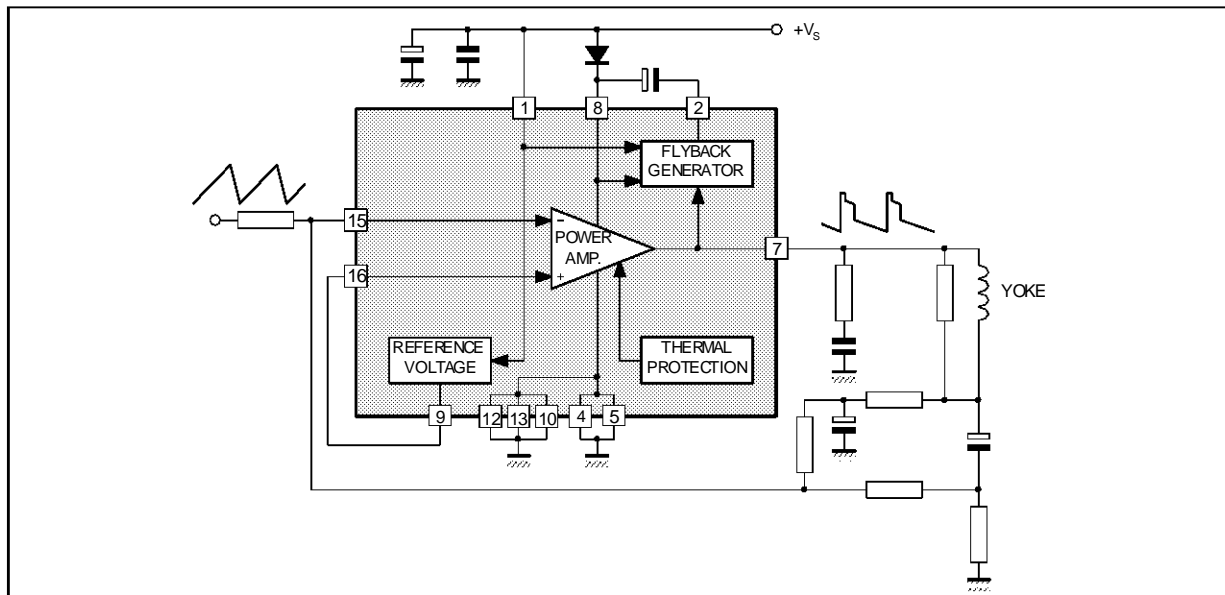

ABSOLUTE MAXIMUM RATINGS

Symbol	Parameter	Value	Unit
V _s	Supply Voltage (pin 1)	35	V
V ₇ , V ₈	Flyback Peak Voltage	60	V
V ₂	Voltage at Pin 2	+ V _s	
V ₁₅ , V ₁₆	Amplifier Input Voltage	+ V _s , - 0.5	V
I _o	Output Peak Current (non repetitive, t = 2 ms)	2	A
I _o	Output Peak Current at f = 50 Hz, t ≤ 10 μs	2.2	A
I _o	Output Peak Current at f = 50 Hz, t > 10 μs	1.2	A
I ₂	Pin 2 DC Current at V ₇ < V ₁	50	mA
I ₂	Pin 2 Peak to Peak Flyback Current at f = 50 Hz, t _{fly} ≤ 1.5 ms	2	A
P _{tot}	Total Power Dissipation at T _{pins} ≤ 90 °C T _{amb} = 70 °C	4.3 1	W W
T _{stg} , T _j	Storage and Junction Temperature	- 40 to 150	°C

2270-01.TBL

THERMAL DATA

Symbol	Parameter	Value	Unit
R _{th j-case}	Thermal Resistance Junction-case	Max 14	°C/W
R _{th j-amb}	Thermal Resistance Junction-ambient	Max 80	°C/W

2270-02.TBL

* Obtained with the GND pins soldered to printed circuit with minimized copper area.

ELECTRICAL CHARACTERISTICS

(refer to the test circuits, V_s = 35 V, T_{amb} = 25°C unless otherwise specified)

Symbol	Parameter	Test Conditions	Min.	Typ.	Max.	Unit	Fig.
I ₁	Pin 1 Quiescent Current	I ₂ = 0, I ₇ = 0, V ₁₆ = 3 V		8	16	mA	1a
I ₈	Pin 8 Quiescent Current	I ₂ = 0, I ₇ = 0, V ₁₆ = 3 V		16	36	mA	1a
I ₁₅	Amplifier Input Bias Current	V ₁₅ = 1 V		- 0.1	- 1	μA	1a
I ₁₆	Amplifier Input Bias Current	V ₁₆ = 1 V		- 0.1	- 1	μA	1a
V _{2L}	Pin 2 Saturation Voltage to GND	I ₂ = 20 mA		1		V	1c
V ₇	Quiescent Output Voltage	V _s = 35 V, R _a = 39 kΩ V _s = 15 V, R _a = 13 kΩ		18 7.5		V V	1d 1d
V _{7L}	Output Saturation Voltage to GND	I ₇ = 0.7 A		0.7	1	V	1c
V _{7H}	Output Saturation Voltage to Supply	- I ₇ = 0.7 A		1.3	1.8	V	1b
V ₉	Reference Voltage	I ₉ = 0		2.2		V	1a
$\frac{\Delta V_9}{\Delta V_s}$	Reference Voltage Drift versus Supply Voltage	V _s = 15 to 30 V		1	2	mV/V	1a
R ₉	Reference Voltage Output Resistance			2.1		kΩ	
T _j	Junction Temperature for Thermal Shut Down			140		°C	

2270-03.TBL

Figure 1 : DC Test Circuits

Figure 1a : Measurement of I_1 ; I_8 ; I_{15} ; I_{16} ; V_9 ; $\Delta V_9/\Delta V_S$; R_9

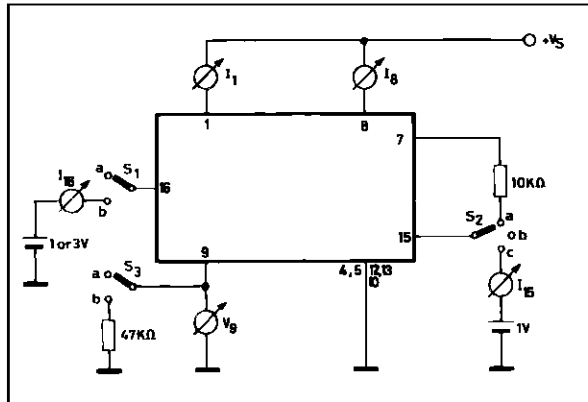

2270-03.EPS

S1 : (a) I_{15} ; (b) I_{16} , I_7 and I_8 .
 S2 : (a) I_7 and I_8 ; (b) I_{16} , (c) I_{15} .
 S3 : (a) I_{15} , I_{16} , I_7 , I_8 , I_9 and V_9 ; (b) R_9

Figure 1b : Measurement of V_{7H}

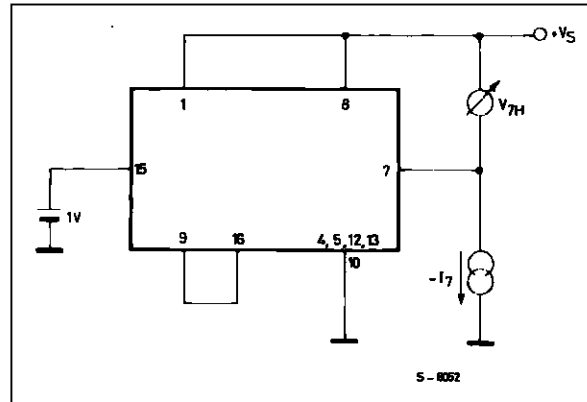

2270-04.EPS

Figure 1c : Measurement of V_{2L} ; V_{7L}

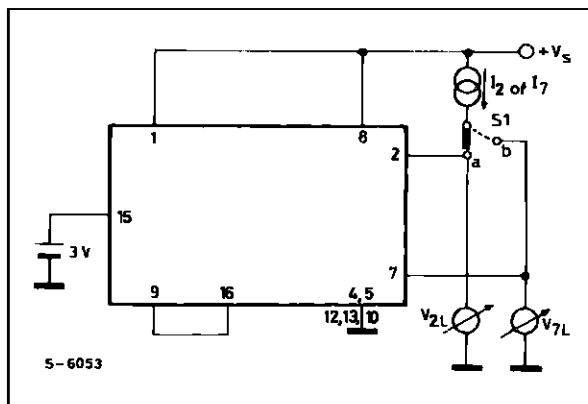

2270-05.EPS

S1 : (a) V_{2L} ; (b) V_{7L}

Figure 1d : Measurement of V_7

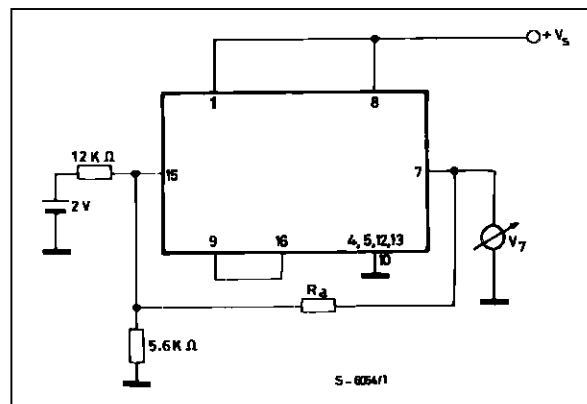

2270-06.EPS

TDA2270

Figure 2 : Application Circuit

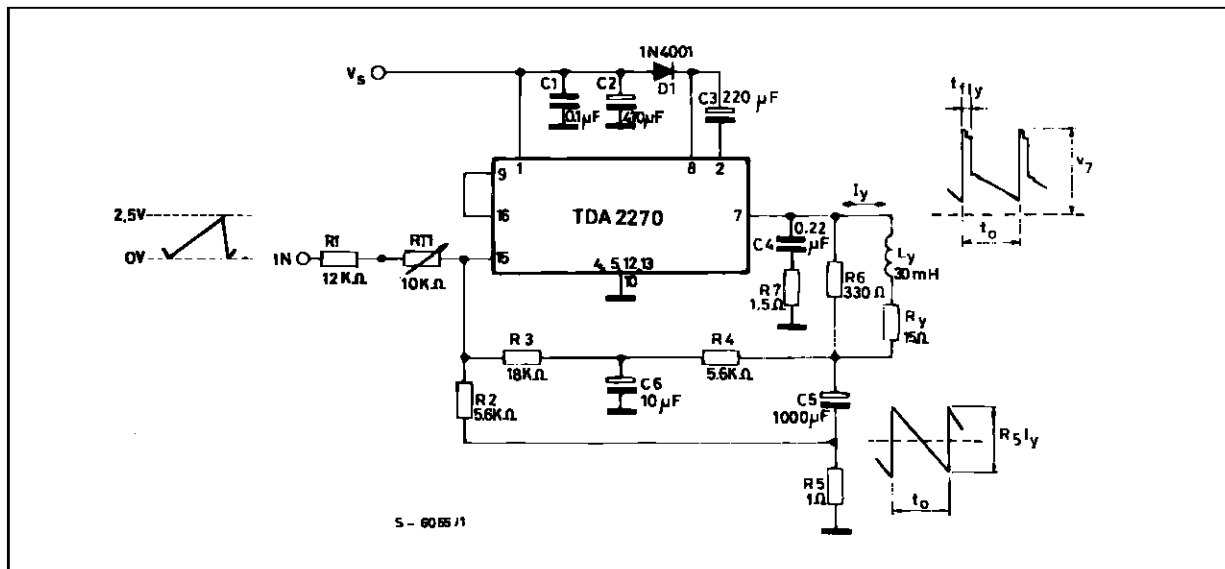
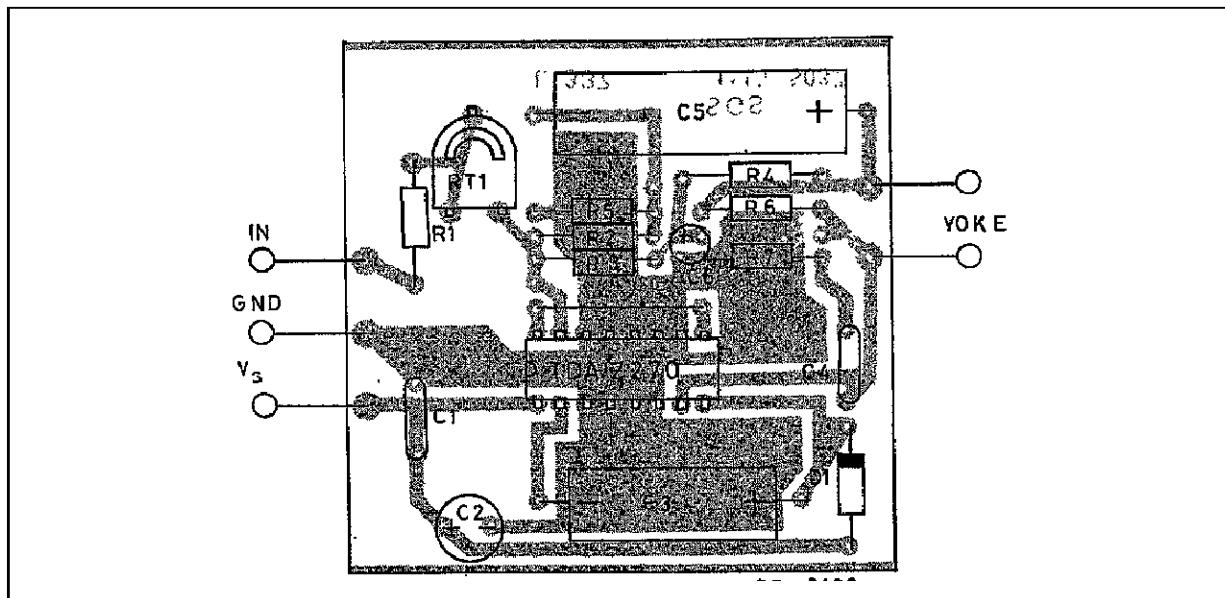

Figure 3 : PC Board and Component Layout (1 : 1 scale)



COMPONENTS LIST FOR TYPICAL APPLICATIONS (refer to the fig. 2)

Component	B/W TV 10 Ω / 20 mH / 1 App	90° TVC 15 Ω / 30 mH / 0.82 App	Unit
RT1	10	10	k Ω
R1	10	12	k Ω
R2	5.6	5.6	k Ω
R3	15	18	k Ω
R4	6.8	5.6	k Ω
R5	1	1	Ω
R6	330	330	Ω
R7	1.5	1.5	Ω
D1	1N 4001	1N 4001	–
C1	0.1	0.1	μ F
C2 el.	470/25 V	470/25 V	μ F
C3 el.	220/25 V	220/25 V	μ F
C4	0.22	0.22	μ F
C5 el.	1000/25 V	1000/16 V	μ F
C6 el.	10/16 V	10/16 V	μ F

2270-04.TBL

TYPICAL PERFORMANCE

Parameter	B/W TV 10 Ω / 20 mH / 1 App	90° TVC 15 Ω / 30 mH	Unit
V_s – Supply Voltage	20	25	V
I_s – Current	145	125	mA
t_{fly} – Flyback Time	0.75	0.7	ms
* P_{tot} – Power Dissipation	1.8	2.05	W
* $R_{th\ c-a}$ – Heatsink	14	12	$^{\circ}$ C/W
T_{amb}	60	60	$^{\circ}$ C
$T_{j\ max}$	130	130	$^{\circ}$ C
t_o	20	20	ms
V_i	2.5	2.5	Vpp
V_7 – Flyback Voltage	42	52	Vp

2270-05.TBL

MOUNTING INSTRUCTIONS

The $R_{th\ j-amb}$ of the TDA 2270 can be reduced by soldering the GND pins to a suitable copper area of the printed circuit board (fig. 4) or to an external heatsink (fig. 5).

The diagram of figure 6 shows the maximum dissippable power P_{tot} and the $R_{th\ j-amb}$ as a function of the side "l" of two equal square copper areas having

a thickness of $35\ \mu$ (1.4 mils).

During soldering the pins temperature must not exceed $260\ ^\circ\text{C}$ and the soldering time must not be longer than 12 seconds.

The external heatsink or printed circuit copper area must be connected to electrical ground.

Figure 4 : Example of P.C. Board Copper Area which is Used as Heatsink

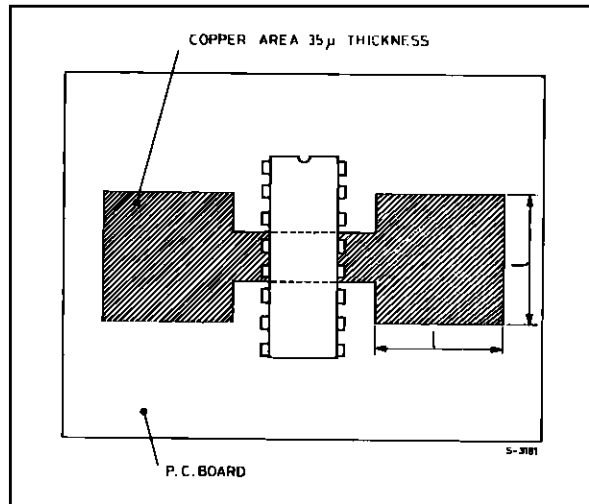

2270-09.EPS

Figure 5 : External Heatsink Mounting Example

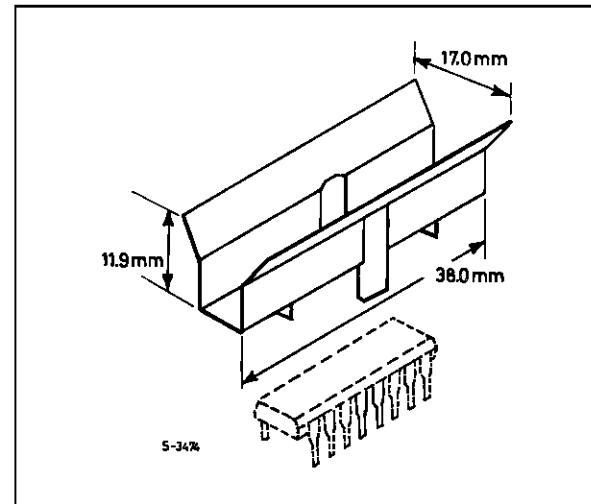

2270-10.EPS

Figure 6 : Maximum Dissippable Power and Junction to Ambient Thermal Resistance versus Side "l"

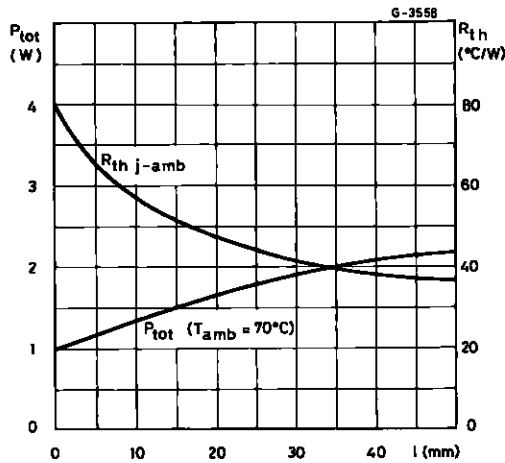

2270-11.EPS

Figure 7 : Maximum Allowable Power Dissipation versus Ambient Temperature

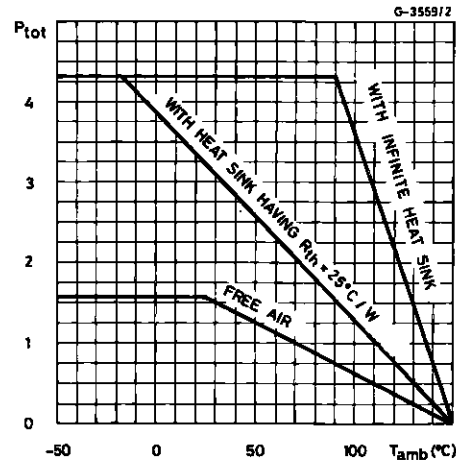

2270-12.EPS

PACKAGE MECHANICAL DATA
16 PINS - PLASTIC DIP

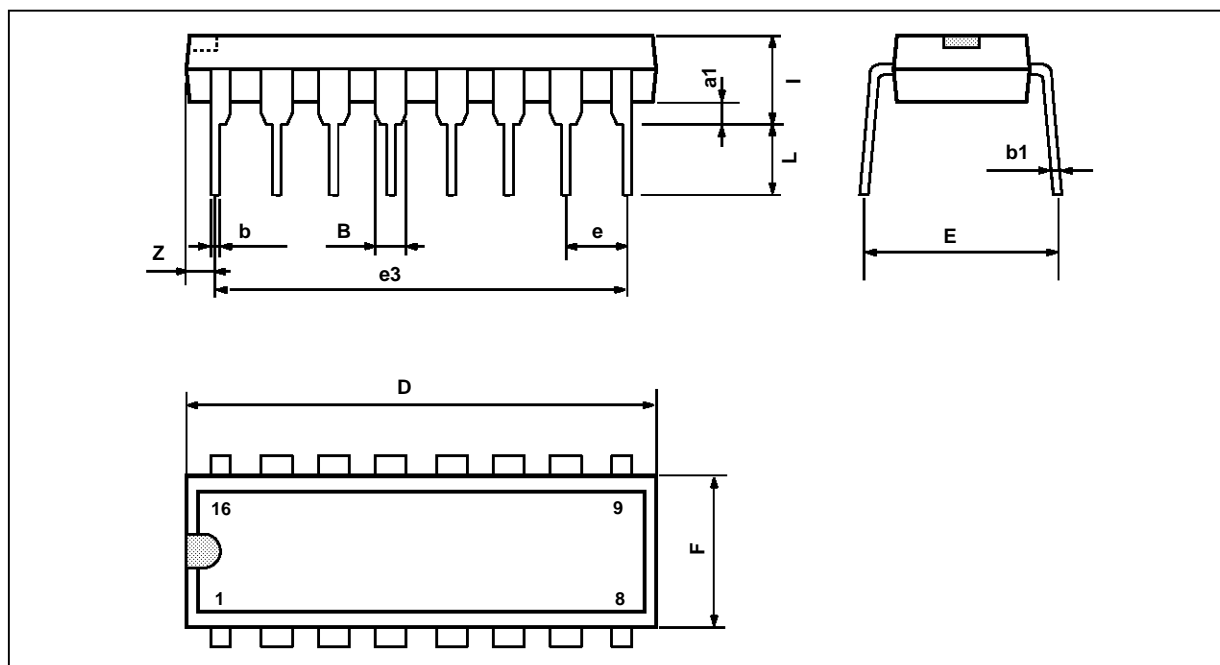

PM-DIP16.EPS

Dimensions	Millimeters			Inches		
	Min.	Typ.	Max.	Min.	Typ.	Max.
a1	0.51			0.020		
B	0.77		1.65	0.030		0.065
b		0.5			0.020	
b1		0.25			0.010	
D			20			0.787
E		8.5			0.335	
e		2.54			0.100	
e3		17.78			0.700	
F			7.1			0.280
i			5.1			0.201
L		3.3			0.130	
Z			1.27			0.050

DIP16.TBL

Information furnished is believed to be accurate and reliable. However, SGS-THOMSON Microelectronics assumes no responsibility for the consequences of use of such information nor for any infringement of patents or other rights of third parties which may result from its use. No licence is granted by implication or otherwise under any patent or patent rights of SGS-THOMSON Microelectronics. Specifications mentioned in this publication are subject to change without notice. This publication supersedes and replaces all information previously supplied. SGS-THOMSON Microelectronics products are not authorized for use as critical components in life support devices or systems without express written approval of SGS-THOMSON Microelectronics.

© 1994 SGS-THOMSON Microelectronics - All Rights Reserved

Purchase of I²C Components of SGS-THOMSON Microelectronics, conveys a license under the Philips I²C Patent. Rights to use these components in a I²C system, is granted provided that the system conforms to the I²C Standard Specifications as defined by Philips.

SGS-THOMSON Microelectronics GROUP OF COMPANIES

Australia - Brazil - China - France - Germany - Hong Kong - Italy - Japan - Korea - Malaysia - Malta - Morocco
The Netherlands - Singapore - Spain - Sweden - Switzerland - Taiwan - Thailand - United Kingdom - U.S.A.