

54F/74F257A Quad 2-Input Multiplexer with TRI-STATE® Outputs

General Description

The 'F257A is a quad 2-input multiplexer with TRI-STATE outputs. Four bits of data from two sources can be selected using a Common Data Select input. The four outputs present the selected data in true (non-inverted) form. The outputs may be switched to a high impedance state with a HIGH on the common Output Enable (OE) input, allowing the outputs to interface directly with bus-oriented systems.

Features

- Multiplexer expansion by tying outputs together
- Non-inverting TRI-STATE outputs
- Input clamp diodes limit high-speed termination effects
- Guaranteed 4000V minimum ESD protection

Commercial	Military	Package Number	Package Description
74F257APC		N16E	16-Lead (0.300" Wide) Molded Dual-In-Line
	54F257ADM (Note 2)	J16A	16-Lead Ceramic Dual-In-Line
74F257ASC (Note 1)		M16A	16-Lead (0.150" Wide) Molded Small Outline, JEDEC
74F257ASJ (Note 1)		M16D	16-Lead (0.300" Wide) Molded Small Outline, EIAJ
	54F257AFM (Note 2)	W16A	16-Lead Cerpack
	54F257ALL (Note 2)	E20A	20-Lead Ceramic Leadless Chip Carrier, Type C

Note 1: Devices also available in 13" reel. Use suffix = SCX and SJX.

Note 2: Military grade device with environmental and burn-in processing. Use suffix = DMQB, FMQB and LMQB.

Logic Symbols

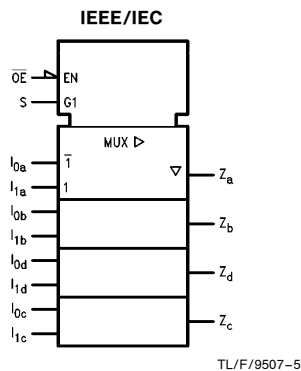
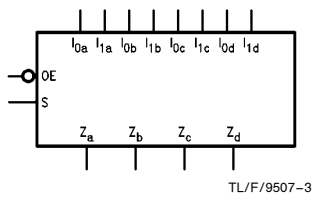

Connection Diagrams

Pin Assignment for DIP, SOIC and Flatpak

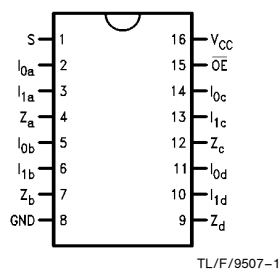

Pin Assignment for LCC

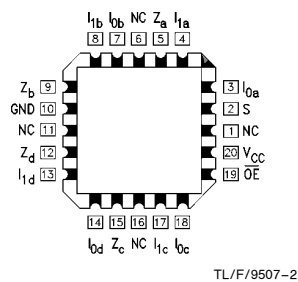

TRI-STATE® is a registered trademark of National Semiconductor Corporation.

Unit Loading/Fan Out

Pin Names	Description	54F/74F	
		U.L. HIGH/LOW	Input I_{IH}/I_{IL} Output I_{OH}/I_{OL}
S	Common Data Select Input	1.0/1.0	20 μ A/ -0.6 mA
\overline{OE}	TRI-STATE Output Enable Input (Active LOW)	1.0/1.0	20 μ A/ -0.6 mA
$I_{0a}-I_{0d}$	Data Inputs from Source 0	1.0/1.0	20 μ A/ -0.6 mA
$I_{1a}-I_{1d}$	Data Inputs from Source 1	1.0/1.0	20 μ A/ -0.6 mA
Z_a-Z_d	TRI-STATE Multiplexer Outputs	150/40 (33.3)	-3 mA/24 mA (20 mA)

Functional Description

The 'F257A is a quad 2-input multiplexer with TRI-STATE outputs. It selects four bits of data from two sources under control of a Common Data Select input. When the Select input is LOW, the I_{0x} inputs are selected and when Select is HIGH, the I_{1x} inputs are selected. The data on the selected inputs appears at the outputs in true (non-inverted) form. The device is the logic implementation of a 4-pole, 2-position switch where the position of the switch is determined by the logic levels supplied to the Select input. The logic equation for the outputs is shown below:

$$Z_n = \overline{OE} \cdot (I_n \cdot S + I_{0n} \cdot \overline{S})$$

When the Output Enable input (\overline{OE}) is HIGH, the outputs are forced to a high impedance OFF state. If the outputs are tied together, all but one device must be in the high impedance state to avoid high currents that would exceed the maximum ratings. Designers should ensure the Output Enable signals to TRI-STATE devices whose outputs are tied together are designed so there is no overlap.

Truth Table

Output Enable	Select Input	Data Inputs		Output
\overline{OE}	S	I_0	I_1	Z
H	X	X	X	Z
L	H	X	L	L
L	H	X	H	H
L	L	L	X	L
L	L	H	X	H

H = HIGH Voltage Level
L = LOW Voltage Level
X = Immaterial
Z = High Impedance

Logic Diagram

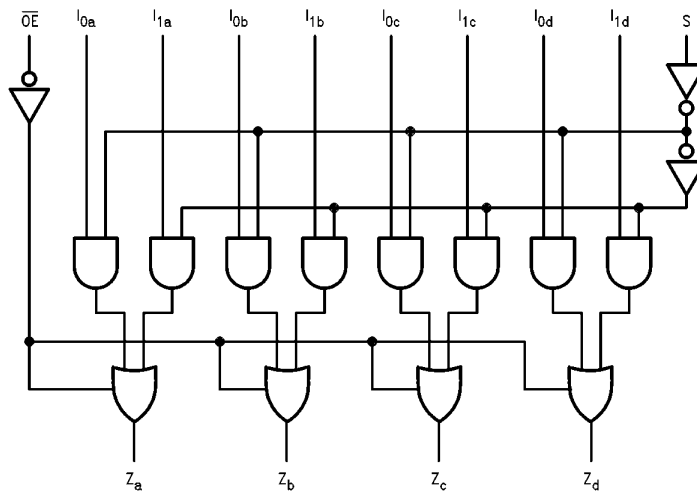

TL/F/9507-4

Please note that this diagram is provided only for the understanding of logic operations and should not be used to estimate propagation delays.

Absolute Maximum Ratings (Note 1)

If Military/Aerospace specified devices are required, please contact the National Semiconductor Sales Office/Distributors for availability and specifications.

Storage Temperature	-65°C to +150°C
Ambient Temperature under Bias	-55°C to +125°C
Junction Temperature under Bias	-55°C to +175°C
Plastic	-55°C to +150°C
V _{CC} Pin Potential to Ground Pin	-0.5V to +7.0V
Input Voltage (Note 2)	-0.5V to +7.0V
Input Current (Note 2)	-30 mA to +5.0 mA
Voltage Applied to Output in HIGH State (with V _{CC} = 0V)	
Standard Output	-0.5V to V _{CC}
TRI-STATE Output	-0.5V to +5.5V

Current Applied to Output in LOW State (Max) twice the rated I_{OL} (mA)

ESD Last Passing Voltage (Min) 4000V

Note 1: Absolute maximum ratings are values beyond which the device may be damaged or have its useful life impaired. Functional operation under these conditions is not implied.

Note 2: Either voltage limit or current limit is sufficient to protect inputs.

Recommended Operating Conditions

Free Air Ambient Temperature	
Military	-55°C to +125°C
Commercial	0°C to +70°C
Supply Voltage	
Military	+4.5V to +5.5V
Commercial	+4.5V to +5.5V

DC Electrical Characteristics

Symbol	Parameter		54F/74F			Units	V _{CC}	Conditions
			Min	Typ	Max			
V _{IH}	Input HIGH Voltage		2.0			V		Recognized as a HIGH Signal
V _{IL}	Input LOW Voltage		0.8			V		Recognized as a LOW Signal
V _{CD}	Input Clamp Diode Voltage		-1.2			V	Min	I _{IN} = -18 mA
V _{OH}	Output HIGH Voltage	54F 10% V _{CC} 54F 10% V _{CC} 74F 10% V _{CC} 74F 10% V _{CC} 74F 5% V _{CC} 74F 5% V _{CC}	2.5 2.4 2.5 2.4 2.7 2.7			V	Min	I _{OH} = -1 mA I _{OH} = -3 mA I _{OH} = -1 mA I _{OH} = -3 mA I _{OH} = -1 mA I _{OH} = -3 mA
V _{OL}	Output LOW Voltage	54F 10% V _{CC} 74F 10% V _{CC}	0.5 0.5			V	Min	I _{OL} = 20 mA I _{OL} = 24 mA
I _{IH}	Input HIGH Current	54F 74F	20.0 5.0			μA	Max	V _{IN} = 2.7V
I _{BVI}	Input HIGH Current Breakdown Test	54F 74F	100 7.0			μA	Max	V _{IN} = 7.0V
I _{CEX}	Output HIGH Leakage Current	54F 74F	250 50			μA	Max	V _{OUT} = V _{CC}
V _{ID}	Input Leakage Test	74F	4.75			V	0.0	I _{ID} = 1.9 μA All Other Pins Grounded
I _{OD}	Output Leakage Circuit Current	74F	3.75			μA	0.0	V _{IOD} = 150 mV All Other Pins Grounded
I _{IL}	Input LOW Current		-0.6			mA	Max	V _{IN} = 0.5V
I _{OZH}	Output Leakage Current		50			μA	Max	V _{OUT} = 2.7V
I _{OZL}	Output Leakage Current		-50			μA	Max	V _{OUT} = 0.5V
I _{OS}	Output Short-Circuit Current		-60			mA	Max	V _{OUT} = 0V
I _{ZZ}	Bus Drainage Test		500			μA	0.0V	V _{OUT} = 5.25V
I _{CCH}	Power Supply Current		9.0			mA	Max	V _O = HIGH
I _{CCL}	Power Supply Current		14.5			mA	Max	V _O = LOW
I _{CCZ}	Power Supply Current		15			mA	Max	V _O = HIGH Z

AC Electrical Characteristics

Symbol	Parameter	74F			54F		74F		Units
		T _A = +25°C V _{CC} = +5.0V C _L = 50 pF			T _A , V _{CC} = Mil C _L = 50 pF		T _A , V _{CC} = Com C _L = 50 pF		
		Min	Typ	Max	Min	Max	Min	Max	
t _{PLH} t _{PHL}	Propagation Delay I _n to Z _n	2.5 2.0	4.5 4.2	5.5 5.5	2.0 1.5	7.0 7.0	2.0 2.0	6.0 6.0	ns
t _{PLH} t _{PHL}	Propagation Delay S to Z _n	4.0 2.5	5.0 6.5	9.5 7.0	3.5 2.5	11.5 9.0	3.5 2.5	10.5 8.0	ns
t _{PZH} t _{PZL}	Output Enable Time	2.0 2.5	5.9 5.5	6.0 7.0	2.0 2.5	8.0 9.0	2.0 2.5	7.0 8.0	ns
t _{PHZ} t _{PLZ}	Output Disable Time	2.0 2.0	4.3 4.5	6.0 6.0	2.0 2.0	7.0 8.5	2.0 2.0	7.0 7.0	ns

Ordering Information

The device number is used to form part of a simplified purchasing code where the package type and temperature range are defined as follows:

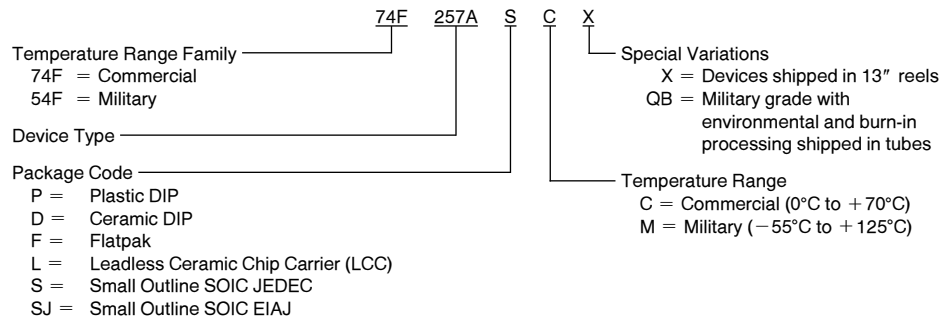

Physical Dimensions inches (millimeters)

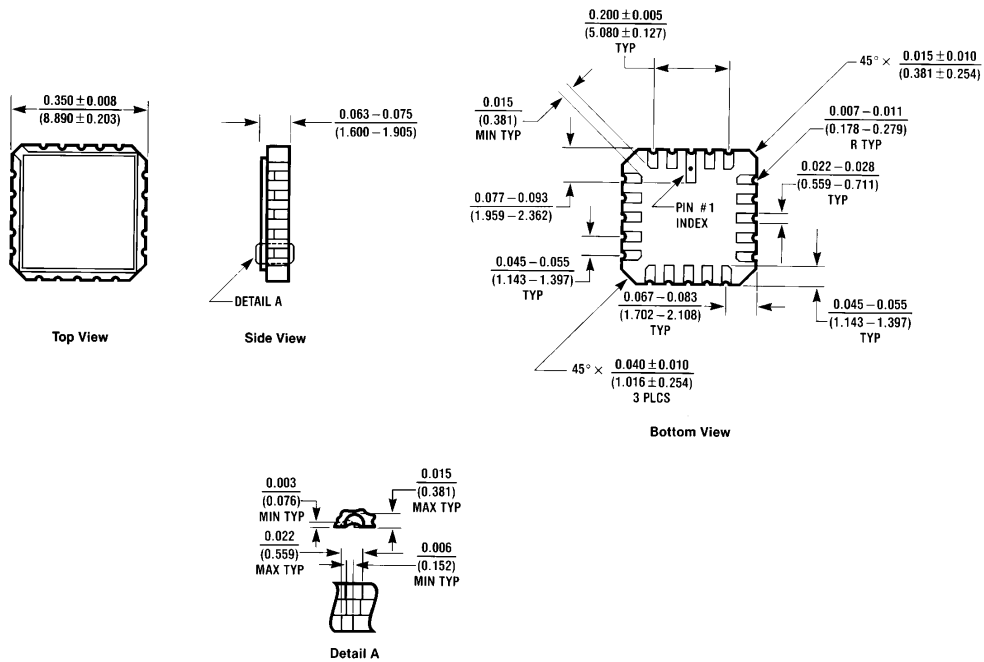

E20A (REV D)

**20-Lead Ceramic Leadless Chip Carrier (L)
 NS Package Number E20A**

Physical Dimensions inches (millimeters) (Continued)

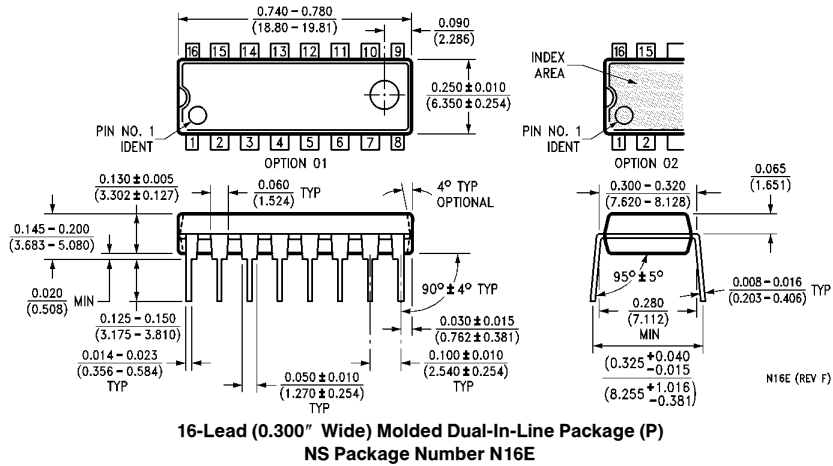
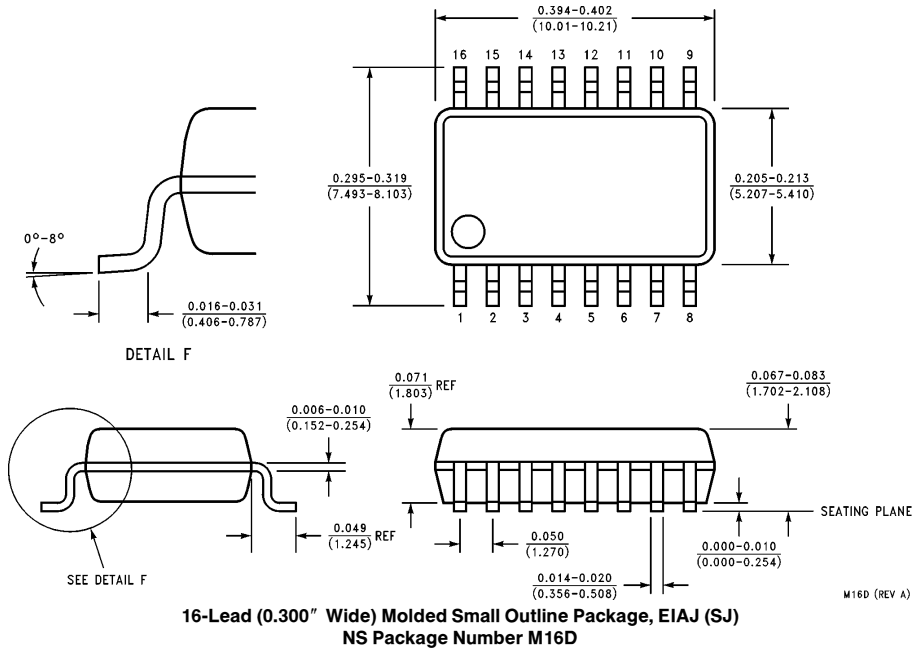

Physical Dimensions inches (millimeters) (Continued)

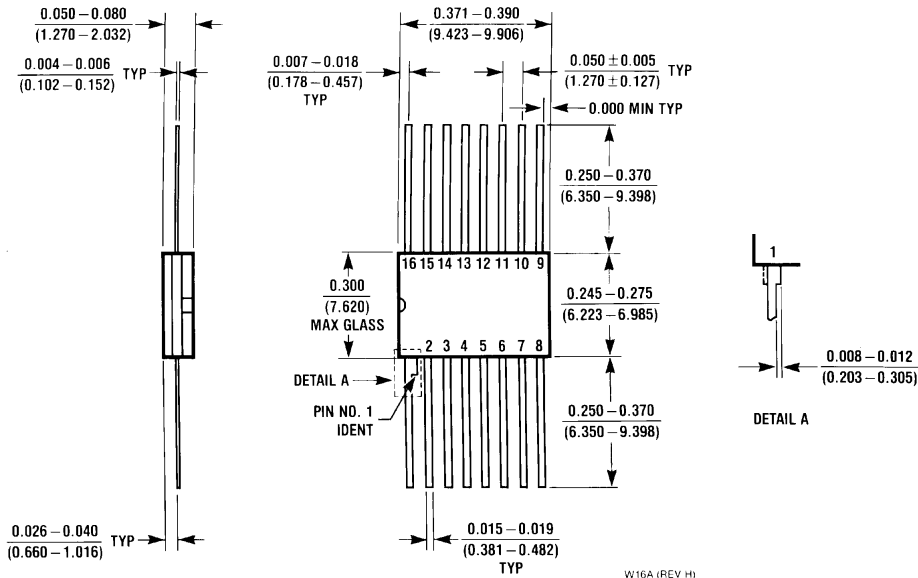

**16-Lead Ceramic Flatpak (F)
NS Package Number W16A**

W16A (REV H)

LIFE SUPPORT POLICY

NATIONAL'S PRODUCTS ARE NOT AUTHORIZED FOR USE AS CRITICAL COMPONENTS IN LIFE SUPPORT DEVICES OR SYSTEMS WITHOUT THE EXPRESS WRITTEN APPROVAL OF THE PRESIDENT OF NATIONAL SEMICONDUCTOR CORPORATION. As used herein:

1. Life support devices or systems are devices or systems which, (a) are intended for surgical implant into the body, or (b) support or sustain life, and whose failure to perform, when properly used in accordance with instructions for use provided in the labeling, can be reasonably expected to result in a significant injury to the user.
2. A critical component is any component of a life support device or system whose failure to perform can be reasonably expected to cause the failure of the life support device or system, or to affect its safety or effectiveness.



National Semiconductor Corporation
2900 Semiconductor Drive
P.O. Box 58090
Santa Clara, CA 95052-8090
Tel: (1800) 272-9959
TWX: (910) 339-9240

National Semiconductor GmbH
Livny-Gargan-Str. 10
D-82256 Fürstenfeldbruck
Germany
Tel: (81-41) 35-0
Telex: 527849
Fax: (81-41) 35-1

National Semiconductor Japan Ltd.
Sumitomo Chemical
Engineering Center
Bldg. 7F
1-7-1, Nakase, Mihama-Ku
Chiba-City,
Ciba Prefecture 261
Tel: (043) 299-2300
Fax: (043) 299-2500

National Semiconductor Hong Kong Ltd.
13th Floor, Straight Block,
Ocean Centre, 5 Canton Rd.
Tsimshatsui, Kowloon
Hong Kong
Tel: (852) 2737-1600
Fax: (852) 2736-9960

National Semicondutores Do Brazil Ltda.
Rue Deputado Lacorda Franco
120-3A
Sao Paulo-SP
Brazil 05418-000
Tel: (55-11) 212-5066
Telex: 391-1131931 NSBR BR
Fax: (55-11) 212-1181

National Semiconductor (Australia) Pty. Ltd.
Building 16
Business Park Drive
Monash Business Park
Nottingham, Melbourne
Victoria 3168 Australia
Tel: (3) 558-9999
Fax: (3) 558-9998

National does not assume any responsibility for use of any circuitry described, no circuit patent licenses are implied and National reserves the right at any time without notice to change said circuitry and specifications.

National Semiconductor was acquired by Texas Instruments.

http://www.ti.com/corp/docs/investor_relations/pr_09_23_2011_national_semiconductor.html

This file is the datasheet for the following electronic components:

54F257ALMQB - <http://www.ti.com/product/54f257almqb?HQS=TI-null-null-dscatalog-df-pf-null-wwe>

54F257AFMQB - <http://www.ti.com/product/54f257afmqb?HQS=TI-null-null-dscatalog-df-pf-null-wwe>

54F257ADMQB - <http://www.ti.com/product/54f257admqb?HQS=TI-null-null-dscatalog-df-pf-null-wwe>



LittleDiode supplies new, hard to find or obsolete electronic components and semiconductors all over the world.

With over two million different components listed you are sure to find the part you need.

Feel free to visit us today at our online store:

LittleDiode.com

Looking forward to providing you with the best possible service.