

FEATURES

12-Bit CMOS DAC with Output Amplifier and Reference

Parallel Loading Structure: AD7245

(8 + 4) Loading Structure: AD7248

Single or Dual Supply Operation

Fast Digital Interface (80ns \overline{WR} Pulse)

Low Power (65mW typ)

0.3", Skinny, 20- and 24-Pin DIP

20- and 28-Terminal Surface Mount Packages

NOTE: AD7245A/AD7248A IS RECOMMENDED FOR NEW DESIGNS

GENERAL DESCRIPTION

The AD7245/AD7248 is a complete 12-bit, voltage-output, digital-to-analog converter with output amplifier and Zener voltage reference on a monolithic CMOS chip. No external trims are required to achieve full specified performance for the part.

The part features double-buffered interface logic with a 12-bit input latch and 12-bit DAC latch. The data held in the DAC latch determines the analog output of the converter. The AD7245 accepts 12-bit parallel data which is latched into the input latch on the rising edge of \overline{CS} or \overline{WR} . The AD7248 has an 8-bit-wide data bus, and data is loaded to the input latch in two write operations, an 8-bit LSB load and a 4-bit MSB load. The input data must be right justified. For both parts, an asynchronous \overline{LDAC} signal transfers data from the input latch to the DAC latch. The AD7245 also has a \overline{CLR} signal on the DAC latch which allows features such as power-on reset to be implemented. All logic inputs are level triggered and are TTL and CMOS (5V) level compatible, while the control logic is 5V compatible with most microprocessors.

The on-chip 5V buried Zener diode provides a low-noise, temperature compensated reference for the DAC. The gain setting resistors allow a number of ranges at the output: 0 to +5V, 0 to +10V when using single supply and 0 to +5V, -5V to +5V when operated in dual supplies. The output amplifier is capable of developing +10V across a 2k Ω load to GND.

The AD7245/AD7248 is fabricated in an all ion-implanted, high-speed linear, compatible CMOS (LC²MOS) process. The AD7245 is packaged in a small, 0.3"-wide, 24-pin DIP and 28-terminal surface mount packages. The AD7248 is available in a 0.3"-wide, 20-pin DIP and 20-terminal surface mount packages.

REV. A

Information furnished by Analog Devices is believed to be accurate and reliable. However, no responsibility is assumed by Analog Devices for its use; nor for any infringements of patents or other rights of third parties which may result from its use. No license is granted by implication or otherwise under any patent or patent rights of Analog Devices.

FUNCTIONAL BLOCK DIAGRAMS

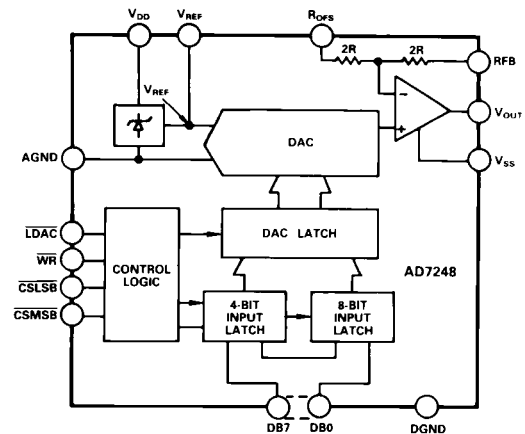
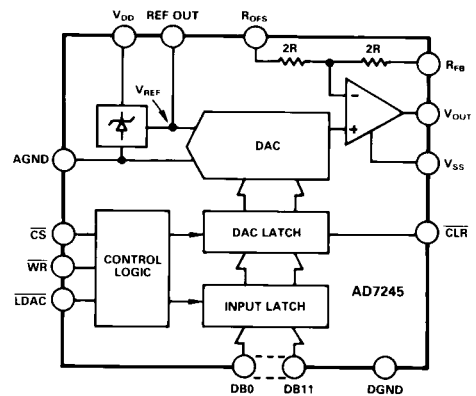

PRODUCT HIGHLIGHTS

1. Complete 12-Bit DACPORT™

The AD7245/AD7248 is a complete, voltage output, 12-bit DAC on one chip. This single-chip design of the DAC reference and output amplifier is inherently more reliable than multichip designs.

2. Microprocessor Compatibility

The parallel loading structure of the AD7245 allows connection to microprocessors with a 16-bit-wide data bus. The AD7248 is aimed at microprocessors which have an 8-bit-wide data bus structure. The high-speed logic of both parts allows direct interfacing to most modern microprocessors. Additionally, the double buffered interface enables simultaneous update of the AD7245/AD7248 in multiple DAC systems.

DACPORT is a trademark of Analog Devices, Inc.

One Technology Way; P. O. Box 9106; Norwood, MA 02062-9106
 Tel: 617/329-4700 TWX: 710/394-6577
 West Coast Central Atlantic
 714/641-9391 214/231-5094 215/643-7790

SPECIFICATIONS

SINGLE SUPPLY ($V_{DD} = +15V \pm 5\%$, $V_{SS} = AGND = DGND = 0V$; $R_L = 2k\Omega$ to GND; $C_L = 100pF$ to GND; REF OUT unloaded) unless otherwise stated. All specifications T_{min} to T_{max} unless otherwise stated.)

Parameter	J, A Version ²	S Version ²	Units	Test Conditions/Comments
STATIC PERFORMANCE				
Resolution	12	12	Bits	
Relative Accuracy	± 1	± 1	LSB max	$V_{DD} = +11.4V$ to $+14.25V$
		± 1.5	LSB max	$V_{DD} = +14.25V$ to $+15.75V$
Differential Nonlinearity ³	± 1	± 1	LSB max	Guaranteed Monotonic
Unipolar Offset Error ³				
at $+25^\circ C$	± 3	± 3	LSB max	
T_{min} to T_{max}	± 5	± 5	LSB max	Typical Tempco is $\pm 3ppm$ of FSR ^{4/°C}
DAC Gain Error ^{3,5}	± 2	± 2	LSB max	
Full-Scale Output Voltage Error ⁶				
$T_A = +25^\circ C$	± 0.2	± 0.2	% of FSR max	$V_{DD} = +15V$ for J, A Grades;
T_{min} to T_{max}		± 0.6	% of FSR max	$V_{DD} = +12V$ & $+15V$ for S Grade
Δ Full Scale/ ΔV_{DD}				$V_{DD} = +12V$ & $+15V$
$T_A = +25^\circ C$	± 0.12	± 0.12	% of FSR/V max	$\Delta V_{DD} = +5\%$
Full-Scale Temperature Coefficient ⁷	± 30		ppm of FSR/°C max	
Δ Offset/ ΔV_{DD}	± 1	± 2	mV max	$\Delta V_{DD} = \pm 5\%$
REFERENCE				
Reference Output (at $+25^\circ C$)	4.99/5.01	4.99/5.01	V min to V max	$V_{DD} = +15V$ for J, A Grades;
				$V_{DD} \pm +12V$ & $+15V$ for S Grade
Δ Reference/ ΔV_{DD}				
$T_A = +25^\circ C$	6	6	mV/V max	$\Delta V_{DD} = \pm 5\%$
Reference Temperature Coefficient	± 30	± 40	ppm of FSR/°C typ	FSR = 5V
Reference Load Sensitivity (Δ Reference/ ΔI)	± 1	± 1.5	mV max	Reference Load Current Change (0-100 μA)
DIGITAL INPUTS				
Input High Voltage, V_{INH}	2.4	2.4	V min	
Input Low Voltage, V_{INL}	0.8	0.8	V max	
Input Current				
I_{IN} (Data Inputs)				$V_{IN} = 0V$ or V_{DD}
at $+25^\circ C$	± 1	± 1	μA max	
T_{min} to T_{max}	± 10	± 10	μA max	
I_{INH} (Control Inputs) ⁸				$V_{IN} = V_{DD}$
at $+25^\circ C$	± 1	± 1	μA max	
T_{min} to T_{max}	± 10	± 10	μA max	
I_{INL} (Control Inputs) ⁸				$V_{IN} = 0V$
at $+25^\circ C$	150	150	μA max	
T_{min} to T_{max}	200	200	μA max	
Input Capacitance ⁹ (AD7245)	8	8	pF max	
Input Capacitance ⁹ (AD7248)	16	16	pF max	
ANALOG OUTPUT				
Output Range Resistors	15/30	15/30	k Ω min/k Ω max	
Ranges	+5, +10	+5, +10	V	Pin Strappable. Min Load Resistance is 2k Ω to GND
dc Output Impedance	0.5	0.5	Ω typ	
Short-Circuit Current	40	40	mA typ	
DYNAMIC PERFORMANCE⁹				
Output Voltage Settling Time				Settling Time to $\pm 1LSB$. $R_L = 5k\Omega$, $C_L = 100pF$
Positive Full-Scale Change	5	8	μs max	DAC Register all 0s to all 1s
Negative Full-Scale Change	10	10	μs typ	DAC Register all 1s to all 0s
Output Voltage Slew Rate	2	1.5	V/ μs min	
Digital Feedthrough ^{3,10}	10	10	nV secs typ	
Digital-to-Analog Glitch Impulse	30	30	nV secs typ	Major Carry Transition
POWER SUPPLIES				
V_{DD} Range	14.25/15.75	11.4/15.75	V min/V max	For Specified Performance
I_{DD}				Output Unloaded
at $+25^\circ C$	9	9	mA max	Typically 4.5mA
T_{min} to T_{max}	12	12	mA max	

NOTES

¹For the S Version only: $V_{DD} = +12V \pm 5\%$ to $+15V \pm 5\%$

²Temperature ranges are as follows:

J Version, 0 to $+70^\circ C$

A Version, $-25^\circ C$ to $+85^\circ C$

S Version, $-55^\circ C$ to $+125^\circ C$.

³See Terminology.

⁴FSR means Full-Scale Range and is 5V with R_{OFS} connected to R_{FB} , V_{OUT} and 10V with R_{OFS} connected to GND and R_{FB} connected to V_{OUT} .

⁵This error is calculated with respect to the reference voltage and is measured after the offset error has been allowed for.

⁶This error is calculated w.r.t. an ideal 4.9988V (on the 5V range) or 9.9976V (on the 10V range).

It includes the effects of internal voltage reference, gain and offset errors.

⁷Full-scale T.C. = $\Delta FSR/\Delta T$, where ΔFSR is the full-scale change from $T_A = +25^\circ C$ to T_{min} or T_{max} .

⁸Control inputs are CS, \overline{WR} , LDAC and CLR for AD7245 and CSMSB, CSLSB, \overline{WR} and LDAC for AD7248.

⁹Sample tested at $+25^\circ C$ to ensure compliance.

¹⁰The metal lid on the AD7245 (only) ceramic (D-24A) package is connected to Pin 12 (DGND).

Specifications subject to change without notice.

SPECIFICATIONS

DUAL SUPPLY ($V_{DD} = +15V \pm 5\%$, $V_{SS} = -15V \pm 5\%$, $AGND = DGND = 0V$; $R_L = 2k\Omega$ to GND; $C_L = 100pF$ to GND; REF OUT unloaded unless otherwise stated. All specifications T_{min} to T_{max} unless otherwise stated.)

Parameter	J, A Version ²	S Version ²	Units	Test Conditions/Comments
STATIC PERFORMANCE				
Resolution	12	12	Bits	
Relative Accuracy ³	± 1		LSB max	$V_{DD}/V_{SS} = \pm 11.4V$ to $\pm 14.25V$
		± 1	LSB max	$V_{DD}/V_{SS} = \pm 14.25V$ to $\pm 15.75V$
		± 1.5	LSB max	Guaranteed Monotonic
Differential Nonlinearity ³	± 1	± 1	LSB max	R_{OFS} Connected to REF OUT
Bipolar Zero Offset Error ³				
at $+25^\circ C$	± 3	± 3	LSB max	
T_{min} to T_{max}	± 5	± 5	LSB max	Typical Tempco is $\pm 3ppm$ of FSR ^{4/°C}
DAC Gain Error ^{3,5}	± 2	± 2	LSB max	
Full-Scale Output Voltage Error ⁶				
$T_A = +25^\circ C$	± 0.2	± 0.2	% of FSR max	$V_{DD}/V_{SS} = \pm 15V$ for J, A Grades;
T_{min} to T_{max}		± 0.6	% of FSR max	$V_{DD}/V_{SS} = \pm 12V$ & $\pm 15V$ for S Grade
Δ Full Scale/ ΔV_{DD}				$V_{DD}/V_{SS} = \pm 12V$ & $\pm 15V$
$T_A = +25^\circ C$	± 0.12	± 0.12	% of FSR/V max	$\Delta V_{DD} = \pm 5\%$
Δ Full Scale/ ΔV_{SS}				
$T_A = +25^\circ C$	± 0.01	± 0.01	% of FSR/V max	$\Delta V_{SS} = \pm 5\%$
Full-Scale Temperature Coefficient ⁷	± 30		ppm of FSR/ $^\circ C$ max	
Δ Offset/ ΔV_{DD}	± 1	± 2	mV max	$\Delta V_{DD} = \pm 5\%$
Δ Offset/ ΔV_{SS}	± 1	± 1	mV max	$\Delta V_{SS} = \pm 5\%$
REFERENCE				
Reference Output (at $+25^\circ C$)	4.99/5.01	4.99/5.01	V min to V max	$V_{DD}/V_{SS} = \pm 15V$ for J, A Grades;
				$V_{DD}/V_{SS} = \pm 12V$ & $\pm 15V$ for S Grade
Δ Reference/ ΔV_{DD}				
$T_A = +25^\circ C$	6	6	mV/V max	$\Delta V_{DD} = \pm 5\%$
Reference Temperature Coefficient	± 30	± 40	ppm of FSR/ $^\circ C$ typ	FSR = 5V
Reference Load Sensitivity (Δ Reference/ ΔI)	± 1	± 1.5	mV max	Reference Load Current Change (0-100 μA) (Not Including R_{OFS} Current)
DIGITAL INPUTS				
Input High Voltage, V_{INH}	2.4	2.4	V min	
Input Low Voltage, V_{INL}	0.8	0.8	V max	
Input Current				$V_{IN} = 0V$ or V_{DD}
I_{IN} (Data Inputs)				
at $+25^\circ C$	± 1	± 1	μA max	
T_{min} to T_{max}	± 10	± 10	μA max	$V_{IN} = V_{DD}$
I_{INH} (Control Inputs) ⁸				
at $+25^\circ C$	± 1	± 1	μA max	
T_{min} to T_{max}	± 10	± 10	μA max	$V_{IN} = 0V$
I_{INL} (Control Inputs) ⁸				
at $+25^\circ C$	150	150	μA max	
T_{min} to T_{max}	200	200	μA max	
Input Capacitance ⁹ (AD7245)	8	8	pF max	
Input Capacitance ⁹ (AD7248)	16	16	pF max	
ANALOG OUTPUT				
Output Range Resistors	15/30	15/30	k Ω min/k Ω max	
Ranges	$\pm 5, +5$	$\pm 5, +5$	V	Pin Strappable. Min Load Resistance is 2k Ω to GND
dc Output Impedance	0.5	0.5	Ω typ	
Short-Circuit Current	40	40	mA typ	
DYNAMIC PERFORMANCE⁹				
Output Voltage Settling Time				Settling Time to $\pm 1LSB$. $R_L = 5k\Omega$, $C_L = 100pF$
Positive Full-Scale Change	5	10	μs max	DAC Register all 0s to all 1s
Negative Full-Scale Change	10	10	μs max	DAC Register all 1s to all 0s
Output Voltage Slew Rate	2	1.5	V/ μs min	
Digital Feedthrough ^{3,10}	10	10	nV secs typ	
Digital-to-Analog Glitch Impulse	30	30	nV secs typ	Major Carry Transition
POWER SUPPLIES				
V_{DD} Range	14.25/15.75	11.4/15.75	V min/V max	For Specified Performance
V_{SS} Range	-14.25/-15.75	-11.4/-15.75	V min/V max	For Specified Performance
I_{DD}				Output Unloaded
at $+25^\circ C$	9	9	mA max	Typically 5mA
T_{min} to T_{max}	12	12	mA max	
I_{SS}				Output Unloaded
at $+25^\circ C$	3	3	mA max	Typically 2mA
T_{min} to T_{max}	5	5	mA max	

NOTES

- ¹For the S Version only: $V_{DD} = +12V \pm 5\%$ to $+15V \pm 5\%$; $V_{SS} = -12V \pm 5\%$ to $-15V \pm 5\%$.
- ²Temperature ranges are as follows:
 J Version, 0 to +70°C
 A Version, -25°C to +85°C
 S Version, -55°C to +125°C.
- ³See Terminology.
- ⁴FSR means Full-Scale Range and is 5V with R_{OFFS} connected to R_{FB} , V_{OUT} and 10V with R_{OFFS} connected to GND and R_{FB} connected to V_{OUT} .
- ⁵This error is calculated with respect to the reference voltage and is measured after the offset error has been allowed for.
- ⁶This error is calculated w.r.t. an ideal 4.9988V (on the 5V range) or 9.9976V (on the 10V range).
 It includes the effects of internal voltage reference, gain and offset errors.
- ⁷Full-scale T.C. = $\Delta FS/\Delta T$, where ΔFS is the full-scale change from $T_A = +25^\circ C$ to T_{min} or T_{max} .
- ⁸Control inputs are CS, WR, LDAC and CLR for AD7245 and CSMSB, CSLSB, WR and LDAC for AD7248.
- ⁹Sample tested at +25°C to ensure compliance.
- ¹⁰The metal lid on the AD7245 (only) ceramic (D-24A) package is connected to Pin 12 (DGND).

Specifications subject to change without notice.

SWITCHING CHARACTERISTICS¹ ($V_{DD} = +15V \pm 5\%$; $V_{SS} = 0V$ or $-15V \pm 5\%$; See Figures 5 and 7)

Parameter	J Grade	A Grade	S Grade	Units	Conditions
t_1 ($a + 25^\circ C$ T_{min} to T_{max})	80 100	80 100	105 135	ns min ns min	Chip Select Pulse Width
t_2 ($a + 25^\circ C$ T_{min} to T_{max})	80 100	80 100	105 135	ns min ns min	Write Pulse Width
t_3 ($a + 25^\circ C$ T_{min} to T_{max})	0 0	0 0	0 0	ns min ns min	Chip Select to Write Setup Time
t_4 ($a + 25^\circ C$ T_{min} to T_{max})	0 0	0 0	0 0	ns min ns min	Chip Select to Write Hold Time
t_5 (AD7245 Only) ($a + 25^\circ C$ T_{min} to T_{max})	100 110	100 130	155 250	ns min ns min	Data Valid to Write Setup Time
t_5 (AD7248 Only) ($a + 25^\circ C$ T_{min} to T_{max})	110 130	110 130	180 270	ns min ns min	Data Valid to Write Setup Time
t_6 ($a + 25^\circ C$ T_{min} to T_{max})	10 10	10 10	10 10	ns min ns min	Data Valid to Write Hold Time
t_7 ($a + 25^\circ C$ T_{min} to T_{max})	80 100	80 100	90 120	ns min ns min	Load DAC Pulse Width
t_8 (AD7245 Only) ($a + 25^\circ C$ T_{min} to T_{max})	80 100	80 100	140 200	ns min ns min	Clear Pulse Width

NOTE

- ¹Sample tested at +25°C to ensure compliance.
 - ²For the S Version only: $V_{DD} = +12V \pm 5\%$ to $+15V \pm 5\%$; $V_{SS} = 0V$ or $-12V \pm 5\%$ to $-15V \pm 5\%$.
- Specifications subject to change without notice.

ABSOLUTE MAXIMUM RATINGS*

V_{DD} to AGND	-0.3V, +17V
V_{DD} to DGND	-0.3V, +17V
V_{DD} to V_{SS}	-0.3V, +34V
AGND to DGND	-0.3V, V_{DD}
Digital Input Voltage to DGND	-0.3V, $V_{DD} + 0.3V$
V_{OUT} to AGND ¹	V_{SS} , V_{DD}
V_{OUT} to V_{SS} ¹	0V, +24V
V_{OUT} to V_{DD} ¹	-32V, 0V
REF OUT ¹ to AGND	0V, V_{DD}
Power Dissipation (Any Package) to +75°C	450mW
Derates above 75°C by	6mW/°C
Operating Temperature	
Commercial	0 to +70°C

Industrial	-25°C to +85°C
Extended	-55°C to +125°C
Storage Temperature	-65°C to +150°C
Lead Temperature (Soldering, 10secs)	+300°C

NOTE

¹The output may be shorted to voltages in this range provided the power dissipation of the package is not exceeded.

*Stresses above those listed under "Absolute Maximum Ratings" may cause permanent damage to the device. This is a stress rating only and functional operation of the device at these or any other conditions above those indicated in the operational sections of this specification is not implied. Exposure to absolute maximum rating conditions for extended periods may affect device reliability.

CAUTION

ESD (electrostatic-discharge) sensitive device. The digital control inputs are diode protected; however, permanent damage may occur on unconnected devices subject to high energy electrostatic fields. Unused devices must be stored in conductive foam or shunts. The protective foam should be discharged to the destination socket before devices are removed.



TERMINOLOGY

RELATIVE ACCURACY

Relative Accuracy, or end-point nonlinearity, is a measure of the actual deviation from a straight line passing through the end-points of the DAC transfer function. It is measured after allowing for zero and full scale and is normally expressed in LSBs or as a percentage of full-scale reading.

DIFFERENTIAL NONLINEARITY

Differential Nonlinearity is the difference between the measured change and the ideal 1LSB change between any two adjacent codes. A specified differential nonlinearity of ± 1 LSB max over the operating temperature range ensures monotonicity.

DIGITAL FEEDTHROUGH

Digital Feedthrough is the glitch impulse injected from the digital inputs to the analog output when the inputs change state. It is measured with LDAC high and is specified in nV secs.

DAC GAIN ERROR

DAC Gain Error is a measure of the output error between an ideal DAC and the actual device output with all 1s loaded after offset error has been allowed for. It is therefore defined as:

$$\text{Measured Value} - \text{Offset} - \text{Ideal Value}$$

where the ideal value is calculated relative to the actual reference value.

UNIPOLAR OFFSET ERROR

Unipolar Offset Error is a combination of the offset errors of the voltage-mode DAC and the output amplifier and is measured when the part is configured for unipolar outputs. It is present for all codes and is measured with all 0s in the DAC register.

BIPOLAR ZERO OFFSET ERROR

Bipolar Zero Offset Error is measured when the part is configured for bipolar output and is a combination of errors from the DAC and output amplifier. It is present for all codes and is measured with a code of 2048 (decimal) in the DAC register.

AD7245 PIN FUNCTION DESCRIPTION (DIP PIN NUMBERS)

Pin	Mnemonic	Description	Pin	Mnemonic	Description
1	V _{SS}	Negative Supply Voltage (0V for single supply operation).	18	$\overline{\text{CS}}$	Chip Select Input (Active LOW). The device is selected when this input is active.
2	R _{OFs}	Bipolar Offset Resistor. This provides access to the on-chip application resistors and allows different output voltage ranges.	19	$\overline{\text{WR}}$	Write Input (Active LOW). This is used in conjunction with $\overline{\text{CS}}$ to write data into the input latch of the AD7245.
3	REF OUT	Reference Output. The on-chip reference is provided at this pin and is used when configuring the part for bipolar outputs.	20	$\overline{\text{LDAC}}$	Load DAC Input (Active LOW). This is an asynchronous input which when active transfers data from the input latch to the DAC latch.
4	AGND	Analog Ground.	21	$\overline{\text{CLR}}$	Clear Input (Active LOW). When this input is active the contents of the DAC latch are reset to all 0s.
5	DB11	Data Bit 11. Most Significant Bit (MSB).	22	V _{DD}	Positive Supply Voltage.
6–11	DB10–DB5	Data Bit 10 to Data Bit 5.	23	R _{FB}	Feedback Resistor. This allows access to the amplifier's feedback loop.
12	DGND	Digital Ground.	24	V _{OUT}	Output Voltage. Three different output voltage ranges can be chosen: 0 to +5V, 0 to +10V or –5V to +5V.
13–16	DB4–DB1	Data Bit 4 to Data Bit 1.			
17	DB0	Data Bit 0. Least Significant Bit (LSB).			

AD7245 PIN CONFIGURATIONS

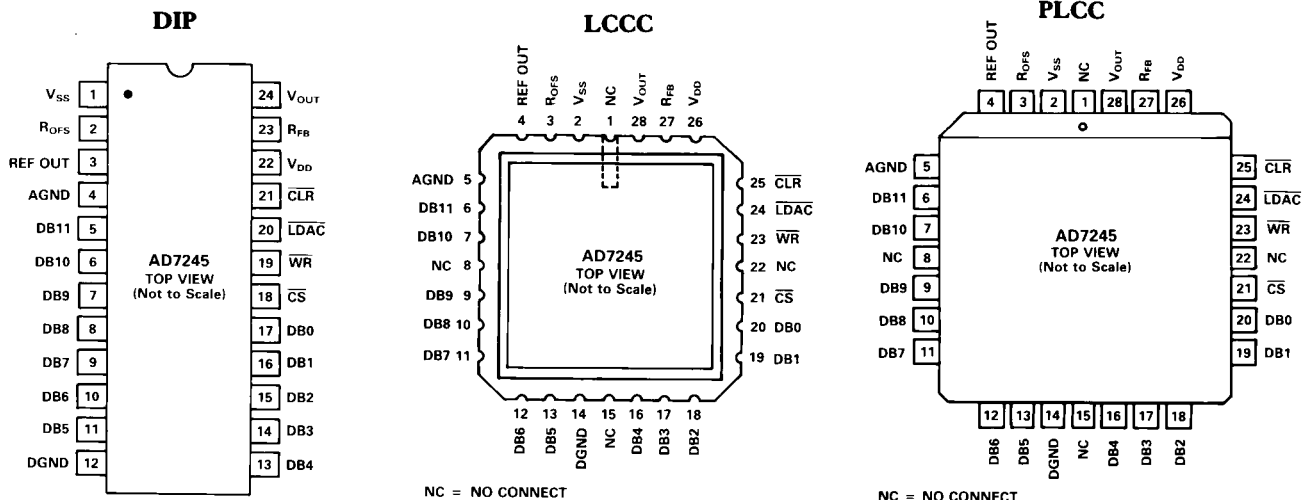

AD7248 PIN FUNCTION DESCRIPTION (ANY PACKAGE)

Pin	Mnemonic	Description	Pin	Mnemonic	Description
1	V _{SS}	Negative Supply Voltage (0V for single supply operation).	14	$\overline{\text{CSMSB}}$	Chip Select Input for MS Nibble. (Active LOW). This selects the upper 4 bits of the input latch. Input data is right-justified.
2	R _{OFS}	Bipolar Offset Resistor. This provides access to the on-chip application resistors and allows different output voltage ranges.	15	$\overline{\text{CSLSB}}$	Chip Select Input for LS byte. (Active LOW). This selects the lower 8 bits of the input latch.
3	REF OUT	Reference Output. The on-chip reference is provided at this pin and is used when configuring the part for bipolar outputs.	16	$\overline{\text{WR}}$	Write Input. This is used in conjunction with $\overline{\text{CSMSB}}$ and $\overline{\text{CSLSB}}$ to load data into the input latch of the AD7248.
4	AGND	Analog Ground.	17	$\overline{\text{LDAC}}$	Load DAC Input (Active LOW). This is an asynchronous input which when active transfers data from the input latch to the DAC latch.
5	DB7	Data Bit 7.	18	V _{DD}	Positive Supply Voltage.
6	DB6	Data Bit 6.	19	R _{FB}	Feedback Resistor. This allows access to the amplifier's feedback loop.
7	DB5	Data Bit 5.	20	V _{OUT}	Output Voltage. Three different output voltage ranges can be chosen: 0 to +5V, 0 to +10V or -5V to +5V.
8	DB4	Data Bit 4.			
9	DB3	Data Bit 3/Data Bit 11 (MSB).			
10	DGND	Digital Ground.			
11	DB2	Data Bit 2/Data Bit 10.			
12	DB1	Data Bit 1/Data Bit 9.			
13	DB0	Data Bit 0 (LSB)/Data Bit 8.			

AD7248 PIN CONFIGURATIONS

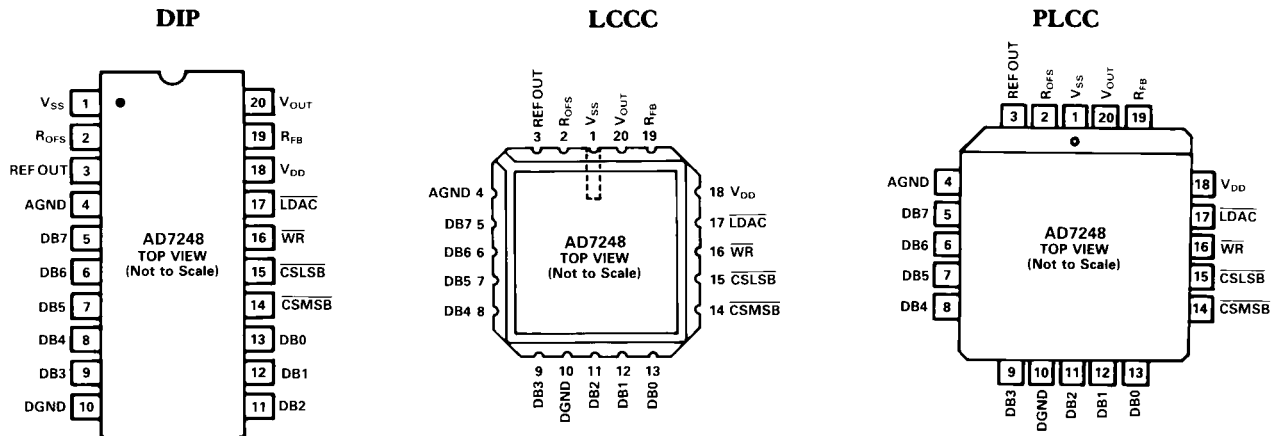

SINGLE SUPPLY LINEARITY AND GAIN ERROR

The output amplifier of the AD7245/AD7248 can have a true negative offset even when the part is operated from a single positive power supply. However, because the lower supply rail to the part is 0V, the output voltage cannot actually go negative. Instead the output voltage sits on the lower rail and this results in the transfer function shown across. This is an offset effect and the transfer function would have followed the dotted line if the output voltage could have gone negative. Normally, linearity is measured after offset and full scale have been adjusted or allowed for. On the AD7245/AD7248 the negative offset is allowed for by calculating the linearity from the code which the amplifier comes off the lower rail. This code is given by the negative offset specification. For example, the single supply linearity specification applies between Code 3 and Code 4095 for the 25°C specification and between Code 5 and Code 4095 over the T_{min} to T_{max} temperature range. Since gain error is also

measured after offset has been allowed for, it is calculated between the same codes as the linearity error. Bipolar linearity and gain error are measured between Code 0 and Code 4095.

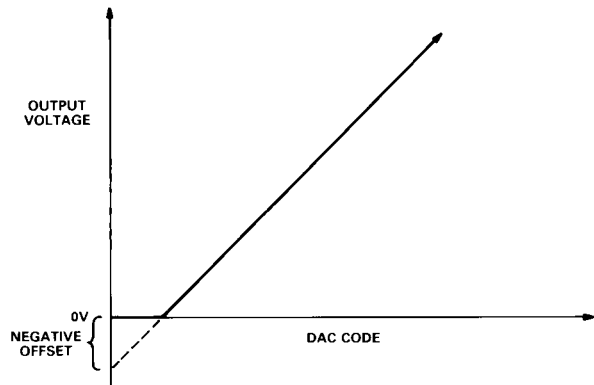

Typical Performance—AD7245/AD7248

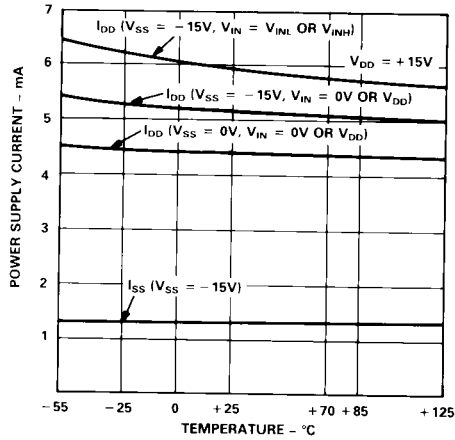

Power Supply Current vs. Temperature

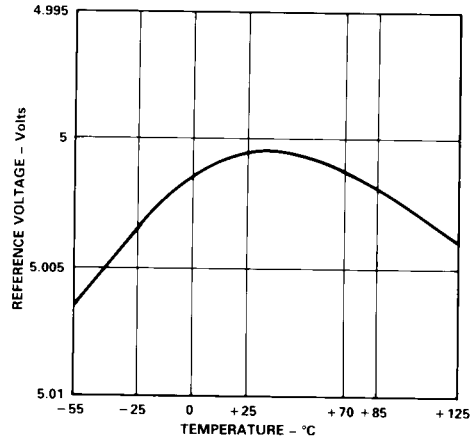

Reference Voltage vs. Temperature

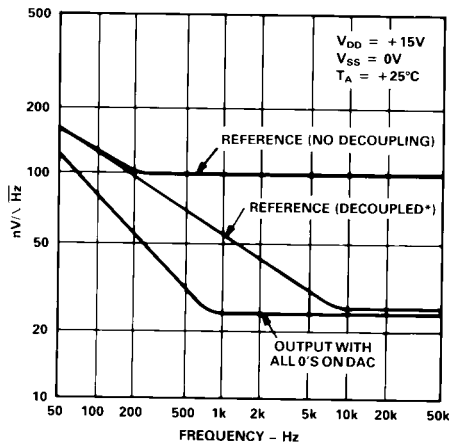

*REFERENCE DECOUPLING COMPONENTS AS PER FIGURE 8

Noise Spectral Density vs. Frequency

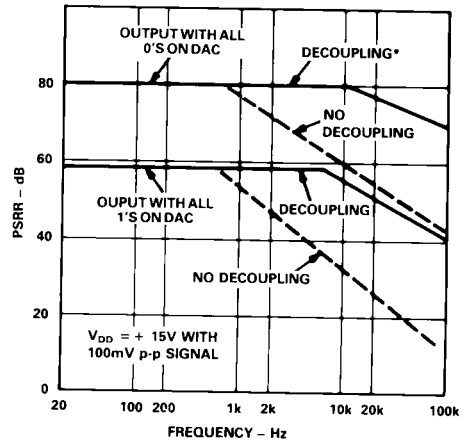

*POWER SUPPLY DECOUPLING CAPACITORS ARE 10 μ F AND 0.1 μ F

Power Supply Rejection Ratio vs. Frequency

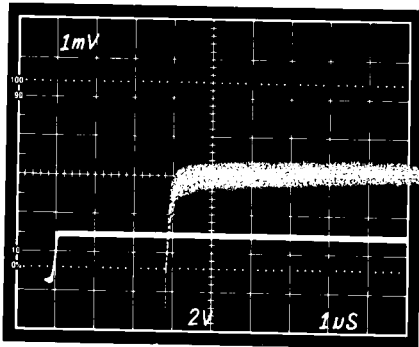

Positive-Going Settling Time
($V_{DD} = +15V$, $V_{SS} = -15V$)

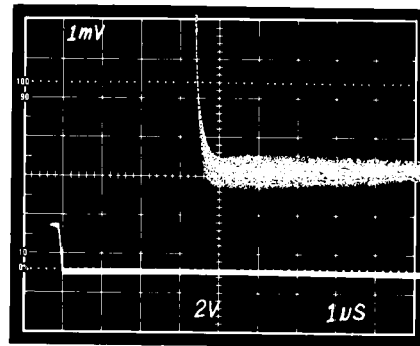

Negative-Going Settling Time
($V_{DD} = +15V$, $V_{SS} = -15V$)

CIRCUIT INFORMATION

D/A SECTION

The AD7245/AD7248 contains a 12-bit voltage-mode digital-to-analog converter. The output voltage from the converter has the same positive polarity as the reference voltage allowing single supply operation. The reference voltage for the DAC is provided by an on-chip buried-Zener diode.

The DAC consists of a highly stable, thin-film, R-2R ladder and twelve high-speed NMOS single-pole, double-throw switches. The simplified circuit diagram for this DAC is shown in Figure 1.

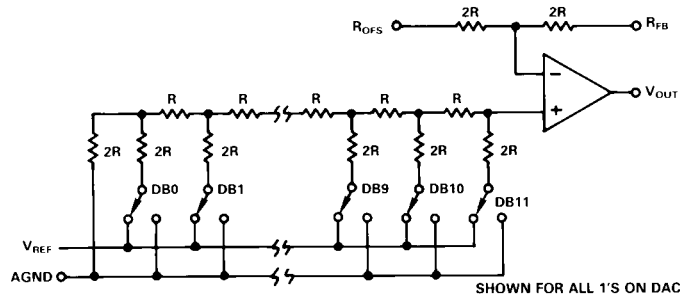

Figure 1. D/A Simplified Circuit Diagram

The input impedance of the DAC is code dependent and can vary from $8\text{k}\Omega$ to infinity. The input capacitance also varies with code, typically from 50pF to 200pF .

OP AMP SECTION

The output of the voltage-mode D/A converter is buffered by a noninverting CMOS amplifier. The user has access to two gain setting resistors which can be connected to allow different output voltage ranges (discussed later). The buffer amplifier is capable of developing up to 10V across a $2\text{k}\Omega$ load to GND.

The output amplifier can be operated from a single positive power supply by tying $V_{SS} = \text{AGND} = 0\text{V}$. The amplifier can also be operated from dual supplies to allow a bipolar output range of -5V to $+5\text{V}$. *The amplifier should not be configured for the 0 to $+10\text{V}$ output range when V_{SS} is more negative than -5V .* For dual supply operation on this range a V_{SS} of -5V should be applied to the part. The advantage of having dual supplies for the unipolar output ranges are faster settling time (τ) voltages near 0V , full-sink capability of 2.5mA maintained over the entire output range and elimination of the effects of negative offset on the transfer characteristic (outlined previously). Figure 2 shows the sink capability of the amplifier for single supply operation.

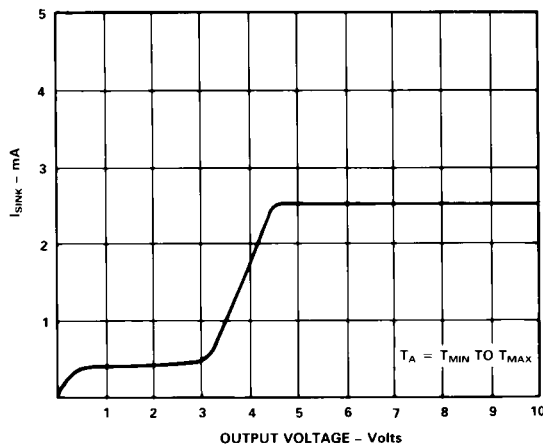

Figure 2. Typical Single Supply Sink Current vs. Output Voltage

The small-signal (200mV p-p) bandwidth of the output buffer amplifier is typically 1MHz . The output noise from the amplifier is low with a figure of $25\text{nV}/\sqrt{\text{Hz}}$ at a frequency of 1kHz . The broadband noise from the amplifier has a typical peak-to-peak figure of $150\mu\text{V}$ for a 1MHz output bandwidth. There is no significant difference in the output noise between single and dual supply operation.

VOLTAGE REFERENCE

The AD7245/AD7248 contains an internal low-noise buried-Zener diode reference which is trimmed for absolute accuracy and temperature coefficient. The reference is internally connected to the DAC. Since the DAC has a variable input impedance at its reference input the Zener diode reference is buffered. This buffered reference is available to the user to drive the circuitry required for bipolar output ranges. It can be used as a reference for other parts in the system provided it is externally buffered. The reference will give long-term stability comparable with the best discrete Zener reference diodes. The performance of the AD7245/AD7248 is specified with internal reference, and all the testing and trimming is done with this reference. The reference should be decoupled at the REF OUT pin and recommended decoupling components are $10\mu\text{F}$ and $0.1\mu\text{F}$ capacitors in series with a 10Ω resistor. A simplified schematic of the reference circuitry is shown in Figure 3.

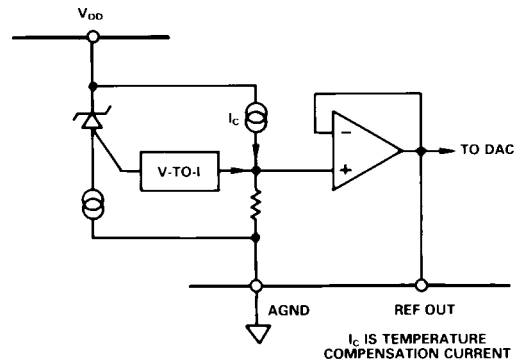

Figure 3. Internal Reference

DIGITAL SECTION

The AD7245/AD7248 digital inputs are compatible with either TTL or 5V CMOS levels. All data inputs are static-protected MOS gates with typical input currents of less than 1nA . The control inputs sink higher currents ($150\mu\text{A}$ max) as a result of the fast digital interfacing. Internal input protection of all logic inputs is achieved by on-chip distributed diodes.

The AD7245/AD7248 features a very low digital feedthrough figure of 10nV secs in a 5V output range. This is due to the voltage-mode configuration of the DAC. Most of the impulse is actually as a result of feedthrough across the package. Normally, ceramic packages show more feedthrough than the other packages because of the metal lid. However, on the AD7245, the lid of the ceramic package is connected to DGND (Pin 12), and this reduces the feedthrough. The AD7248 metal lid is not connected to DGND on the package, but this can be done externally to reduce the feedthrough.

INTERFACE LOGIC INFORMATION – AD7245

Table I shows the truth table for AD7245 operation. The part contains two 12-bit latches, an input latch and a DAC latch. \overline{CS} and \overline{WR} control the loading of the input latch while \overline{LDAC} controls the transfer of information from the input latch to the DAC latch. All control signals are level-triggered; and therefore either or both latches may be made transparent, the input latch by keeping \overline{CS} and \overline{WR} “LOW”, the DAC latch by keeping \overline{LDAC} “LOW”. Input data is latched on the rising edge of \overline{WR} .

The data held in the DAC latch determines the analog output of the converter. Data is latched into the DAC latch on the rising edge of \overline{LDAC} . This \overline{LDAC} signal is an asynchronous signal and is independent of \overline{WR} . This is useful in many applications. However, in systems where the asynchronous \overline{LDAC} can occur during a write cycle (or vice versa) care must be taken to ensure that incorrect data is not latched through to the output. For example, if \overline{LDAC} goes LOW while \overline{WR} is “LOW”, then the \overline{LDAC} signal must stay LOW for t_7 or longer after \overline{WR} goes high to ensure correct data is latched through to the output.

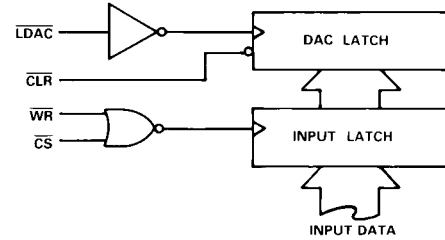

Figure 4. AD7245 Input Control Logic

CLR	LDAC	WR	CS	Function
H	L	L	L	Both Latches are Transparent
H	H	H	X	Both Latches are Latched
H	H	X	H	Both Latches are Latched
H	H	L	L	Input Latches Transparent
H	H	\uparrow	L	Input Latches Latched
H	L	H	H	DAC Latches Transparent
H	\uparrow	H	H	DAC Latches Latched
L	X	X	X	DAC Latches Loaded with all 0s
\uparrow	H	H	H	DAC Latches Latched with All 0s and Output Remains at 0V or -5V
\uparrow	L	L	L	Both Latches are Transparent and Output Follows Input Data

H = High State L = Low State X = Don't Care

Table I. AD7245 Truth Table

The contents of the DAC latch are reset to all 0s by a low level on the \overline{CLR} line. With both latches transparent, the \overline{CLR} line functions like a zero override with the output brought to 0V in the unipolar mode and -5V in the bipolar mode for the duration of the \overline{CLR} pulse. If both latches are latched, a “LOW” pulse on the \overline{CLR} input latches all 0s into the DAC latch and the output remains at 0V (or -5V) after the \overline{CLR} line has returned “HIGH”. The \overline{CLR} line can be used to ensure powerup to 0V on the AD7245 output in unipolar operation and is also useful, when used as a zero override, in system calibration cycles.

Figure 4 shows the input control logic for the AD7245 and the write cycle timing for the part is shown in Figure 5.

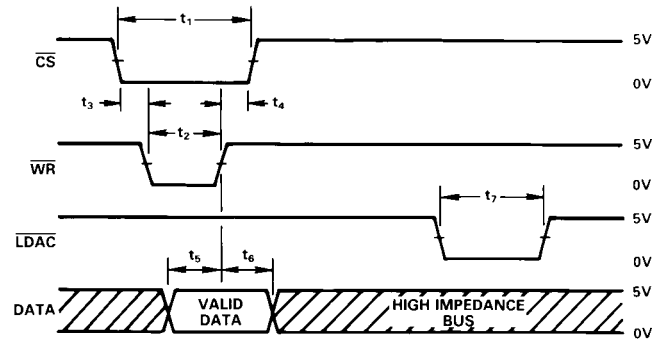

- NOTES
- SEE TIMING SPECIFICATIONS.
 - ALL INPUT RISE AND FALL TIMES MEASURED FROM 10% TO 90% OF +5V. $t_1, t_4 = 5nS$
 - TIMING MEASUREMENT REFERENCE LEVEL IS $\frac{V_{INH} + V_{INL}}{2}$
 - IF \overline{LDAC} IS ACTIVATED WHILE \overline{WR} IS LOW THEN \overline{LDAC} MUST STAY LOW FOR t_7 , OR LONGER AFTER \overline{WR} GOES HIGH.

Figure 5. AD7245 Write-Cycle Timing Diagram

INTERFACE LOGIC INFORMATION – AD7248

The input loading structure on the AD7248 is configured for interfacing to microprocessors with an 8-bit-wide data bus. The part contains two 12-bit latches – an input latch and a DAC latch. Only the data held in the DAC latch determines the analog output from the converter. The truth table for AD7248 operation is shown in Table II, while the input control logic is shown in Figure 6.

\overline{CSMSB} , \overline{CSLSB} and \overline{WR} control the loading of data from the external data bus to the input latch. The eight data inputs on the AD7248 accept right-justified data. This data is loaded to the input latch in two separate write operations. \overline{CSLSB} and \overline{WR} control the loading of the lower 8-bits into the 12-bit-wide latch. The loading of the upper 4-bit nibble is controlled by \overline{CSMSB} and \overline{WR} . All control inputs are level triggered, and input data for either the lower byte or upper 4-bit nibble is latched into the input latches on the rising edge of \overline{WR} (or either \overline{CSMSB} or \overline{CSLSB}). The order in which the data is loaded to the input latch (i.e., lower byte or upper 4-bit nibble first) is not important.

The \overline{LDAC} input controls the transfer of 12-bit data from the input latch to the DAC latch. This \overline{LDAC} signal is also level triggered, and data is latched into the DAC latch on the rising edge of \overline{LDAC} . The \overline{LDAC} input is asynchronous and independent of \overline{WR} . This is useful in many applications especially in the simultaneous updating of multiple AD7248 outputs. However, in systems where the asynchronous \overline{LDAC} can occur during a write cycle (or vice versa) care must be taken to ensure that

incorrect data is not latched through to the output. In other words, if $\overline{\text{LDAC}}$ goes low while $\overline{\text{WR}}$ and either $\overline{\text{CS}}$ input are low (or $\overline{\text{WR}}$ and either $\overline{\text{CS}}$ go low while $\overline{\text{LDAC}}$ is low), then the $\overline{\text{LDAC}}$ signal must stay low for t_7 or longer after $\overline{\text{WR}}$ returns high to ensure correct data is latched through to the output. The write cycle timing diagram for the AD7248 is shown in Figure 7.

An alternate scheme for writing data to the AD7248 is to tie the $\overline{\text{CSMSB}}$ and $\overline{\text{LDAC}}$ inputs together. In this case exercising $\overline{\text{CSLSB}}$ and $\overline{\text{WR}}$ latches the lower 8 bits into the input latch. The second write, which exercises $\overline{\text{CSMSB}}$, $\overline{\text{WR}}$ and $\overline{\text{LDAC}}$ loads the upper 4-bit nibble to the input latch and at the same time transfers the 12-bit data to the DAC latch. This automatic transfer mode updates the output of the AD7248 in two write operations. This scheme works equally well for $\overline{\text{CSLSB}}$ and $\overline{\text{LDAC}}$ tied together provided the upper 4-bit nibble is loaded to the input latch followed by a write to the lower 8 bits of the input latch.

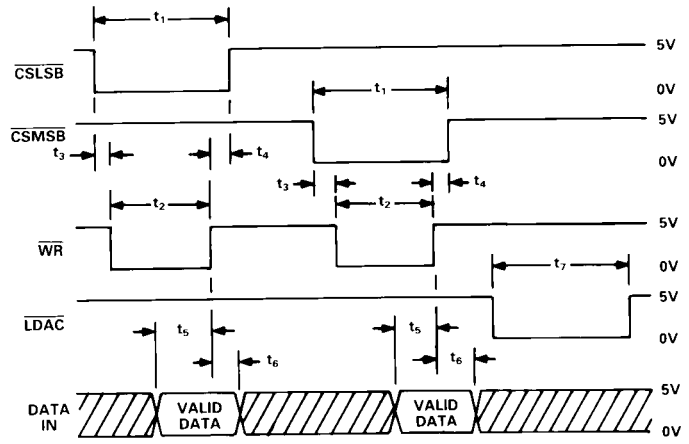

Figure 7. AD7248 Write Cycle Timing Diagram

CSLSB	CSMSB	WR	LDAC	Function
L	H	L	H	Loads LS Byte into Input Latch
L	H	$\overline{\text{L}}$	H	Latches LS Byte into Input Latch
$\overline{\text{L}}$	H	L	H	Latches LS Byte into Input Latch
H	L	L	H	Loads MS Nibble into Input Latch
H	L	$\overline{\text{L}}$	H	Latches MS Nibble into Input Latch
H	$\overline{\text{L}}$	L	H	Latches MS Nibble into Input Latch
H	H	H	L	Loads Input Latch into DAC Latch
H	H	H	$\overline{\text{L}}$	Latches Input Latch into DAC Latch
H	L	L	L	Loads MS Nibble into Input Latch and Loads Input Latch into DAC Latch
H	H	H	H	No Data Transfer Operation

H = High State L = Low State

Table II. AD7248 Truth Table

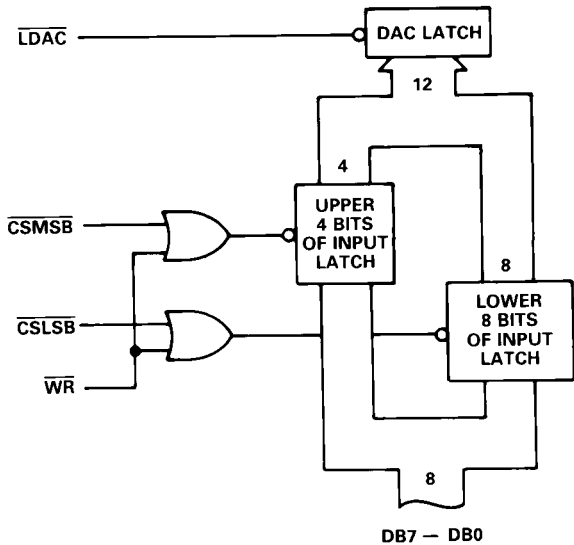

Figure 6. AD7248 Input Control Logic

APPLYING THE AD7245/AD7248

The internal scaling resistors provided on the AD7245/AD7248 allow several output voltage ranges. The part can produce unipolar output ranges of 0V to +5V or 0V to +10V and a bipolar output range of -5V to +5V. Connections for the various ranges are outlined below.

UNIPOLAR (0V to +10V) CONFIGURATION

The first of the configurations provides an output voltage range of 0V to +10V. This is achieved by connecting the bipolar offset resistor, R_{OFS} , to AGND and connecting R_{FB} to V_{OUT} . In this configuration the AD7245/AD7248 can be operated single supply ($V_{\text{SS}} = 0\text{V} = \text{AGND}$). If dual supply performance is required, a V_{SS} of -5V should be applied. Note that a V_{SS} supply more negative than -5V should not be applied to the AD7245/AD7248 when it is configured for a 0 to +10V output range. Figure 8 shows the connection diagram for unipolar operation while the table for output voltage versus the digital code in the DAC latch is shown in Table III.

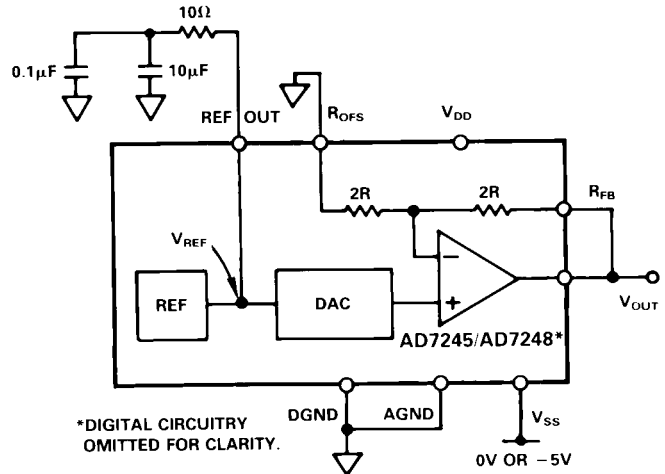

Figure 8. Unipolar (0 to +10V) Configuration

programmable current sink from V_{DD} or V_{SOURCE} . The VN0300M is placed in the feedback of the AD7245/AD7248 amplifier. The entire circuit can be operated in single supply by tying the V_{SS} of the AD7245/AD7248 to AGND. The sink current, I_{SINK} , can be expressed as:

$$I_{SINK} = \frac{D \cdot V_{REF}}{R1}$$

Using the VN0300M, the voltage drop across the load can typically be as large as $(V_{SOURCE} - 6V)$ with V_{OUT} of the DAC at $+5V$. Therefore, for a current of 50mA flowing in the R1 (with all 1s in the DAC register) the maximum load is 200Ω with $V_{SOURCE} = +15V$. The VN0300M can actually handle currents up to 500mA and still function correctly in the circuit, but in practice the circuit must be used with larger values of V_{SOURCE} otherwise it requires a very small load.

Since the tolerance value on the reference voltage of the AD7245/AD7248 is $\pm 0.2\%$, then the absolute value of I_{SINK} can vary by $\pm 0.2\%$ from device to device for a fixed value of R1.

Because the input bias current of the AD7245/AD7248's op amp is only of the order of pA's, its effect on the sink current is negligible. Tying the R_{OFS} input to the R_{FB} input reduces this effect even further and prevents noise pickup which could occur if the R_{OFS} pin was left unconnected.

The circuit of Figure 10 can be modified to provide a programmable current source to AGND or $-V_{SINK}$ (for $-V_{SINK}$, dual supplies are required on the AD7245/AD7248). The AD7245/AD7248 is configured as before. The current through R1 is mirrored with a current mirror circuit to provide the programmable source current (see CMOS DAC Application Guide, Publication No. G872-30-10/84, for suitable current mirror circuit). As before the absolute value of the source current will be affected by the

$\pm 0.2\%$ tolerance on V_{REF} . In this case the performance of the current mirror will also affect the value of the source current.

FUNCTION GENERATOR WITH PROGRAMMABLE FREQUENCY

Figure 11 shows how the AD7245/AD7248 can be configured with the AD537, voltage-to-frequency converter and the AD639, trigonometric function generator to provide a complete function generator with programmable frequency. The circuit provides square-wave, triwave and sine wave outputs, each output of $\pm 10V$ amplitude.

The AD7245/AD7248 provides a programmable voltage to the AD537 input. Since both the AD7245/AD7248 and AD537 are guaranteed monotonic, the output frequency will always increase with increasing digital code. The AD537 provides a square-wave output which is conditioned for $\pm 10V$ by amplifier A1. The AD537 also provides a differential triwave output. This is conditioned by amplifiers A2 and A3 to provide the $\pm 1.8V$ triwave required at the input of the AD639. The triwave is further scaled by amplifier A4 to provide a $\pm 10V$ output.

Adjusting the triwave applied to the AD639 adjusts the distortion performance of the sine wave output, ($+10V$ in configuration shown). Amplitude, offset and symmetry of the triwave can affect the distortion. By adjusting these, via VR1 and VR2, an output sine wave with harmonic distortion of better than $-50dB$ can be achieved at low and intermediate frequencies.

Using the capacitor value shown in Figure 11 for C_F (i.e. 680pF) the output frequency range is 0 to 100kHz over the digital input code range. The step size for frequency increments is 25Hz. The accuracy of the output frequency is limited to 8 or 9 bits by the AD537, but it is guaranteed monotonic to 12 bits.

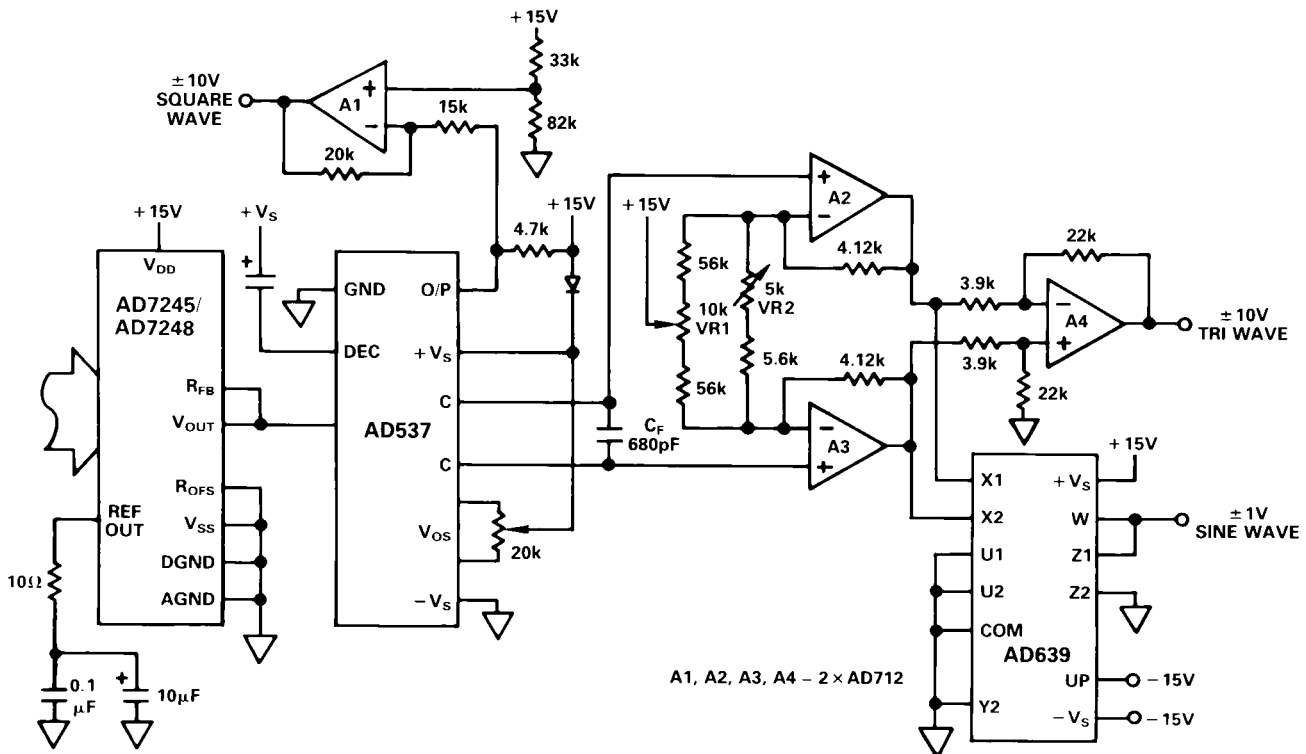

Figure 11. Programmable Function Generator

MICROPROCESSOR INTERFACING – AD7245

AD7245 – 8086A INTERFACE

Figure 12 shows the 8086 16-bit processor interfacing to the AD7245. In the setup shown the double-buffering feature of the DAC is not used and the $\overline{\text{LDAC}}$ input is tied LOW. AD0-AD11 of the 16-bit data bus are connected to the AD7245 data bus (DB0-DB11). The 12-bit word is written to the AD7245 in one MOV instruction and the analog output responds immediately. In this example the DAC address is D000. A software routine for Figure 12 is given in Table V.

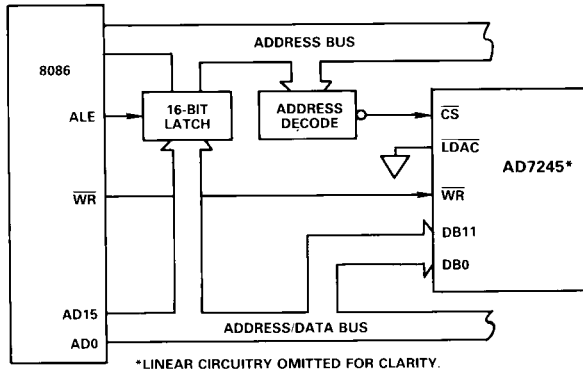

Figure 12. AD7245 to 8086 Interface

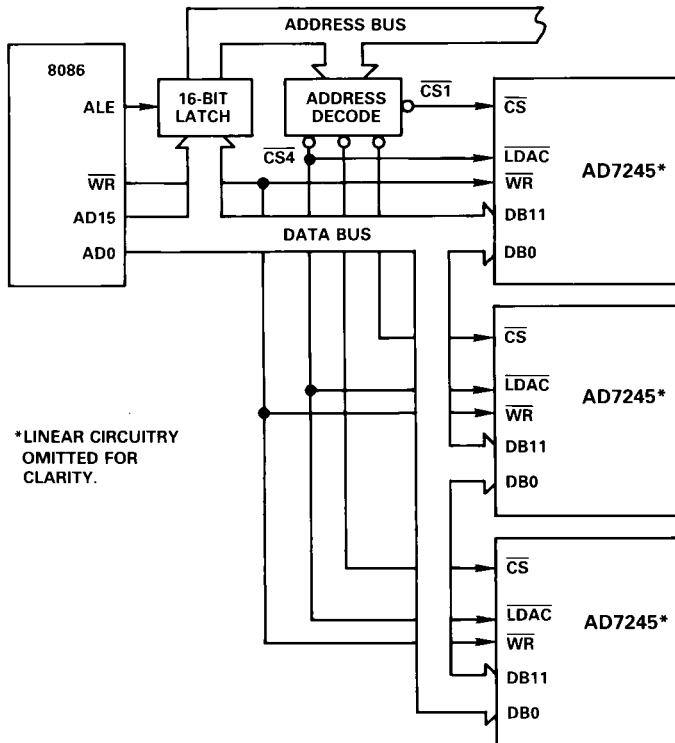

Figure 13. AD7245 to 8086 Multiple DAC Interface

ASSUME DS : DACLOAD, CS : DACLOAD
DACLOAD SEGMENT AT 000

00	8CC9	MOV CX,	: DEFINE DATA SEGMENT
		CS	REGISTER
02	8ED9	MOV DS,	: EQUAL TO CODE
		CX	SEGMENT REGISTER
04	BF00D0	MOV DI,	: LOAD DI WITH D000
		#D000	
07	C705	MOV MEM,	: DAC LOADED WITH WXYZ
		"YZWX"	#YZWX
0B	EA00 00		: CONTROL IS RETURNED TO
0E	00 FF		THE MONITOR PROGRAM

Table V. Sample Program for Loading AD7245 from 8086

In a multiple DAC system the double-buffering of the AD7245 allows the user to simultaneously update all DACs. In Figure 13, a 12-bit word is loaded to the input latches of each of the DACs in sequence. Then, with one instruction to the appropriate address, $\overline{\text{CS4}}$ (i.e., $\overline{\text{LDAC}}$) is brought LOW, updating all the DACs simultaneously.

AD7245 – MC68000 INTERFACE

Interfacing between the MC68000 and the AD7245 is accomplished using the circuit of Figure 14. Once again the AD7245 is used in the single-buffered mode. A software routine for loading data to the AD7245 is given in Table VI. In this example the AD7245 is located at address E000, and the 12-bit word is written to the DAC in one MOVE instruction.

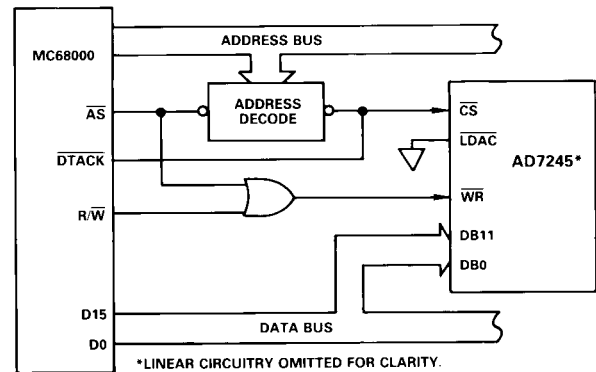

Figure 14. AD7245 to 68000 Interface

01000	MOVE.W	#X,D0	The desired DAC data, X, is loaded into Data Register 0. X may be any value between 0 and 4095 (decimal) or 0 and OFFF (hexadecimal).
	MOVE.W	D0,\$E000	The Data X is transferred between D0 and the DAC Latch.
	MOVE.B	#228,D7	Control is returned to the System Monitor Program using these two instructions.
	TRAP	#14	

Table VI. Sample Routine for Loading AD7245 from 68000

MICROPROCESSOR INTERFACING – AD7248

Figure 15 shows the connection diagram for interfacing the AD7248 to both the 8085A and 8088 microprocessors. This scheme is also suited to the Z80 microprocessor, but the Z80 address/data bus does not have to be demultiplexed. Data to be loaded to the AD7248 is right-justified. The AD7248 is memory mapped with a separate memory address for the input latch high byte, the input latch low byte and the DAC latch. Data is first written to the AD7248 input latch in two write operations. Either the high byte or the low byte data can be written first to the AD7248 input latch. A write to the AD7248 DAC latch address transfers the input latch data to the DAC latch and updates the output voltage. Alternatively, the LDAC input can be asynchronous or can be common to a number of AD7248s for simultaneous updating of a number of voltage channels.

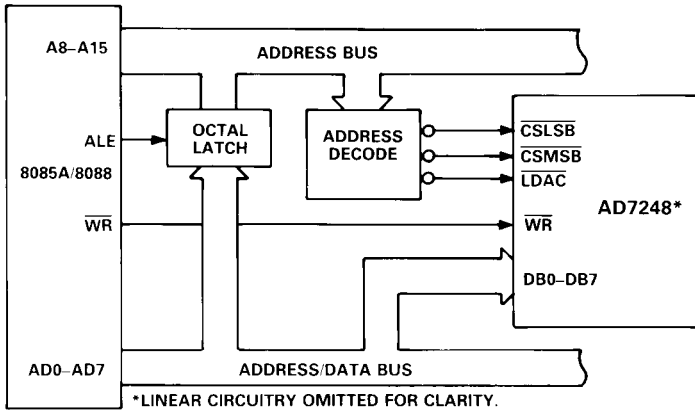

Figure 15. AD7248 to 8085A/8088 Interface

A connection diagram for the interface between the AD7248 and 68008 microprocessor is shown in Figure 16. Once again, the AD7248 acts as a memory mapped device and data is right-justified. In this case the AD7248 is configured in the automatic transfer mode which means that the high byte of the input latch has the same address as the DAC latch. Data is written to the AD7248 by first writing data to the AD7248 low byte. Writing data to the high byte of the input latch also transfers the input latch contents to the DAC latch and updates the output.

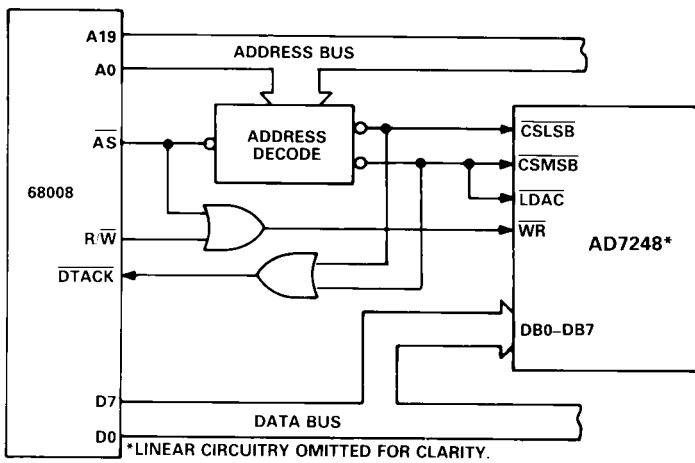

Figure 16. AD7248 to 68008 Interface

An interface circuit for connections to the 6502 or 6809 microprocessors is shown in Figure 17. Once again, the AD7248 is memory mapped and data is right-justified. The procedure for writing data to the AD7248 is as outlined for the 8085A/8088. For the 6502 microprocessor the $\phi 2$ clock is used to generate the \overline{WR} , while for the 6809 the E signal is used.

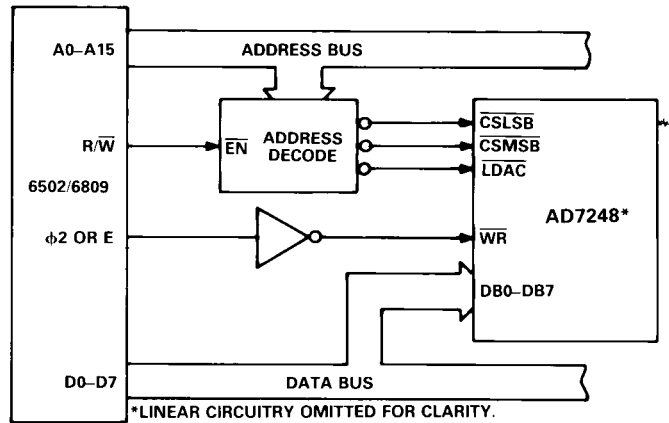

Figure 17. AD7248 to 6502/6809 Interface

Figure 18 shows a connection diagram between the AD7248 and the 8051 microprocessor. The AD7248 is port mapped in this interface and is configured in the automatic transfer mode. Data to be loaded to the input latch low byte is output to Port 1. Output Line P3.0, which is connected to \overline{CSLSB} of the AD7248, is pulsed to load data into the low byte of the input latch. Pulsing the P3.1 line, after the high byte data has been set up on Port 1, updates the output of the AD7248. The \overline{WR} input of the AD7248 can be hardwired low in this application because spurious address strobes on \overline{CSLSB} and \overline{CSMSB} do not occur.

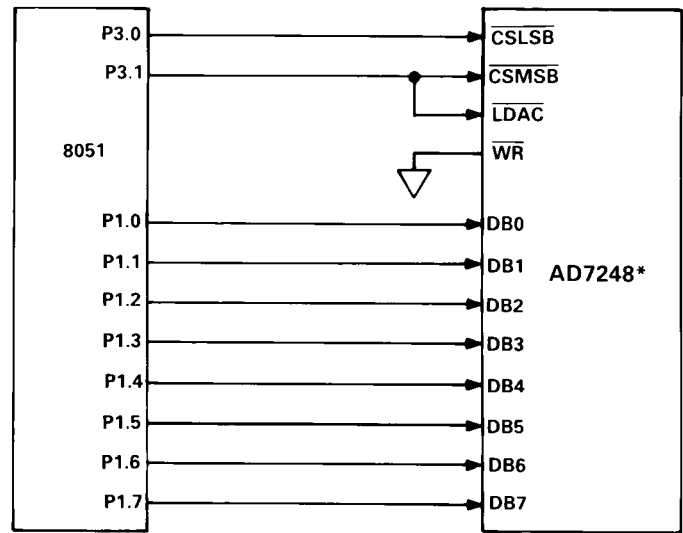

Figure 18. AD7248 to MCS-51 Interface

AD7245 ORDERING INFORMATION

Relative Accuracy (LSB)	Temperature Range and Package		
	0 to +70°C	-25°C to +85°C	-55°C to +125°C
±1	Plastic DIP	Hermetic DIP ¹	Hermetic DIP ^{1,2}
	AD7245JN	AD7245AQ	AD7245SQ
±1	PLCC ³		LCCC ⁴
	AD7245JP		AD7245SE

NOTES

¹Analog Devices reserves the right to ship either ceramic (D-24A) or cerdip (Q-24) hermetic packages.

²To order MIL-STD-883, Class B processed parts, add /883B to part number. Contact your local sales office for military data sheet.

³PLCC: Plastic Leaded Chip Carrier.

⁴LCCC: Leadless Ceramic Chip Carrier.

AD7245 PRICING (100s)

AD7245JN	\$ 9.85	AD7245SQ	\$38.55
AD7245JP	\$11.35	AD7245SE	\$67.50
AD7245AQ	\$12.85		

AD7248 ORDERING INFORMATION

Relative Accuracy (LSB)	Temperature Range and Package		
	0 to +70°C	-25°C to +85°C	-55°C to +125°C
±1	Plastic DIP	Hermetic DIP ¹	Hermetic DIP ^{1,2}
	AD7248JN	AD7248AQ	AD7248SQ
±1	PLCC ³		LCCC ⁴
	AD7248JP		AD7248SE

NOTES

¹Analog Devices reserves the right to ship either ceramic (D-20) or cerdip (Q-20) hermetic packages.

²To order MIL-STD-883, Class B processed parts, add /883B to part number. Contact your local sales office for military data sheet.

³PLCC: Plastic Leaded Chip Carrier.

⁴LCCC: Leadless Ceramic Chip Carrier.

AD7248 PRICING (100s)

AD7248JN	\$ 9.85	AD7248SQ	\$38.55
AD7248JP	\$11.35	AD7248SE	\$67.50
AD7248AQ	\$12.85		

MECHANICAL INFORMATION – AD7245

OUTLINE DIMENSION

Dimensions shown in inches and (mm).

24-Pin Plastic DIP (N-24)

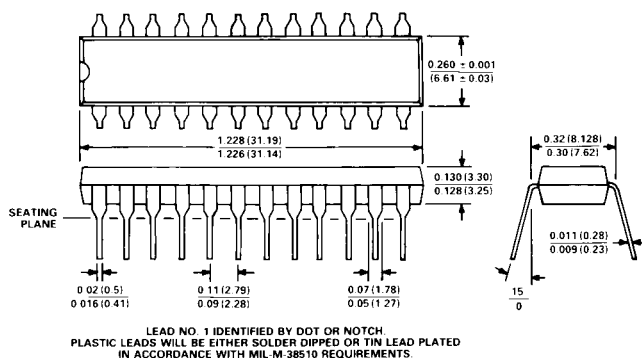

24-Pin Ceramic DIP (D-24A)

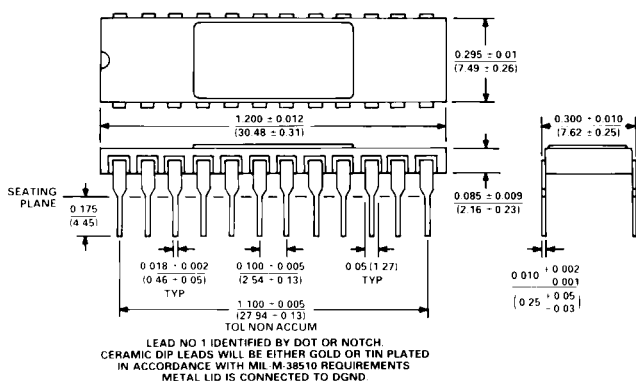

24-Pin Cerdip (Q-24)

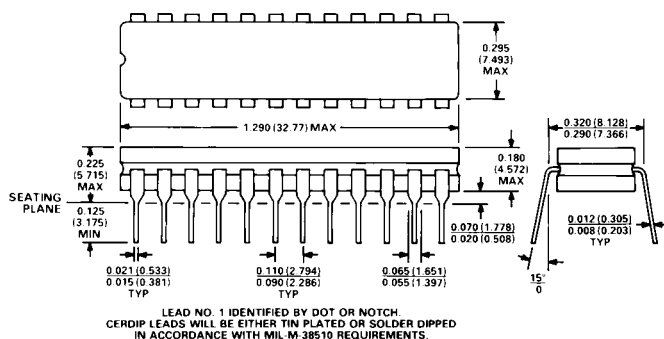

28-Terminal Leadless Ceramic Chip Carrier (E-28A)

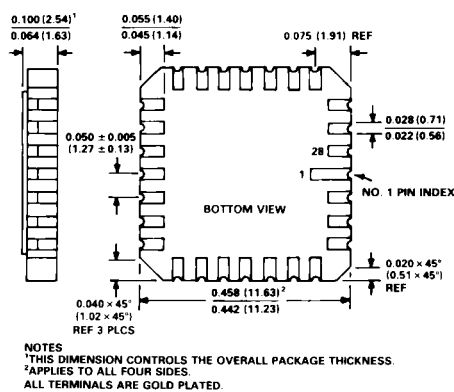

28-Terminal Plastic Leaded Chip Carrier (P-28A)

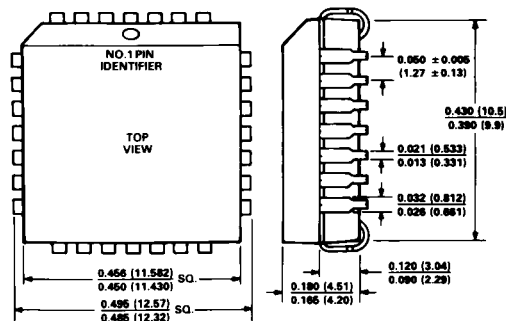

MECHANICAL INFORMATION - AD7248

OUTLINE DIMENSIONS

Dimensions shown in inches and (mm).

20-Pin Ceramic DIP (D-20)

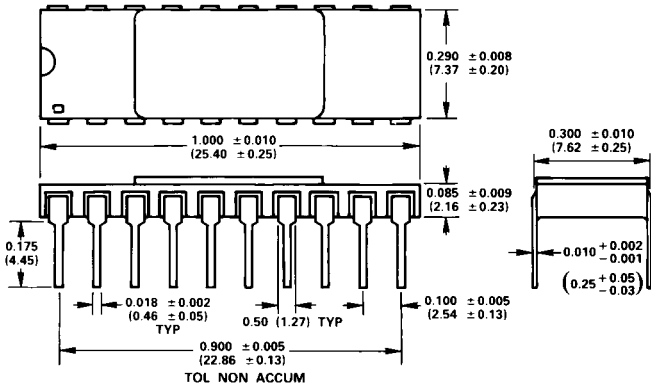

TOL NON ACCUM
 LEAD NUMBER 1 IDENTIFIED BY DOT OR NOTCH.
 LEADS WILL BE EITHER GOLD OR TIN PLATED IN ACCORDANCE WITH MIL-M-38510 REQUIREMENTS.

20-Pin Cerdip (Q-20)

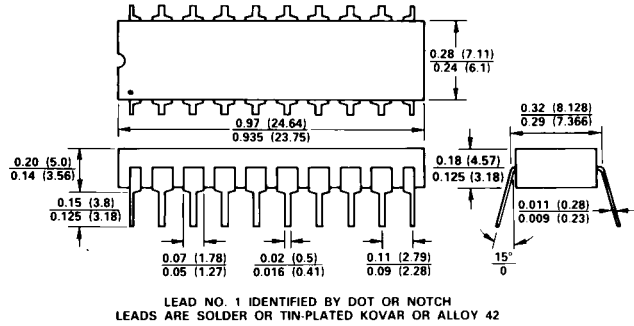

LEAD NO. 1 IDENTIFIED BY DOT OR NOTCH
 LEADS ARE SOLDER OR TIN-PLATED KOVAR OR ALLOY 42

20-Pin Plastic DIP (N-20)

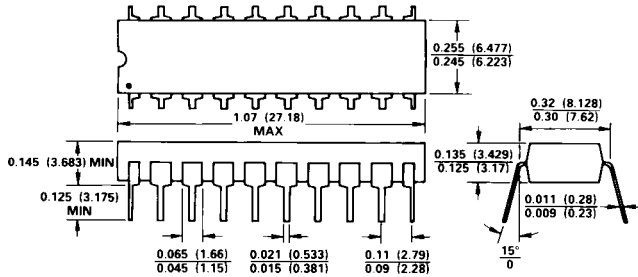

LEAD NO. 1 IDENTIFIED BY DOT OR NOTCH
 LEADS ARE SOLDER OR TIN-PLATED KOVAR OR ALLOY 42

20-Terminal Leadless Ceramic Chip Carrier (E-20A)

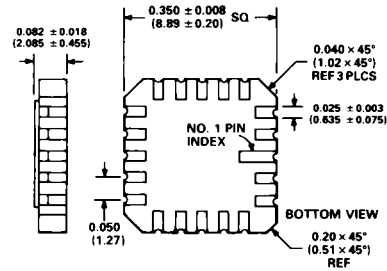

20-Terminal Plastic Leaded Chip Carrier (P-20A)

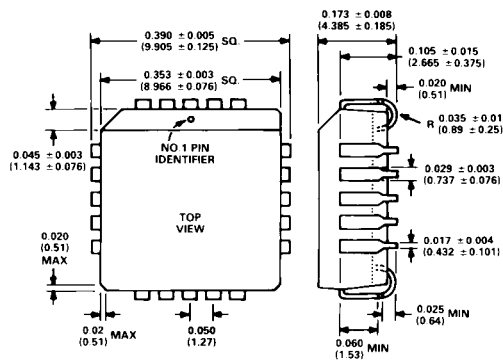

C1139a-5-589

PRINTED IN U.S.A.



LittleDiode supplies new, hard to find or obsolete electronic components and semiconductors all over the world.

With over two million different components listed you are sure to find the part you need.

Feel free to visit us today at our online store:

LittleDiode.com

Looking forward to providing you with the best possible service.