

Dolby* B Type Noise Reduction System

Description

CXA1100, CXA1101, CXA1102 and CXA1163 are ICs including two separate Dolby B type noise reduction processors. Seven devices with four Dolby levels and two types of package are provided for various applications. These devices feature very few external components, which is achieved by integrated filter circuits using integrated thin film capacitors with high capacitance.

16 pin DIP (Plastic)

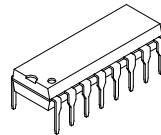

16 pin SOP (Plastic)

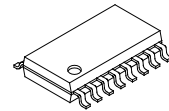

Features

- Minimum number of external components
- NR ON/OFF and REC/PB switches included
- Small package (DIP16, SOP16)
- Small supply current ($\approx 5.5\text{mA}$, Typ.)
- Dual channel processors in one chip

Absolute Maximum Ratings (Ta = 25°C)

- Supply voltage V_{CC} 17 V
- Operating temperature T_{opr} -30 to +85 °C
- Storage temperature T_{stg} -55 to +150 °C
- Allowable power dissipation P_D
 - DIP16 (A1100P/A1101P/A1102P/A1163P) 900 mW
 - SOP16 (A1101M/A1102M/A1163M) 500 mW

Note 1) These ICs are available only to the licensees of Dolby Laboratories Licensing Corporation from whom licensing and application information may be obtained.

Note 2) "Dolby" and double D symbols are trademarks of Dolby Laboratories Licensing Corporation.

Pin Description

(Ta = 25°C, Vcc = 12V (Single supply), No signal)

| No. | Symbol | Z (in) | VDC | Equivalent Circuit | Description |
|-------|----------|--------|-------|--------------------|--|
| 1, 16 | REC IN | 40kΩ | 6.0V | | Recording (Encode) input |
| 2 | Vcc | — | 12.0V | | Power supply |
| 3, 14 | PB IN | 40kΩ | 6.0V | | Playback (Decode) input |
| 4 | Vcc/2 | 1kΩ | 6.0V | | Single supply → Vcc/2 Split supply → Ground |
| 5 | ON/OFF | — | — | | Mode control pin for NR ON/OFF "H" → NR OFF "L" → NR ON |
| 6, 11 | LINE OUT | — | 6.0V | | Line (Decode) output |

| No. | Symbol | Z (in) | VDC | Equivalent Circuit | Description |
|-------|---------|--------|------|--------------------|---|
| 7, 10 | TC | — | 0.3V | | Time constant pin for the level detector |
| 8, 9 | REC OUT | — | 6.0V | | Recording (Encode) output |
| 12 | REC/PB | — | — | | Mode control pin for REC/PB (Encode/Decode) "H" → B (Decode) "L" → EC (Encode) |
| 13 | IREF | — | 1.2V | | Reference current input pin for the active filters |
| 15 | GND | — | 0V | | Single supply → Ground Split supply → V _{EE} |

Block Diagram

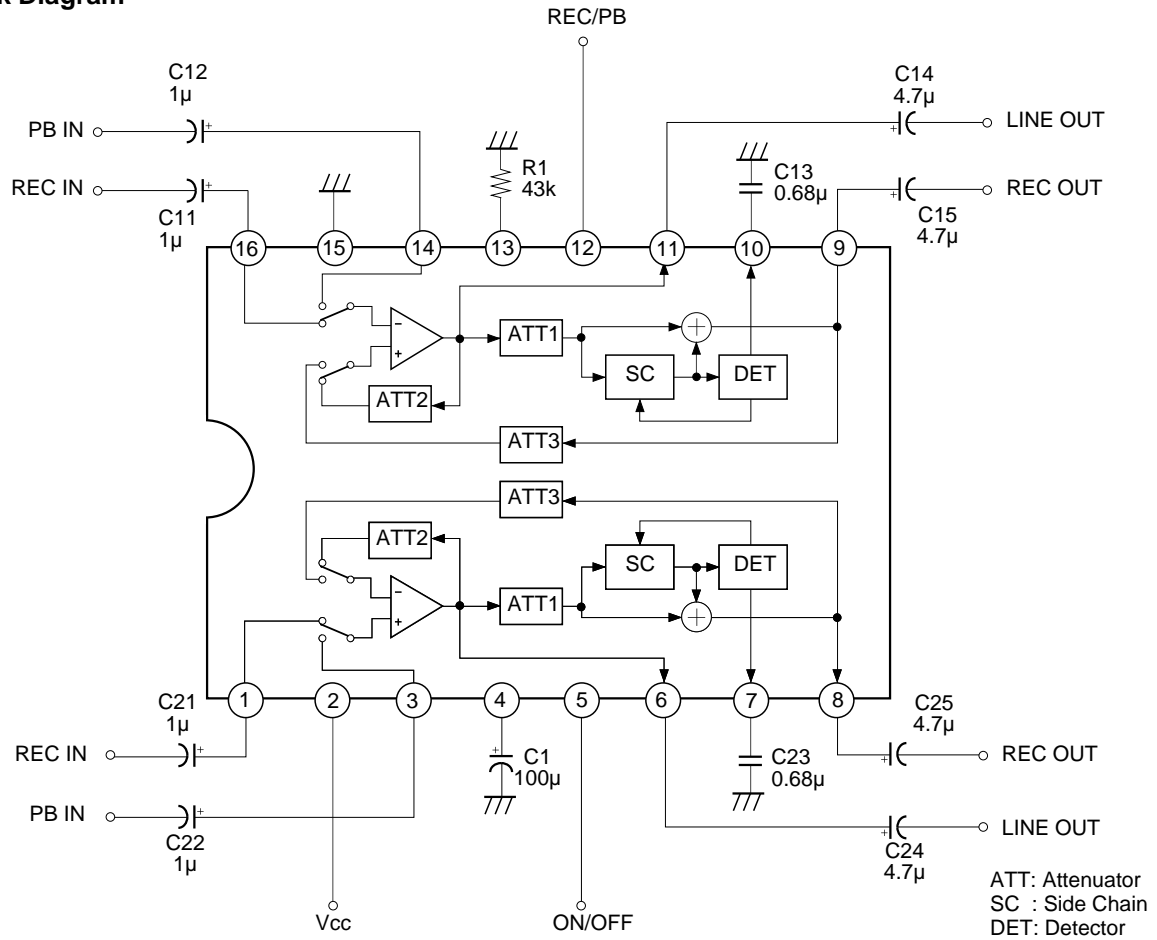

Test Circuit

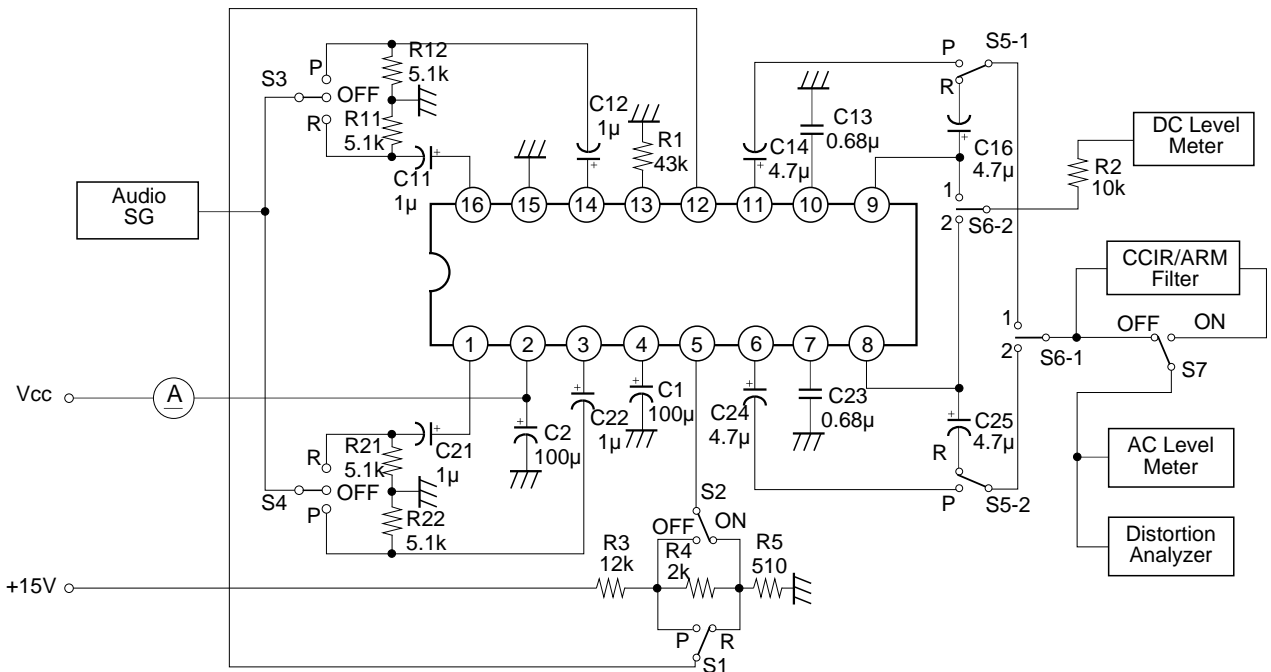

Electrical Characteristics

Ta = 25°C, Dolby Level: -10dBm (= 245mVrms) at REC OUT

Vcc = 15V (CXA1100), Vcc = 12V (CXA1101), Vcc = 9V (CXA1102)

Vcc = 6V (CXA1163)

| Item | Symbol | Test Condition* | | | | Min. | Typ. | Max. | Unit |
|---|--------|-----------------|-----|--------|---------------------------|-------------------------------|------------------------------|------------------------------|--------------------------|
| | | R/P | NR | f (Hz) | Other Conditions | | | | |
| Operating voltage CXA1100 CXA1101 CXA1102 CXA1163 | Vopr | — | — | — | Signal Handling ≥ 12dB | 11.5 8.5 6.5 5.0 | — — — — | 16.0 16.0 16.0 16.0 | V V V V |
| Supply current CXA1100 CXA1101 CXA1102 CXA1163 | Icc | R | OFF | — | No signal | 3.5 3.5 3.5 3.5 | 5.6 5.5 5.3 5.1 | 7.5 7.5 7.5 7.5 | mA mA mA mA |
| LINE OUT level CXA1100 CXA1101 CXA1102 CXA1163 | Vlout | R | OFF | 1k | | -1.0 -4.0 -7.0 -11.0 | 0.0 -3.0 -6.0 -10.0 | 1.0 -2.0 -5.0 -9.0 | dBm dBm dBm dBm |
| REC IN level | Vrin | R | OFF | 1k | | -32 | -30 | -28 | dBm |
| PB IN level | Vpin | P | OFF | 1k | | -32 | -30 | -28 | dBm |
| Encode characteristics (Boost) | | | | | | | | | |
| (1) | B-R-1 | R | ON | 500 | -25dB | 1.4 | 2.9 | 4.4 | dB |
| (2) | B-R-2 | R | ON | 2k | -25dB | 5.5 | 7.0 | 8.5 | dB |
| (3) | B-R-3 | R | ON | 5k | -25dB | 3.9 | 5.4 | 6.9 | dB |
| (4) | B-R-4 | R | ON | 10k | -40dB | 9.7 | 10.4 | 11.9 | dB |
| (5) | B-R-5 | R | ON | 10k | 0dB | -1.1 | 0.4 | 1.9 | dB |
| Signal handling CXA1100 CXA1101 CXA1102 CXA1163 | Vomax | R | OFF | 1k | THD = 1% | 13.5 14.0 14.0 13.0 | 15.3 15.9 15.9 15.0 | — — — — | dB dB dB dB |

0dBm = 0.775Vrms

| Item | Symbol | Test Condition* | | | | Min. | Typ. | Max. | Unit |
|---------------------------------|--------------|-----------------|-----|--------|------------------------|------|------|------|------|
| | | R/P | NR | f (Hz) | Other Conditions | | | | |
| Total harmonic distortion | | | | | | | | | |
| 1) NR OFF | THD (OFF) | R | OFF | 1k | +10dB | — | 0.03 | 0.2 | % |
| CXA1100 | | | | | | — | 0.04 | 0.2 | % |
| CXA1102 | | | | | | — | 0.05 | 0.2 | % |
| CXA1163 | | | | | | — | 0.06 | 0.2 | % |
| 2) NR ON | THD (ON) | R | ON | 1k | +10dB | — | 0.03 | 0.3 | % |
| CXA1100 | | | | | | — | 0.04 | 0.3 | % |
| CXA1102 | | | | | | — | 0.06 | 0.3 | % |
| CXA1163 | | | | | | — | 0.09 | 0.3 | % |
| Input impedance | | | | | | | | | |
| REC IN | Zrec | — | — | 1k | | 28 | 40 | 57 | kΩ |
| PB IN | Zpb | — | — | 1k | | 28 | 40 | 57 | kΩ |
| Encode S/N ratio | SN (CCIR) | R | ON | — | Rg = 5kΩ (CCIR/ARM) | 65 | 69 | — | dB |
| Crosstalk | | | | | | | | | |
| REC-PB | CT-1 | P | OFF | 1k | 0dB | — | -82 | -65 | dB |
| PB-REC | CT-2 | R | OFF | 1k | 0dB | — | -81 | -60 | dB |
| REC ch to ch | CT-3 | R | OFF | 1k | 0dB | — | -70 | -60 | dB |
| PB ch to ch | CT-4 | P | OFF | 1k | 0dB | — | -70 | -60 | dB |
| REC OUT | | | | | | | | | |
| Offset voltage (NR ON — OFF) | Voff | R | ON | — | | -40 | 0 | 40 | mV |
| Control voltage | | | | | | | | | |
| "H" Level | VC-H | — | — | — | | 2.5 | — | Vcc | V |
| "L" Level | VC-L | — | — | — | | 0 | — | 0.5 | V |

* 0dB means the level which provides the Dolby level at the recording output in the noise reduction off mode.

Example of Representative Characteristics

Quiescent Current vs. Supply Voltage

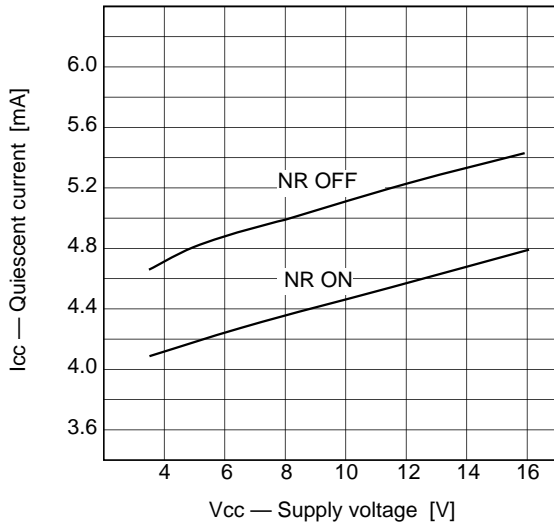

Supply Current vs. Input Voltage (CXA1101)

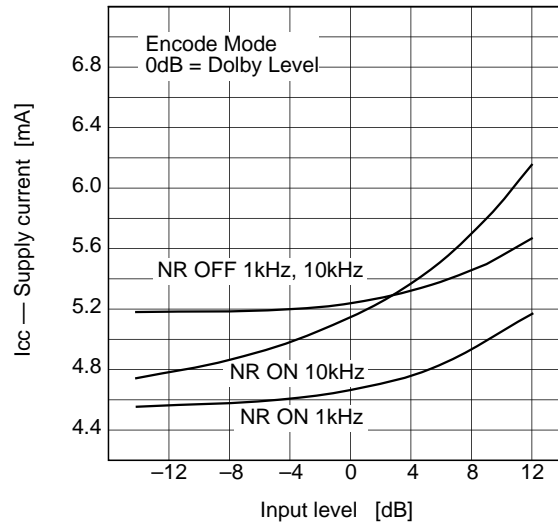

Encode Characteristics

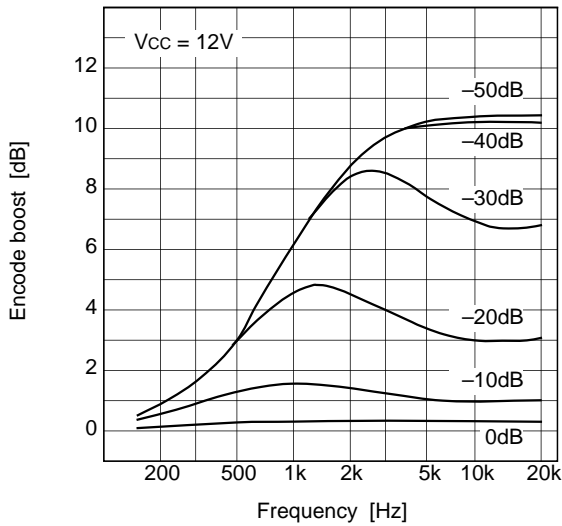

Temperature Characteristics

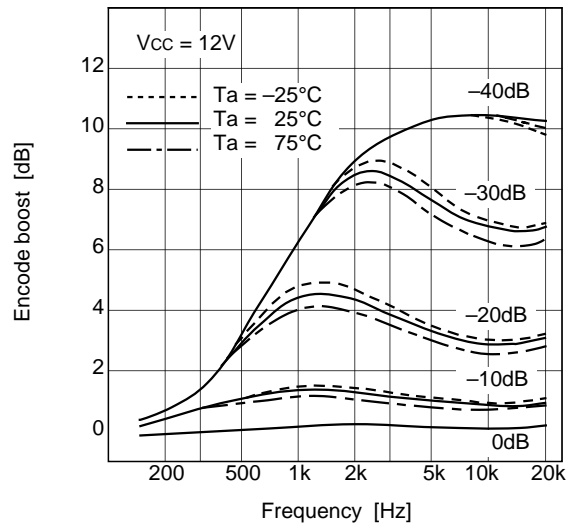

Signal Handling

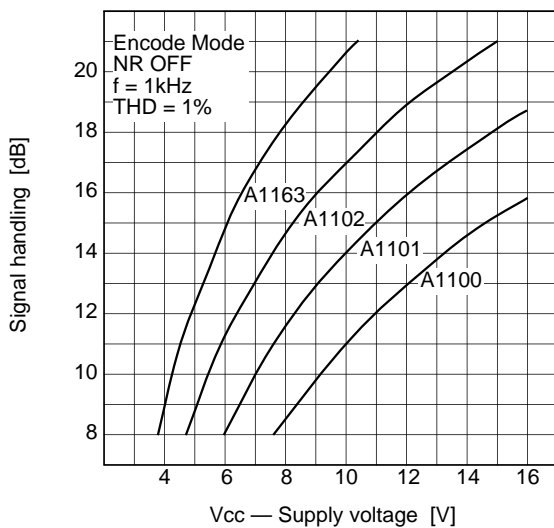

Load Characteristics (CXA1101)

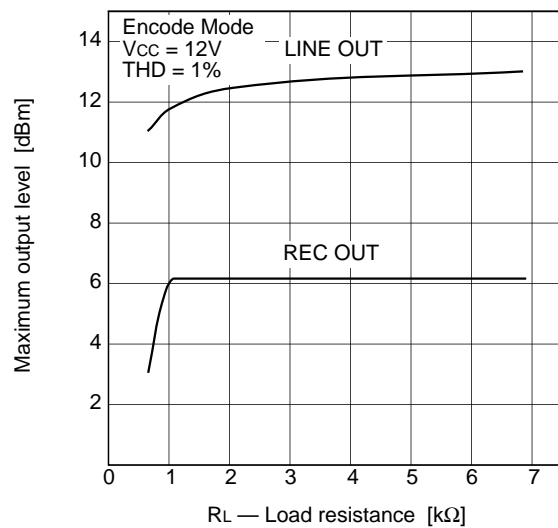

NR off Total Harmonic Distortion-1 (CXA1101)

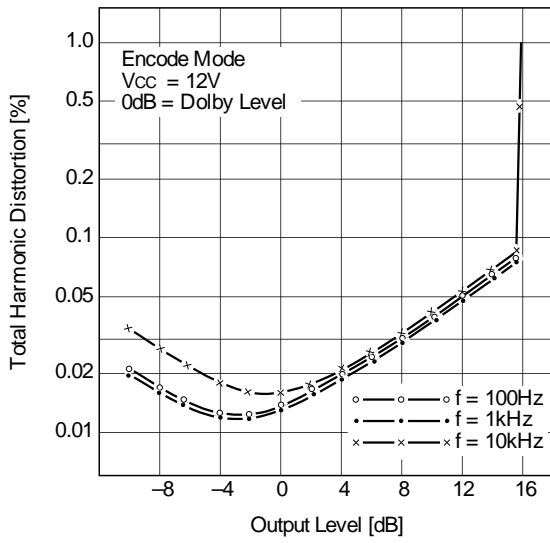

NR on Total Harmonic Distortion-1 (CXA1101)

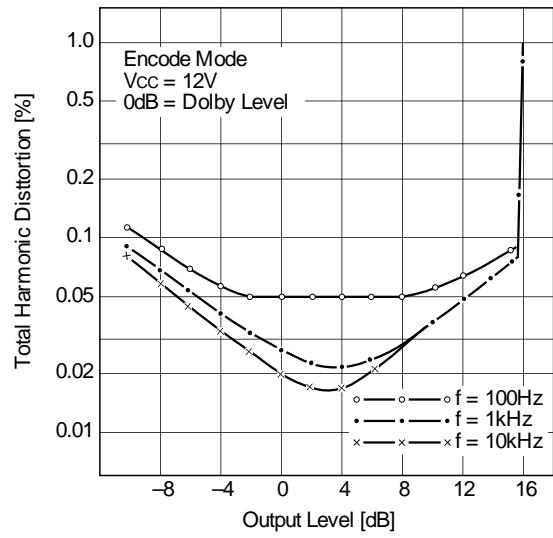

NR off Total Harmonic Distortion-2 (CXA1100)

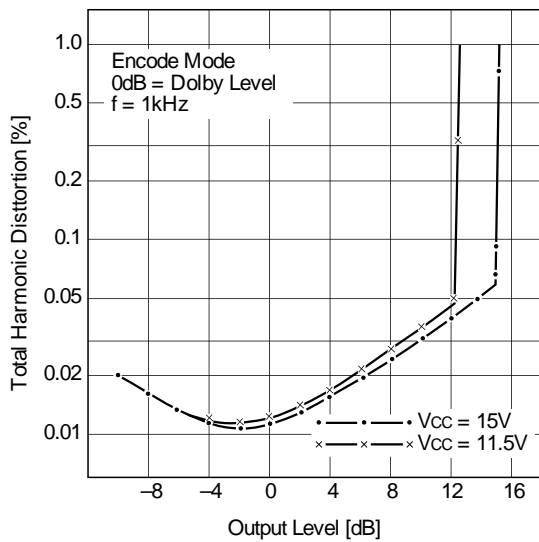

NR on Total Harmonic Distortion-2 (CXA1100)

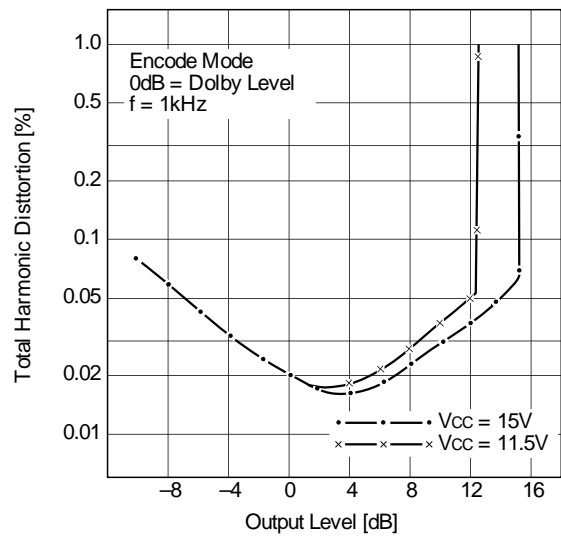

NR off Total Harmonic Distortion-3 (CXA1101)

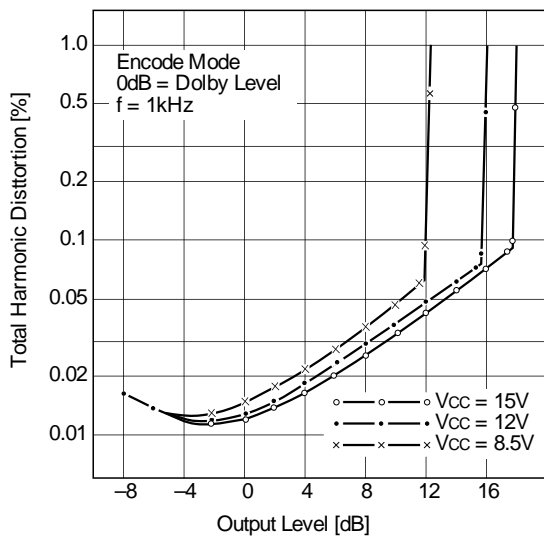

NR on Total Harmonic Distortion-3 (CXA1101)

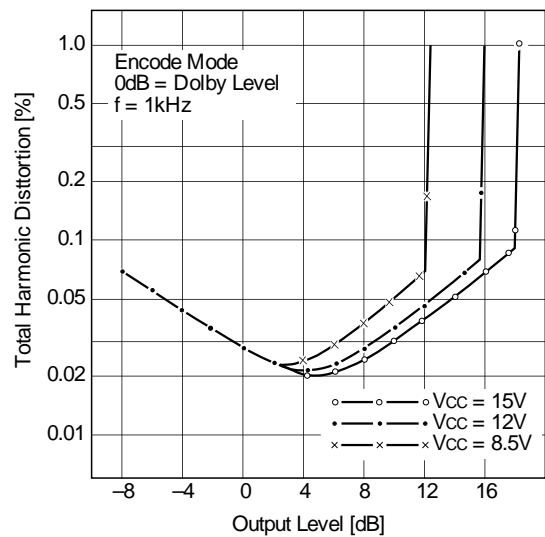

NR off Total Harmonic Distortion-4 (CXA1102)

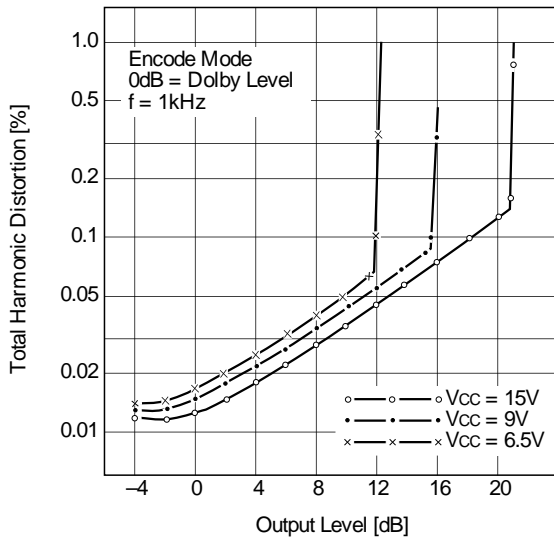

NR on Total Harmonic Distortion-4 (CXA1102)

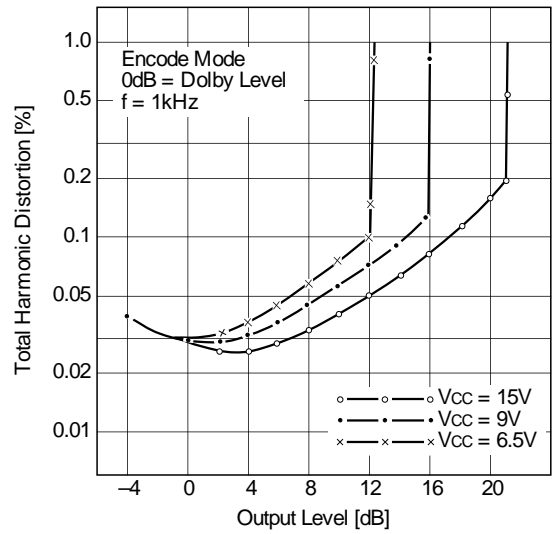

NR off Total Harmonic Distortion-5 (CXA1163)

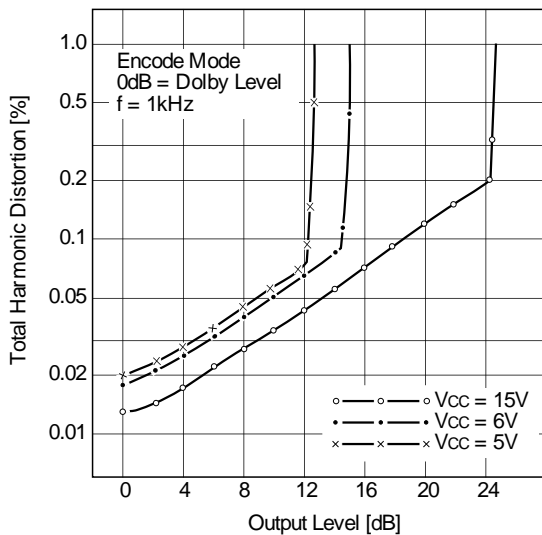

NR on Total Harmonic Distortion-5 (CXA1163)

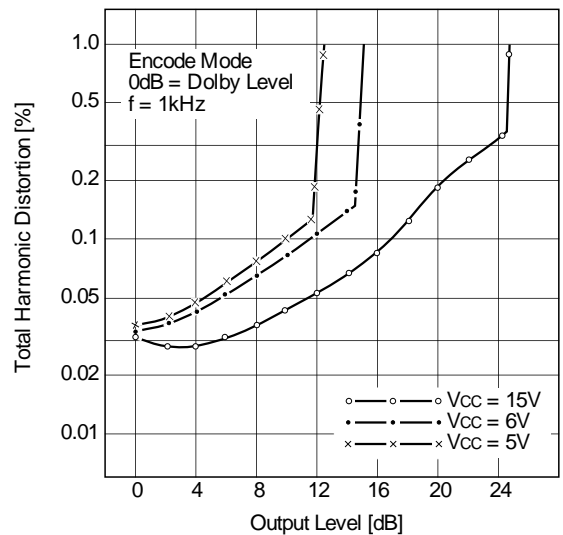

Channel to Channel Crosstalk (CXA1101)

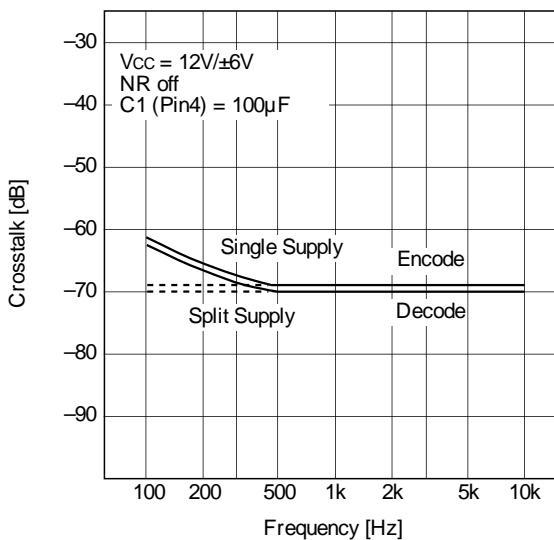

REC to PB and PB to REC Crosstalk (CXA1101)

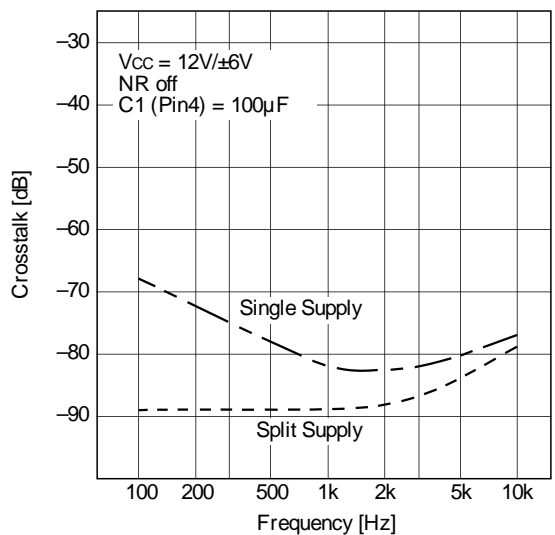

Ripple Rejection Ratio-1 (CXA1101)

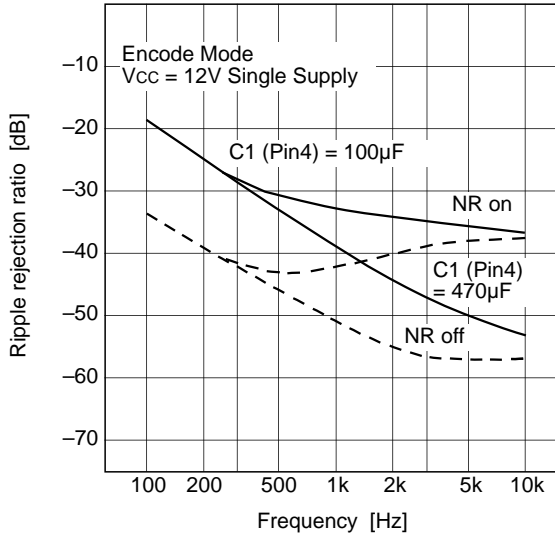

Ripple Rejection Ratio-2 (CXA1101)

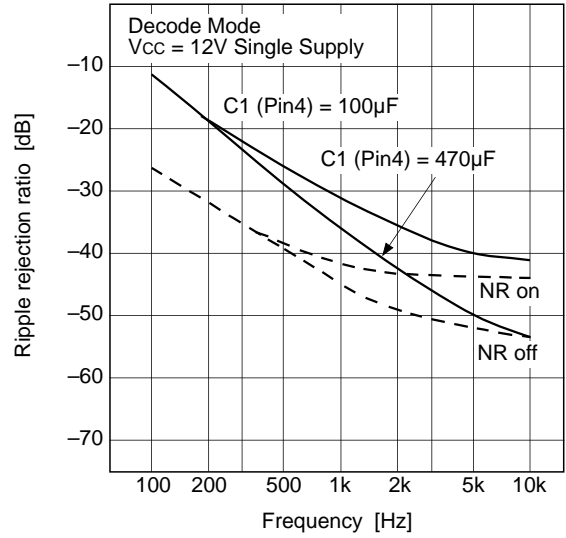

Ripple Rejection Ratio-3 (CXA1101)

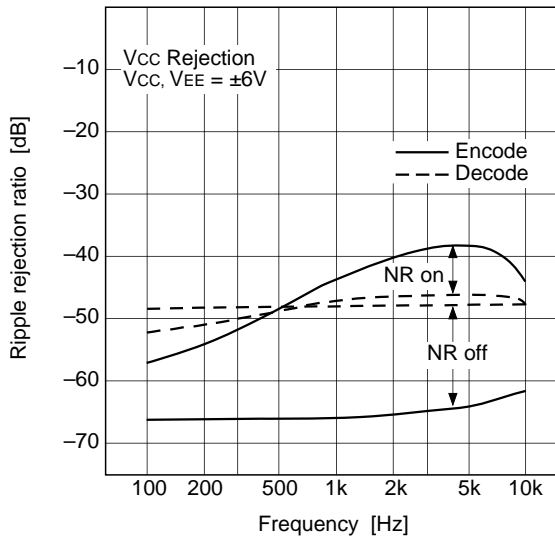

Ripple Rejection Ratio-4 (CXA1101)

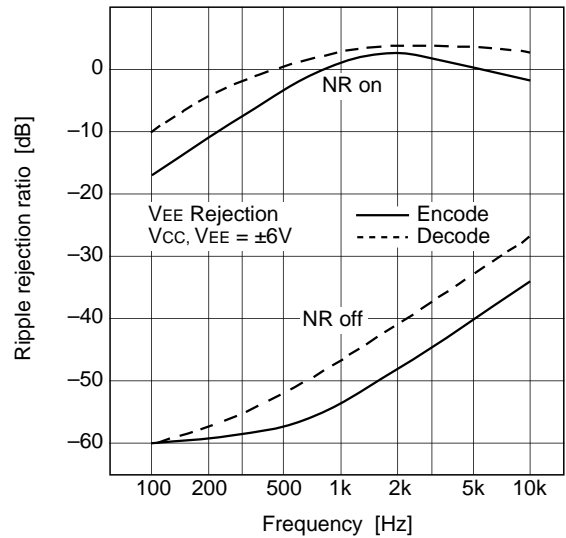

Notes on Applications

1) Power supply

The CXA1100 Series is basically designed to operate on single ended supply. The split supply operation is also possible, however, V_{EE} (negative) supply should provide low noise and ripple characteristics. The ripple rejection ratio of these devices is generally good for V_{CC} supply (single ended supply and split supply), however, that for V_{EE} supply is not so good in the NR on mode because the integrated capacitors for the side chain filter are connected to pin 15 (V_{EE} on split supply).

When the ripple or noise component of V_{EE} supply is not negligible small, the CR filter shown in Fig. a-1 will be useful.

The operation voltage range are

| | |
|---------|--|
| CXA1100 | 11.5 to 16V (± 5.75 to ± 8 V) |
| CXA1101 | 8.5 to 16V (± 4.25 to ± 8 V) |
| CXA1102 | 6.5 to 16V (± 3.25 to ± 8 V) |
| CXA1163 | 5.0 to 16V (± 2.5 to ± 8 V) |

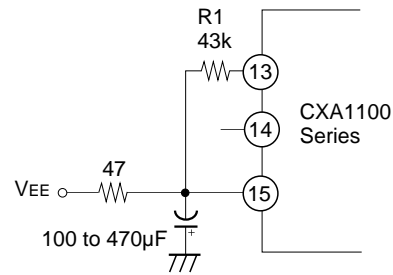

Fig. a-1.

The devices will satisfy the signal handling of 12dB specified by Dolby Laboratories on above voltage range.

2) Operation mode control

The CXA1100 series provide fully electronic switching circuits. The functions are controlled by DC voltages of the two control pins of REC/PB (pin 12) and ON/OFF (pin 5). The switching truth tables are shown in Fig. a-2.

V_H and V_L are defined as

(a) Single ended supply operation

$$V_{CC} \geq V_H \geq 2.5V$$

$$0.5V \geq V_L \geq 0V$$

(b) Split supply operation

$$V_{CC} \geq V_H \geq V_{EE} + 2.5V$$

$$V_{EE} + 0.5V \geq V_L \geq V_{EE}$$

| | | |
|----------|-------------|--------------|
| REC/PB | V_H | V_L |
| Function | PB (Decode) | REC (Encode) |

| | | |
|----------|--------|-------|
| ON/OFF | V_H | V_L |
| Function | NR off | NR on |

Fig. a-2.

It is desirable to provide CR time constant circuits at the mode control pins with time constant from 100msec to 1sec, which will reduce switching clicks effectively.

3) Reference levels

Characteristics and specifications of the Dolby noise reduction processor are defined as the levels and measured with reference to the Dolby level. This particular level in these devices is -10 dBm (245mVrms), and is measured at the recording output (REC OUT) in the NR off mode.

The reference levels of the recording input (REC IN), play back input (PB IN) and line output (LINE OUT) are defined the levels which provide the Dolby level at the recording output in the NR off mode.

The CXA1100 series has a common silicon die, and has different internal connection. The series provides four different line output levels for various applications. Other reference levels, recording input level, playback input level and recording output level (= Dolby level) are identical in all devices.

The reference levels are as follows

| | | |
|--|---------|-----------------------|
| Recording output level (= Dolby level) | | -10 dBm (245mVrms) |
| Recording input level | | -30 dBm (24.5mVrms) |
| Play back input level | | -30 dBm (24.5mVrms) |
| Line output level | CXA1100 | 0dBm (775mVrms) |
| | CXA1101 | -3 dBm (548mVrms) |
| | CXA1102 | -6 dBm (388mVrms) |
| | CXA1163 | -10 dBm (245mVrms) |

4) MPX filter termination and C₁ for V_{cc}/2 (Pin 4)

The MPX (multiplex) filter termination method shown in Fig. a-3 allows saving the coupling capacitors between the buffer amplifiers and MPX filters. However, the channel to channel separation and REC to PB crosstalk of low frequency signals will be degraded by the termination resistor R_T. For example, 5kΩ of R₁ will degrade the channel to channel separation to 50dB. Better separation can be obtained by increasing the capacitance of C₁ (Pin 4) to 220μF or 470μF.

The allowable minimum value of C₁ is 47μF, and 100μF is the standard recommended value. Larger values of C₁ are generally desirable in order to improve the crosstalk and ripple rejection ratio.

5) Application for dubbing cassette decks

The CXA1100 series generates non decoded signal at the recoding output in the decode mode, and can simplify the structure of dubbing decks. See the SONY' Dolby B/C type IC (CX20187/CXA1097Q or CX20188/CXA1098Q) data sheet in detail.

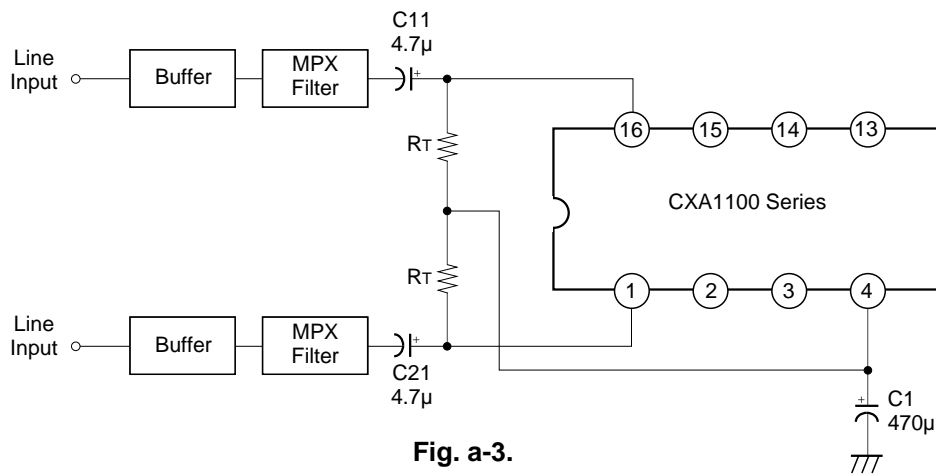
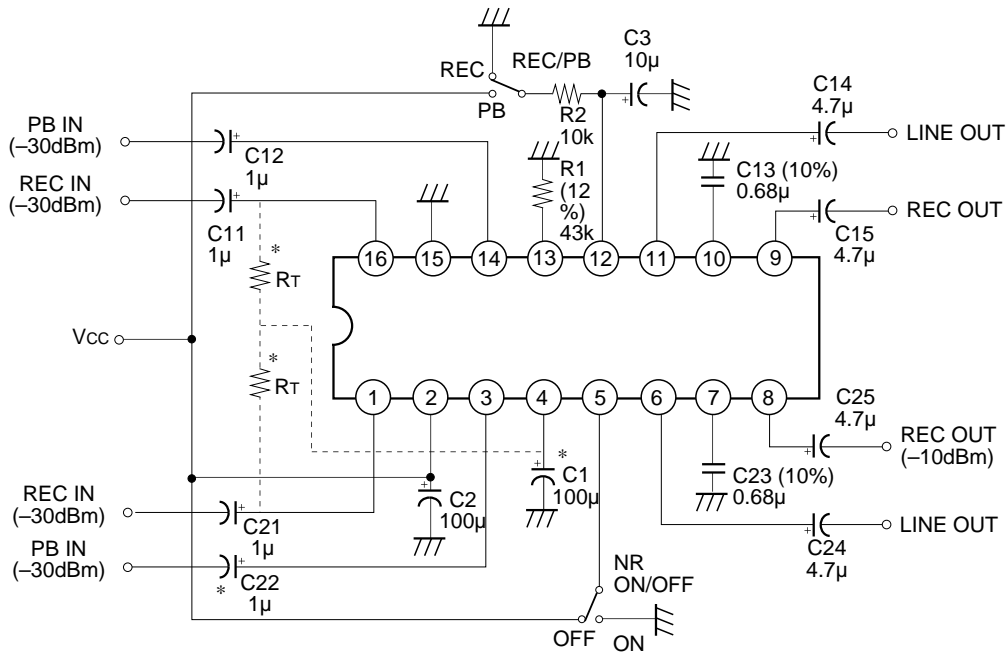

Fig. a-3.

Switchable Processor with Single Supply



Note 1) Resistor and capacitor tolerances are ±10% and ±20% respectively unless otherwise specified.

Note 2) When resistors R_T are connected to Pin 4 for the MPX filter termination, increase the capacitances of C₁ and C₁₁ (C₂₁) to 470μF and 4.7μF respectively.

Switchable Processor with Split Supply

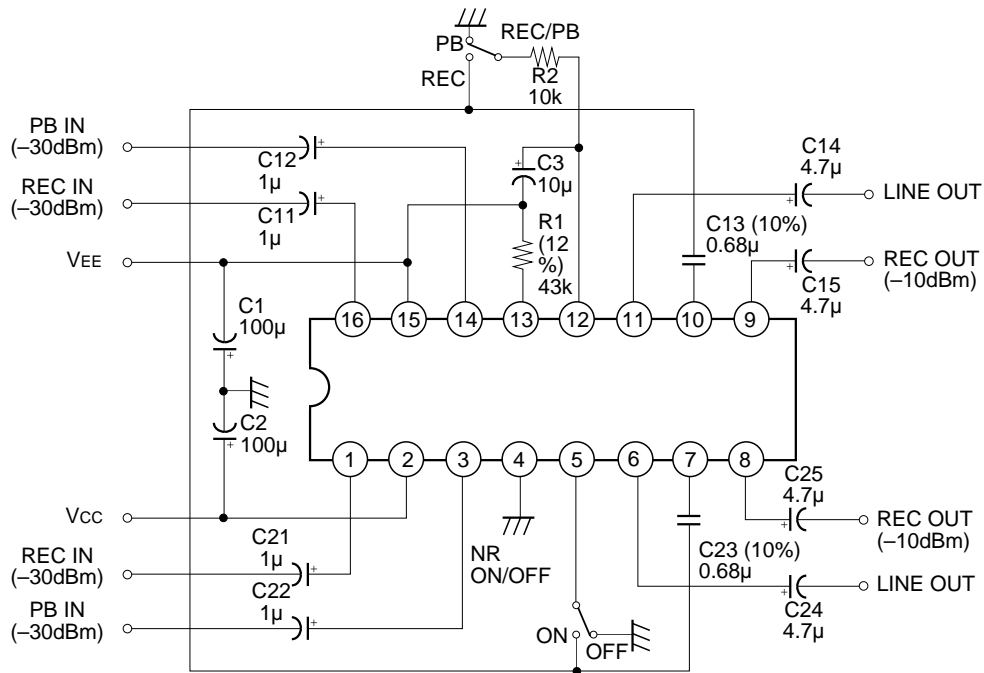

Note 1) Resistor and capacitor tolerances are $\pm 10\%$ and $\pm 20\%$ respectively unless otherwise specified.

Playback Processor with AUX input

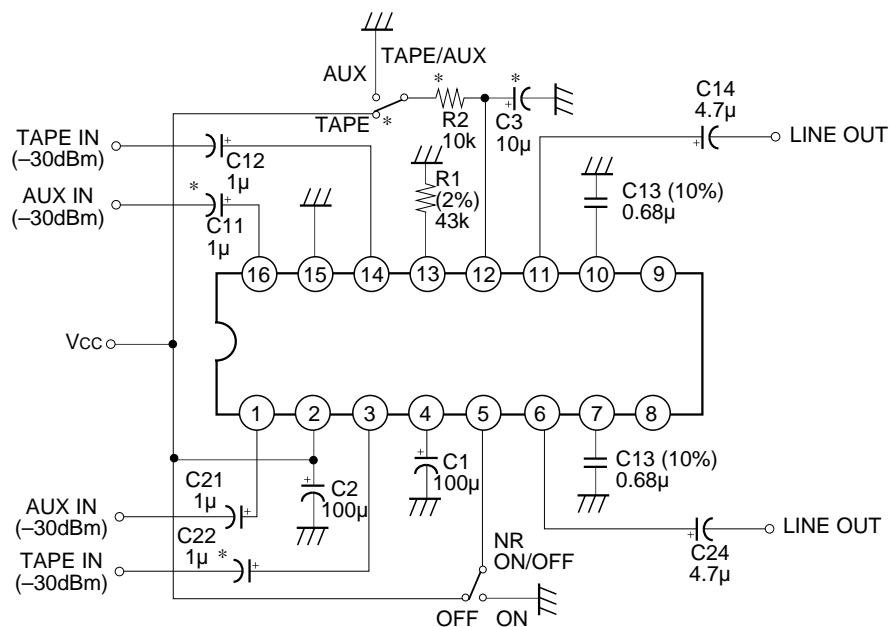

Note 1) Resistor and capacitor tolerances are $\pm 10\%$ and $\pm 20\%$ respectively unless otherwise specified.

Note 2) When AUX inputs are not necessary, reject R₂, C₃, C₁₁, C₂₁ and TAPE/AUX switch, and connect Pin 12 to Vcc.

CXA1100P, CXA1101P/M, CXA1102P/M, CXA1163P/M

16PIN SOP (PLASTIC) 300mil

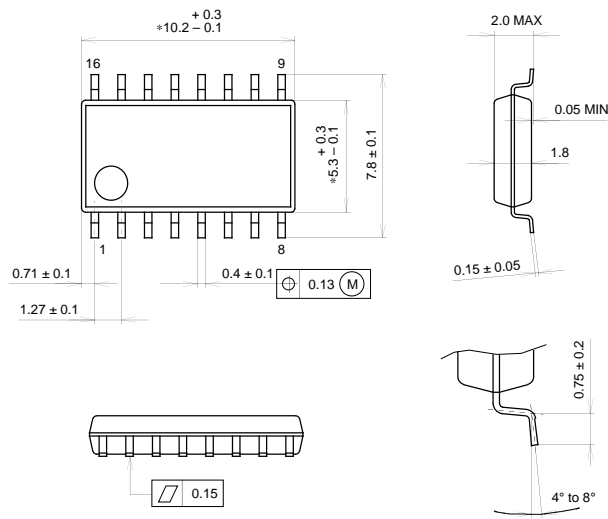

NOTE: Dimension "*" does not include mold protrusion.

PACKAGE STRUCTURE

| | |
|------------|------------------|
| SONY CODE | SOP-16P-L122 |
| EIAJ CODE | SOP016-P-0300-BX |
| JEDEC CODE | _____ |

| | |
|------------------|----------------|
| PACKAGE MATERIAL | EPOXY RESIN |
| LEAD TREATMENT | SOLDER PLATING |
| LEAD MATERIAL | COPPER |
| PACKAGE WEIGHT | 0.21g |

This datasheet has been downloaded from:

www.DatasheetCatalog.com

Datasheets for electronic components.



LittleDiode supplies new, hard to find or obsolete electronic components and semiconductors all over the world.

With over two million different components listed you are sure to find the part you need.

Feel free to visit us today at our online store:

LittleDiode.com

Looking forward to providing you with the best possible service.