

54F/74F151A 8-Input Multiplexer

General Description

The 'F151A is a high-speed 8-input digital multiplexer. It provides in one package the ability to select one line of data from up to eight sources. The 'F151A can be used as a

universal function generator to generate any logic function of four variables. Both assertion and negation outputs are provided.

Commercial	Military	Package Number	Package Description
74F151APC		N16E	16-Lead (0.300" Wide) Molded Dual-In-Line
	54F151ADM (Note 2)	J16A	16-Lead Ceramic Dual-In-Line
74F151ASC (Note 1)		M16A	16-Lead (0.150" Wide) Molded Small Outline, JEDEC
74F151ASJ (Note 1)		M16D	16-Lead (0.300" Wide) Molded Small Outline, EIAJ
	54F151AFM (Note 2)	W16A	16-Lead Cerpack
	54F151ALM (Note 2)	E20A	20-Lead Ceramic Leadless Chip Carrier, Type C

Note 1: Devices also available in 13" reel. Use suffix = SCX and SJX.

Note 2: Military grade device with environmental and burn-in processing. Use suffix = DQMB, FMQB and LMQB.

Logic Symbols

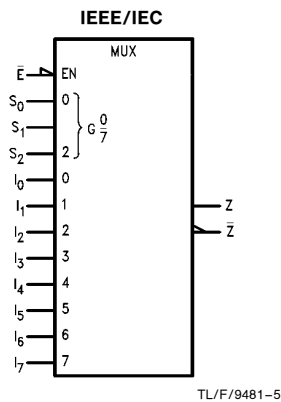
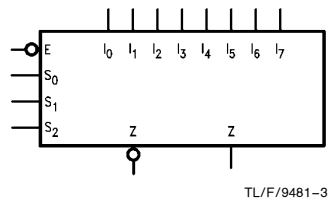

Connection Diagrams

Pin Assignment for DIP, SOIC and Flatpak

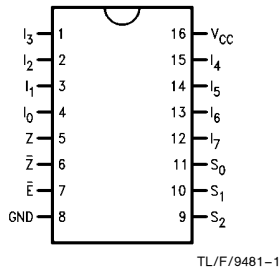

Pin Assignment for LCC

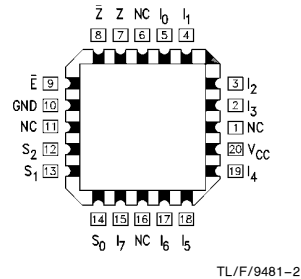

TRI-STATE® is a registered trademark of National Semiconductor Corporation.

Unit Loading/Fan Out

Pin Names	Description	54F/74F	
		U.L. HIGH/LOW	Input I _H /I _L Output I _O H/I _O L
I ₀ -I ₇	Data Inputs	1.0/1.0	20 μA/ -0.6 mA
S ₀ -S ₂	Select Inputs	1.0/1.0	20 μA/ -0.6 mA
\bar{E}	Enable Input (Active LOW)	1.0/1.0	20 μA/ -0.6 mA
Z	Data Output	50/33.3	-1 mA/20 mA
\bar{Z}	Inverted Data Output	50/33.3	-1 mA/20 mA

Functional Description

The 'F151A is a logic implementation of a single pole, 8-position switch with the switch position controlled by the state of three Select inputs, S₀, S₁, S₂. Both assertion and negation outputs are provided. The Enable input (\bar{E}) is active LOW. When it is not activated, the negation output is HIGH and the assertion output is LOW regardless of all other inputs. The logic function provided at the output is:

$$Z = \bar{E} \cdot (I_0 \bar{S}_2 \bar{S}_1 \bar{S}_0 + I_1 \bar{S}_2 \bar{S}_1 S_0 + I_2 \bar{S}_2 S_1 \bar{S}_0 + I_3 \bar{S}_2 S_1 S_0 + I_4 S_2 \bar{S}_1 \bar{S}_0 + I_5 S_2 \bar{S}_1 S_0 + I_6 S_2 S_1 \bar{S}_0 + I_7 S_2 S_1 S_0)$$

The 'F151A provides the ability, in one package, to select from eight sources of data or control information. By proper manipulation of the inputs, the 'F151A can provide any logic function of four variables and its negation.

Truth Table

Inputs				Outputs	
\bar{E}	S ₂	S ₁	S ₀	\bar{Z}	Z
H	X	X	X	H	L
L	L	L	L	\bar{I}_0	I ₀
L	L	L	H	\bar{I}_1	I ₁
L	L	H	L	\bar{I}_2	I ₂
L	L	H	H	\bar{I}_3	I ₃
L	H	L	L	\bar{I}_4	I ₄
L	H	L	H	\bar{I}_5	I ₅
L	H	H	L	\bar{I}_6	I ₆
L	H	H	H	\bar{I}_7	I ₇

H = HIGH Voltage Level
L = LOW Voltage Level
X = Immaterial

Logic Diagram

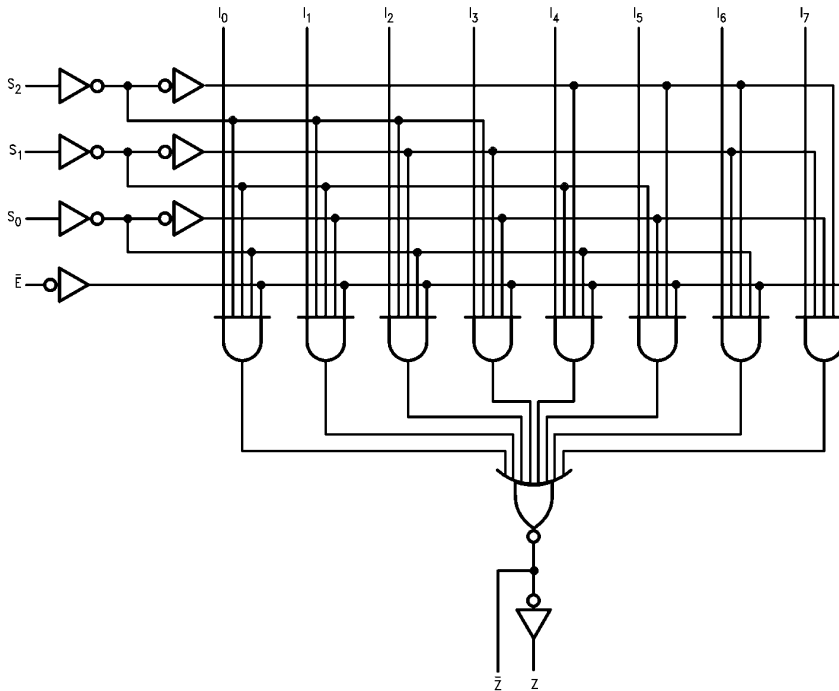

Please note that this diagram is provided only for the understanding of logic operations and should not be used to estimate propagation delays.

TL/F/9481-4

Absolute Maximum Ratings (Note 1)

If Military/Aerospace specified devices are required, please contact the National Semiconductor Sales Office/Distributors for availability and specifications.

Storage Temperature	-65°C to +150°C
Ambient Temperature under Bias	-55°C to +125°C
Junction Temperature under Bias	-55°C to +175°C
Plastic	-55°C to +150°C
V _{CC} Pin Potential to Ground Pin	-0.5V to +7.0V
Input Voltage (Note 2)	-0.5V to +7.0V
Input Current (Note 2)	-30 mA to +5.0 mA
Voltage Applied to Output in HIGH State (with V _{CC} = 0V)	
Standard Output	-0.5V to V _{CC}
TRI-STATE® Output	-0.5V to +5.5V

Current Applied to Output in LOW State (Max) twice the rated I_{OL} (mA)

Note 1: Absolute maximum ratings are values beyond which the device may be damaged or have its useful life impaired. Functional operation under these conditions is not implied.

Note 2: Either voltage limit or current limit is sufficient to protect inputs.

Recommended Operating Conditions

Free Air Ambient Temperature	
Military	-55°C to +125°C
Commercial	0°C to +70°C
Supply Voltage	
Military	+4.5V to +5.5V
Commercial	+4.5V to +5.5V

DC Electrical Characteristics

Symbol	Parameter	54F/74F			Units	V _{CC}	Conditions
		Min	Typ	Max			
V _{IH}	Input HIGH Voltage	2.0			V		Recognized as a HIGH Signal
V _{IL}	Input LOW Voltage			0.8	V		Recognized as a LOW Signal
V _{CD}	Input Clamp Diode Voltage			-1.2	V	Min	I _{IN} = -18 mA
V _{OH}	Output HIGH Voltage	54F 10% V _{CC}	2.5		V	Min	I _{OH} = -1 mA I _{OH} = -1 mA I _{OH} = -1 mA
		74F 10% V _{CC}	2.5				
		74F 5% V _{CC}	2.7				
V _{OL}	Output LOW Voltage	54F 10% V _{CC}		0.5	V	Min	I _{OL} = 20 mA I _{OL} = 20 mA
		74F 10% V _{CC}		0.5			
I _{IH}	Input HIGH Current	54F		20.0	μA	Max	V _{IN} = 2.7V
		74F		5.0			
I _{BVI}	Input HIGH Breakdown Current	54F		100	μA	Max	V _{IN} = 7.0V
		74F		7.0			
I _{CEX}	Output HIGH Leakage Current	54F		250	μA	Max	V _{OUT} = V _{CC}
		74F		50			
V _{ID}	Input Leakage Test	74F	4.75		V	0.0	I _{ID} = 1.9 μA All Other Pins Grounded
I _{OD}	Output Leakage Circuit Current	74F		3.75	μA	0.0	V _{IOD} = 150 mV All Other Pins Grounded
I _{IL}	Input LOW Current			-0.6	mA	Max	V _{IN} = 0.5V
I _{OS}	Output Short-Circuit Current			-60	mA	Max	V _{OUT} = 0V
I _{CC}	Power Supply Current		13.5	21.0	mA	Max	V _O = HIGH

AC Electrical Characteristics

Symbol	Parameter	74F			54F		74F		Units
		T _A = +25°C V _{CC} = +5.0V C _L = 50 pF			T _A , V _{CC} = Mil C _L = 50 pF		T _A , V _{CC} = Com C _L = 50 pF		
		Min	Typ	Max	Min	Max	Min	Max	
t _{PLH} t _{PHL}	Propagation Delay S _n to \bar{Z}	4.0 3.2	6.2 5.2	9.0 7.5	3.5 3.0	11.5 8.0	3.5 3.2	9.5 7.5	ns
t _{PLH} t _{PHL}	Propagation Delay S _n to Z	4.5 4.0	7.5 6.2	10.5 9.0	4.5 4.0	13.5 9.5	4.5 4.0	12.0 9.0	ns
t _{PLH} t _{PHL}	Propagation Delay \bar{E} to \bar{Z}	3.0 3.0	4.7 4.4	6.1 6.0	3.0 2.5	7.5 6.5	3.0 2.5	7.0 6.0	ns
t _{PLH} t _{PHL}	Propagation Delay \bar{E} to Z	5.0 3.5	7.0 5.3	9.5 7.0	4.0 3.0	12.0 8.0	4.0 3.0	10.5 7.5	ns
t _{PLH} t _{PHL}	Propagation Delay I _n to \bar{Z}	3.0 1.5	4.8 2.5	6.5 4.0	2.5 1.5	7.5 6.0	3.0 1.5	7.0 5.0	ns
t _{PLH} t _{PHL}	Propagation Delay I _n to Z	3.0 3.7	4.8 5.5	6.5 7.0	2.5 3.5	8.5 9.0	2.5 3.7	7.5 7.5	ns

Ordering Information

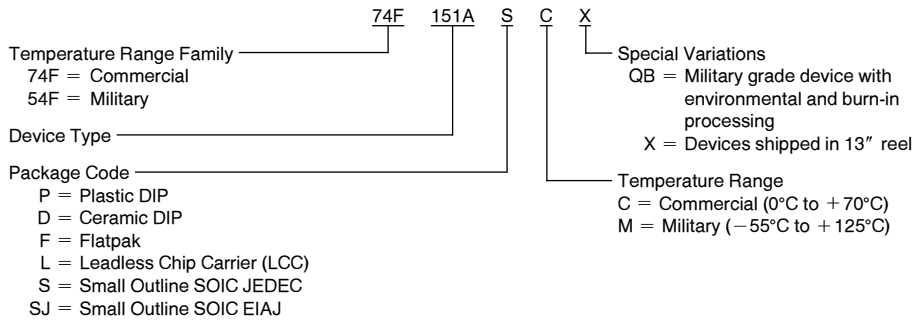

Physical Dimensions inches (millimeters)

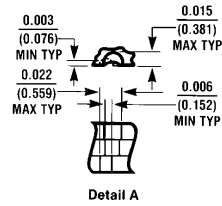
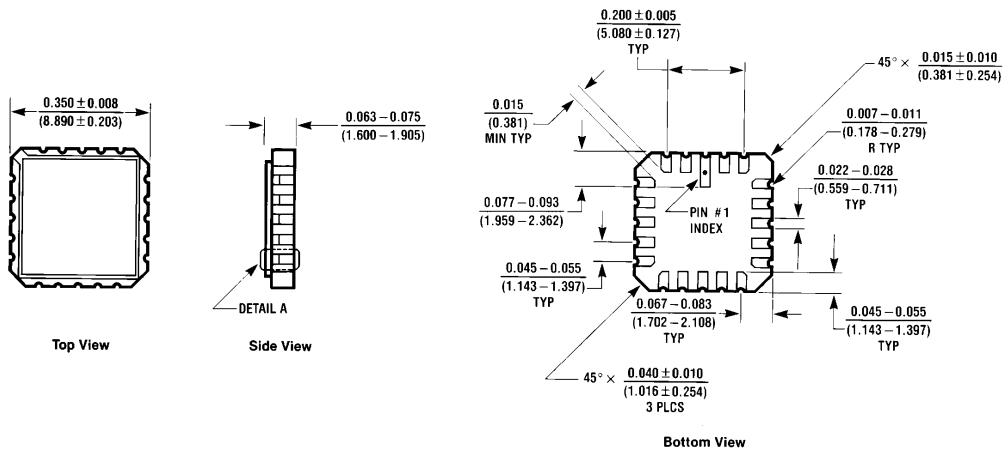

20-Lead Ceramic Leadless Chip Carrier (L)
 NS Package Number E20A

E20A (REV D)

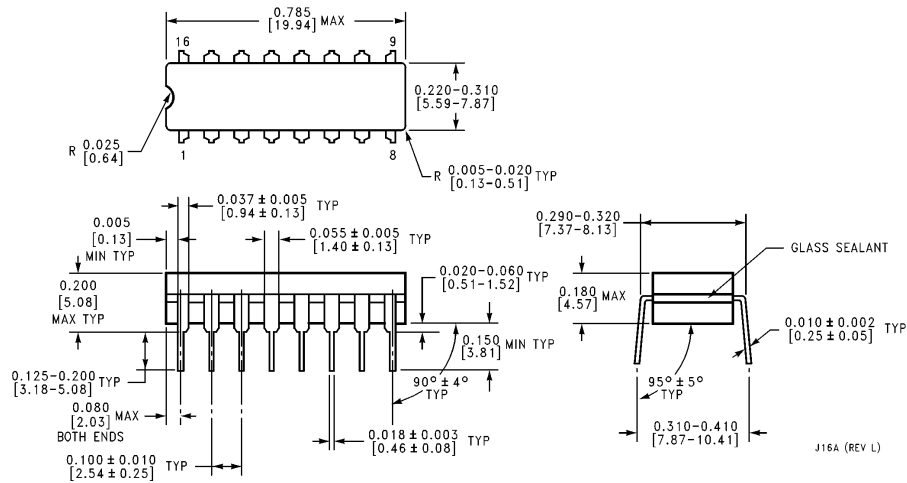

16-Lead Ceramic Dual In-Line Package (D)
 NS Package Number J16A

J16A (REV L)

Physical Dimensions inches (millimeters) (Continued)

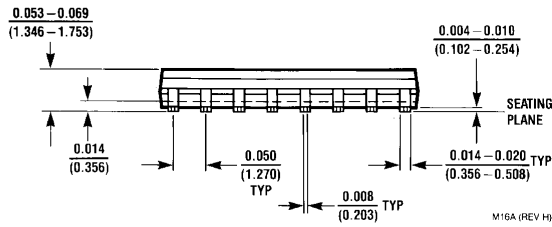
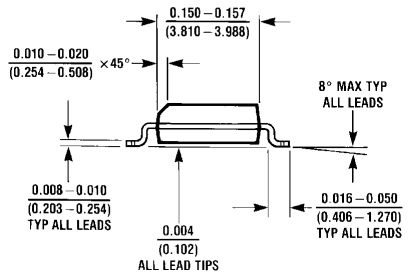
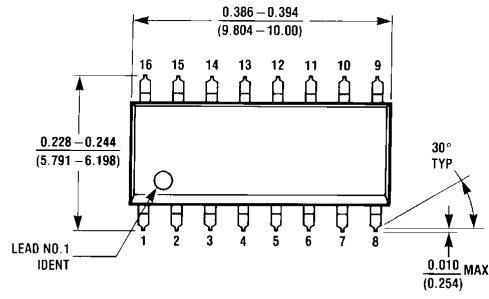

**16-Lead (0.150" Wide) Molded Small Outline Package, JEDEC (S)
NS Package Number M16A**

M16A (REV H)

Physical Dimensions inches (millimeters) (Continued)

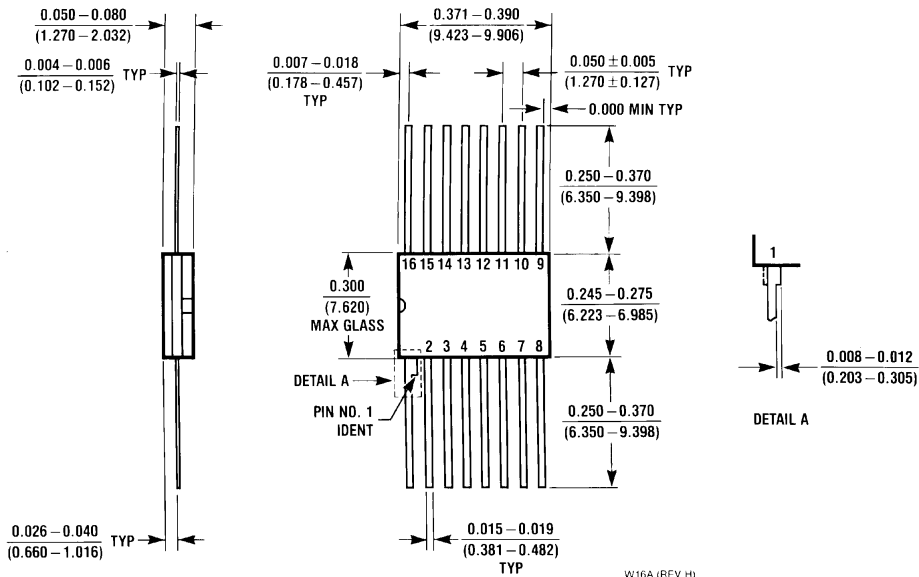

**16-Lead Ceramic Flatpak (F)
NS Package Number W16A**

LIFE SUPPORT POLICY

NATIONAL'S PRODUCTS ARE NOT AUTHORIZED FOR USE AS CRITICAL COMPONENTS IN LIFE SUPPORT DEVICES OR SYSTEMS WITHOUT THE EXPRESS WRITTEN APPROVAL OF THE PRESIDENT OF NATIONAL SEMICONDUCTOR CORPORATION. As used herein:

1. Life support devices or systems are devices or systems which, (a) are intended for surgical implant into the body, or (b) support or sustain life, and whose failure to perform, when properly used in accordance with instructions for use provided in the labeling, can be reasonably expected to result in a significant injury to the user.
2. A critical component is any component of a life support device or system whose failure to perform can be reasonably expected to cause the failure of the life support device or system, or to affect its safety or effectiveness.



National Semiconductor Corporation
1111 West Bardin Road
Arlington, TX 76017
Tel: 1(800) 272-9959
Fax: 1(800) 737-7018

National Semiconductor Europe
Fax: (+49) 0-180-530 85 86
Email: cnjwge@tevm2.nsc.com
Deutsch Tel: (+49) 0-180-530 85 85
English Tel: (+49) 0-180-532 78 32
Français Tel: (+49) 0-180-532 93 58
Italiano Tel: (+49) 0-180-534 16 80

National Semiconductor Hong Kong Ltd.
13th Floor, Straight Block,
Ocean Centre, 5 Canton Rd.
Tsimshatsui, Kowloon
Hong Kong
Tel: (852) 2737-1600
Fax: (852) 2736-9960

National Semiconductor Japan Ltd.
Tel: 81-043-299-2309
Fax: 81-043-299-2408

National does not assume any responsibility for use of any circuitry described, no circuit patent licenses are implied and National reserves the right at any time without notice to change said circuitry and specifications.

National Semiconductor was acquired by Texas Instruments.

http://www.ti.com/corp/docs/investor_relations/pr_09_23_2011_national_semiconductor.html

This file is the datasheet for the following electronic components:

54F151ADMQB - <http://www.ti.com/product/54f151admqb?HQS=TI-null-null-dscatalog-df-pf-null-wwe>

54F151AFMQB - <http://www.ti.com/product/54f151afmqb?HQS=TI-null-null-dscatalog-df-pf-null-wwe>

54F151ALMQB - <http://www.ti.com/product/54f151almqb?HQS=TI-null-null-dscatalog-df-pf-null-wwe>



LittleDiode supplies new, hard to find or obsolete electronic components and semiconductors all over the world.

With over two million different components listed you are sure to find the part you need.

Feel free to visit us today at our online store:

LittleDiode.com

Looking forward to providing you with the best possible service.