

**HOME AUTOMATION MODEM**

- HALF DUPLEX ASYNCHRONOUS 2400bps FSK MODEM
- Tx CARRIER FREQUENCY SYNTHESIZED FROM EXTERNAL CRYSTAL
- LOW DISTORTION Tx SIGNAL
- Rx SENSITIVITY BETTER THAN 1mV<sub>RMS</sub>
- CARRIER DETECTION
- WATCH-DOG INPUT
- RESET AND MASTER CLOCK OUTPUTS FOR MICROCONTROLLER
- POWER AMPLIFIER BIAS CURRENT CONTROL (HIGH IMPEDANCE IN Rx MODE)
- SIMPLE AND ECONOMICAL APPLICATION SCHEMATICS
- COMPATIBLE WITH CENELEC EN 50065-1 AND FCC SPECIFICATION
- CARRIER DETECT CLAMPING ON Rx D PROGRAMMABLE (ALLOWING DEMODULATION ON VERY LOW RECEIVE LEVEL, 1mV<sub>RMS</sub> TYPICALLY)

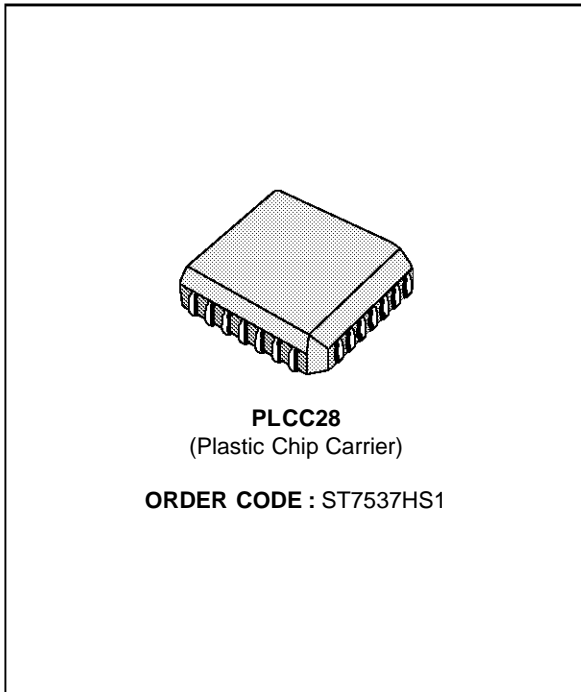

**DESCRIPTION**

The ST7537HS1 is a half duplex asynchronous FSK MODEM designed for home automation communication on the domestic electric mains which complies with the EN 50065-1 CENELEC standard.

It mainly operates from a 10V power supply and a 5V power supply for the microcontroller digital interface.

It is interfaced to the power line by an external driver, and a transformer (see Application Schematic Diagram). Its data transmission rate is 2400 bps and its carrier frequency is 132.45kHz.

**PIN CONNECTIONS**

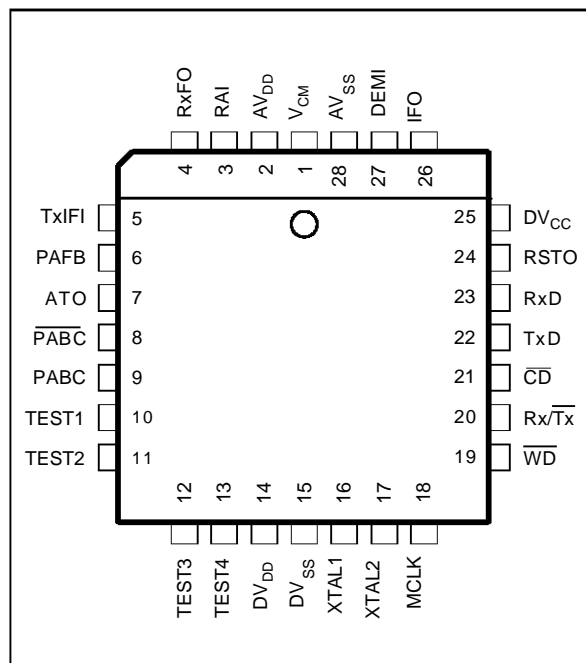

7537H-01.EPS

**PIN DESCRIPTION**

Pin Name	Pin Number	Pin Type	Description
V <sub>CM</sub>	1	Analog	Common Mode Voltage
AV <sub>DD</sub>	2	Supply	Analog Power Supply : 10V ±5 %
RAI	3	Analog	Receive Analog Input
RxFO	4	Analog	Receive Filter Output
TxIFI	5	Analog	Transmit and Intermediate Frequency Filters Test Input (mode TEST3)
PAFB	6	Analog	Power Amplifier Feed-back Input
ATO	7	Analog	Analog Transmit Output
PABC	8	Digital (10V)	Power Amplifier Bias Current Control Complementary Output
PABC	9	Digital (10V)	Power Amplifier Bias Current Control Output
TEST1	10	Digital	Tx to Rx Automatic Mode Switching Control Input
TEST2	11	Digital	Automatic Mode Switching Time and Watch-dog Time Reduction Control Input
TEST3	12	Digital	TxIFI Selection Input
TEST4	13	Digital	Undelayed Reset Input
DV <sub>DD</sub>	14	Supply	Digital Power Supply : 10V ±5%
DV <sub>SS</sub>	15	Supply	Digital Ground : 0V
XTAL1	16	Digital (10V)	Crystal Oscillator Input
XTAL2	17	Digital (10V)	Crystal Oscillator Output
MCLK	18	Digital	Master Clock Output
WD	19	Digital	Watch-dog Input
Rx/Tx	20	Digital	Rx or Tx Mode Selection Input
CD	21	Digital	Carrier Detect Output
TxD	22	Digital	Transmit Data Input
RxD	23	Digital	Receive Data Output
RSTO	24	Digital	Reset Output
DV <sub>CC</sub>	25	Supply	Digital Buffers Supply Voltage : 5V ±5 %
I FO	26	Analog	Intermediate Frequency Filter Output
DEMI	27	Analog	Demodulator Input
AV <sub>SS</sub>	28	Supply	Analog Ground : 0V

7537H-01.TBL

## BLOCK DIAGRAM

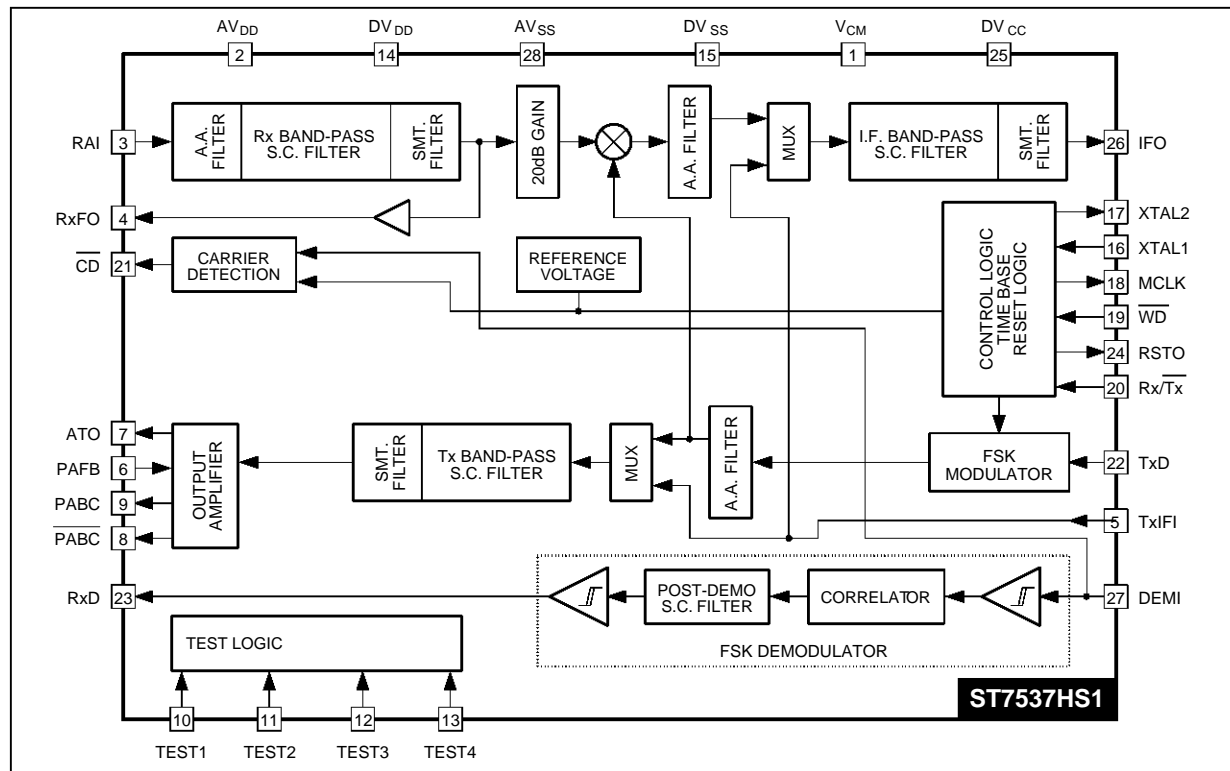

7537H-02.EPS

## TRANSMIT SECTION

The transmit mode is set when  $Rx/\overline{Tx} = 0$ , if  $Rx/\overline{Tx}$  is held at 0 longer than 1 second, then the device switches automatically in the Rx mode. A new activation of the Tx mode requires  $Rx/\overline{Tx}$  to be returned to 1 for a minimum 2 microsecond period before being set to 0.

The Transmit Data (TxD) enter asynchronously the FSK modulator with a nominal intra-message data rate of 2400 bps.

The basic transmit frequencies are :

- $f(TxD=0) = 133.05\text{kHz}$
- $f(TxD=1) = 131.85\text{kHz}$

These frequencies are synthesized from a 11.0592MHz crystal oscillator; their precision is the same as the crystal one's (100ppm).

The modulated signal coming out of the FSK modulator is filtered by a switched-capacitor band-pass filter (Tx band-pass) in order to limit the output spectrum and to reduce the level of harmonic components.

The final stage of the Tx path consists of an operational amplifier which needs a feed-back signal (PAFB) from the power amplifier as shown on Application Schematic Diagram.

In Tx mode the Receive Data (RxD) signal is set to 1.

## RECEIVE SECTION

The receive section is active when  $Rx/\overline{Tx} = 1$ .

The Rx signal is applied on RAI and filtered by a band-pass switched capacitor filter (Rx band-pass) centered on the carrier frequency and whose bandwidth is around 12kHz.

The Rx filter output is amplified by a 20dB gain stage which provides symmetrical limitations for large voltage. The resulting signal is down-converted by a mixer which receives a local oscillator synthesized by the FSK modulator block. Finally an intermediate frequency band-pass filter (IF band-pass) whose central frequency is 5.4kHz improves the signal to noise ratio before entering the FSK demodulator.

The coupling of the intermediate frequency filter output (IFO) to the FSK demodulator input (DEMI) is made by an external capacitor C5 (100nF  $\pm 10\%$ , 10V) which cancels the Rx path offset voltage.

The RxD output delivers the demodulated signal if the carrier detect (CD) signal is low and is set to high level when CD = 1.

The RxD output can deliver the demodulated signal whatever the level of CD (0 or 1) if  $Rx/\overline{Tx} = 1$  and TxD = 0 (see Figure 1).

Figure 1 : Data Timing Chart

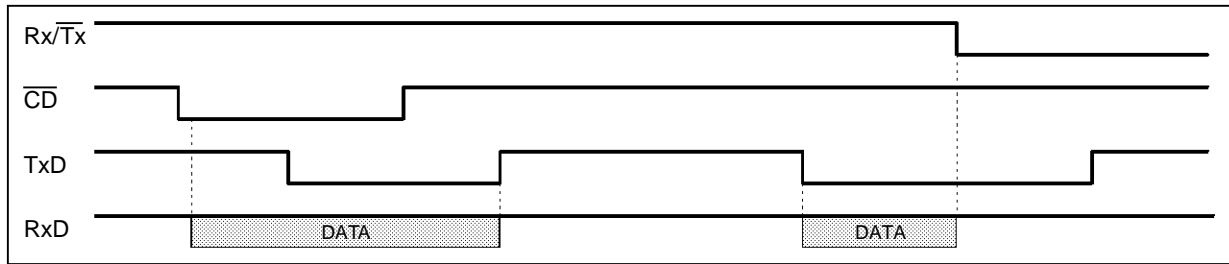

7537H-03.EPS

**ADDITIONAL DIGITAL AND ANALOG FUNCTIONS**

**Time base**

A time base section delivers all the internal clocks from a crystal oscillator (11.0592MHz). The crystal is connected between XTAL1 and XTAL2 pins and needs two external capacitors C3 and C4 (22pF ±10%, 10V) for proper operation.

**Reset and watch-dog**

The reset output (RSTO) is driven high when the supply voltage is lower than Vrh (typically 7.6V) with an hysteresis Vrh-Vrl (typically 300mV) or when no negative transition occurs on the watch-dog input (WD) for more than 1.5 second (see the timing chart on Figure 2). When a reset occurs RSTO is held high for at least 50ms.

**Signal detection**

The Carrier Detect output (CD) is driven low when the input signal amplitude on RAI is greater than VCD for at least TCD (typically 6ms see the timing chart on Figure 3). When the input signal disappears or becomes lower than VCD, CD is held low for at least Tcd before returning to a high level. VCD is the carrier detection threshold voltage which is set internally to detect 5mVRMS typically.

**External power amplifier bias control**

Two dedicated digital output (PABC and PABC) delivering a signal between 0V and 10V are driven

low respectively high, when the circuit is set in the receive mode (Rx/Tx=1) or when the transmit mode time out (1 second) is exceeded; in the same time the output ATO is put in a high impedance state.

**TESTING FEATURES**

- An additional amplifier allows the observation of the Rx band-pass filter output on pin RxFO.
- A direct input to the Tx band-pass filter and to the IF filter (TxIFI) is selected when TEST3 = 1.
- The 1 second normal duration of the Tx to Rx mode automatic switching is reduced to 488µs and the 1.5 second watch-dog time out is reduced to 46.3µs when TEST2 = 1.
- When TEST1 = 1 the Tx to Rx mode automatic switching is deactivated and the functional mode of the circuit is fully controlled by Rx/Tx.
- TEST4 is a reset input which allows an undelayed control of RSTO and of the internal state of the circuit.

**POWER SUPPLIES WIRING PRECAUTIONS**

The ST7537HS1 has two positive power supply terminals (AVDD, DVDD) and two ground terminals (AVSS, DVSS) in order to separate internal analog and digital supplies. The analog and digital terminals of each supply pair must be connected together externally for proper operation.

The VDD must be protected against short-circuit for proper operation.

**ABSOLUTE MAXIMUM RATINGS**

Symbol	Parameter	Value	Unit
AV <sub>DD</sub> /DV <sub>DD</sub>	Supply Voltage (1)	- 0.3, + 12	V
V <sub>I</sub>	Digital Input Voltage	DV <sub>SS</sub> - 0.3, DV <sub>DD</sub> + 0.3	V
V <sub>O</sub>	Digital Output Voltage (microcontroller interface)	DV <sub>SS</sub> - 0.3, DV <sub>CC</sub> + 0.3	V
V <sub>O</sub>	Digital Output Voltage (PABC and $\overline{\text{PABC}}$ )	DV <sub>SS</sub> - 0.3, DV <sub>DD</sub> + 0.3	V
I <sub>O</sub>	Digital Output Current	- 5, + 5	mA
V <sub>I</sub>	Analog Input Voltage	AV <sub>SS</sub> - 0.3, AV <sub>DD</sub> + 0.3	V
V <sub>O</sub>	Analog Output Voltage	AV <sub>SS</sub> - 0.3, AV <sub>DD</sub> + 0.3	V
I <sub>O</sub>	Analog Output Current	- 5, + 5	mA
P <sub>D</sub>	Power Dissipation	500	mW
T <sub>oper</sub>	Operating Temperature	0, + 70	°C
T <sub>stg</sub>	Storage Temperature	- 55, + 150	°C

7537H-02.TBL

- Notes :**
1. The voltages are referenced to AV<sub>SS</sub> and DV<sub>SS</sub>.
  2. Absolute maximum ratings are values beyond which damage to device may occur. Functional operation under these conditions is not implied.

**GENERAL ELECTRICAL CHARACTERISTICS**

(A/DV<sub>DD</sub> = 10V, A/DV<sub>SS</sub> = 0V, DV<sub>CC</sub> = 5V and 0°C ≤ T<sub>amb</sub> ≤ 70°C, unless otherwise specified)

Symbol	Parameter	Test Conditions	Min.	Typ.	Max.	Unit
AV <sub>DD</sub> DV <sub>DD</sub>	Supply Voltage		9.5	10	10.5	V
AI <sub>DD</sub> + DI <sub>DD</sub>	Supply Current			30		mA
DV <sub>CC</sub>	Digital Output Supply Voltage		4.75		5.25	V
DI <sub>CC</sub>	Digital Output Supply Current			1.5		mA
V <sub>IH</sub>	High Level Input Voltage	Digital Inputs	4.2			V
V <sub>IL</sub>	Low Level Input Voltage	Digital Inputs			0.8	V
V <sub>OH</sub>	High Level Output Voltage	I <sub>OH</sub> = -100μA • Digital Outputs • Digital Outputs PABC and $\overline{\text{PABC}}$	4.9 9.8			V V
V <sub>OL</sub>	Low Level Output Voltage	I <sub>OL</sub> = 100μA • Digital Outputs • Digital Outputs PABC and $\overline{\text{PABC}}$			0.1 0.2	V V
DC	Duty Cycle	MCLK Output, C <sub>L</sub> = 15pF	40		60	%

7537H-03.TBL

**TRANSMITTER ELECTRICAL CHARACTERISTICS**

(A/DV<sub>DD</sub> = 10V, A/DV<sub>SS</sub> = 0V, DV<sub>CC</sub> = 5V and 0°C ≤ T<sub>amb</sub> ≤ 70°C, unless otherwise specified)

Symbol	Parameter	Test Conditions	Min.	Typ.	Max.	Unit
VTAC	Max Carrier Output AC Voltage	R <sub>L</sub> = 5.6kΩ R <sub>L</sub> (AV <sub>SS</sub> ) = 5.6kΩ R(ATO, PAFB) = 1kΩ	0.8	1.0	1.3	V <sub>RMS</sub>
HD2	Second Harmonic Distortion			- 50		dB
HD3	Third Harmonic Distortion			- 60		dB
FD	FSK Peak-to-peak Deviation			1200		Hz

7537H-04.TBL

**RECEIVER ELECTRICAL CHARACTERISTICS**

(A/DV<sub>DD</sub> = 10V, A/DV<sub>SS</sub> = 0V, DV<sub>CC</sub> = 5V and 0°C ≤ T<sub>amb</sub> ≤ 70°C, unless otherwise specified)

Symbol	Parameter	Test Conditions	Min.	Typ.	Max.	Unit
V <sub>IN</sub>	Input Sensitivity			1	10	mV <sub>RMS</sub>
V <sub>IN</sub>	Maximum Input Signal				2	V <sub>RMS</sub>
R <sub>IN</sub>	Input Impedance		15			kΩ
GR <sub>X</sub>	Receive Gain	f = 132.45kHz		20		dB
BER	Bit Error Rate (1)	S/N = 15dB, S = 10mV <sub>RMS</sub> , N : white		10 <sup>-5</sup>	10 <sup>-3</sup>	
t <sub>DEM</sub>	Demodulation Time	Alternate 0 , 1 sequence		3		T bit
V <sub>CD</sub>	Carrier Detection Level	f = 132.45kHz, sine wave		5	10	mV <sub>RMS</sub>

Note 1 : This parameter is guaranteed by correlation

**ADDITIONAL DIGITAL AND ANALOG FUNCTIONS ELECTRICAL CHARACTERISTICS**

(A/DV<sub>DD</sub> = 10V, A/DV<sub>SS</sub> = 0V, DV<sub>CC</sub> = 5V and 0°C ≤ T<sub>amb</sub> ≤ 70°C, unless otherwise specified)

Symbol	Parameter	Test Conditions	Min.	Typ.	Max.	Unit
V <sub>RH</sub>	High Level Reset Voltage	See Figure 2		7.9		V
V <sub>RL</sub>	Low Level Reset Voltage	See Figure 2		7.6		V
t <sub>RST</sub>	Reset Time	See Figure 2	50			ms
t <sub>WD</sub>	Watch-dog Pulse Width	See Figure 2	500			ns
t <sub>WM</sub>	Watch-dog Pulse Period	See Figure 2	800			μs
t <sub>OUT</sub>	Watch-dog Time Out	See Figure 2			1.5	s
t <sub>CD</sub>	Carrier Detection Time	See Figure 3	3		6.5	ms

Figure 2 : Reset and Watch-dog Timing Chart

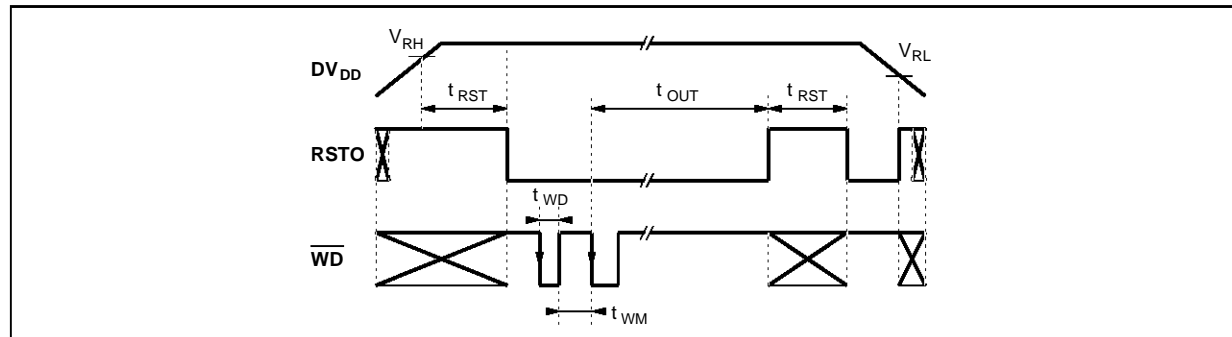
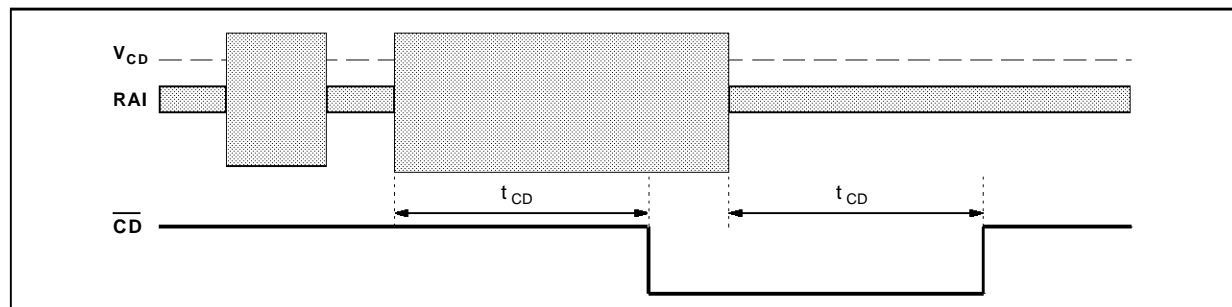

Figure 3 : Carrier Detection Timing Chart



## FILTER TEMPLATES

## Receive and Transmit Filter

Frequency (kHz)	Gain (dB)		
	Min.	Typ.	Max.
92			- 30
126.45	- 5	- 3	- 2
Ref 132.45		0	
138.45	- 5	- 3	- 2
180			- 30

## Intermediate Frequency Filter

Frequency (kHz)	Gain (dB)		
	Min.	Typ.	Max.
2.4			- 35
4.3	- 4	- 3	- 1
Ref 5.4		0	
6.5	- 5	- 3	- 2
11.6			- 35

7537H-07.TBL

## APPLICATION SCHEMATIC INFORMATIONS

RESISTORS			CAPACITORS			
R1	180Ω		C1	1μF		Ceramic 50
R2	2.2Ω		C2	470nF		Paper, class X2
R3	2.2Ω		C3 (2)	22pF	10%	Ceramic 10V
R4	2.2Ω		C4 (2)	22pF	10%	Ceramic 10V
R5	2.2Ω		C5	100nF	10%	Ceramic 10V
R6	180Ω		C6	6.8nF	5%	Plastic Film 50V
R7	47kΩ		C7	100nF		Ceramic 10V
R8	1kΩ		C8	2.2μF		
R9	1kΩ	5%	C9	100nF		Ceramic 10V
R11	47kΩ		C10	2.2μF		
<b>INDUCTOR</b>			C11 (1)	100nF		Ceramic 10V
L1	10μH	≅ 1.5Ω	C12 (1)	100nF		Ceramic 10V
TRANSISTORS			TRANSIL			
Q1 : 2N2907 Q2 : 2N2222 Q3 : 2N2222 Q4 : 2N2907 Q5 : 2N2907 Q6 : 2N2222			TRL1 : SGS-THOMSON P6KE6V8CP			
			TRANSFORMER			
			TR1 : TOKO T1002 N			
			CRYSTAL			
			QTZ1 : 11.0592MHz parallel resonance			

7537H-08.TBL

- Notes :**
1. These capacitors might not be necessary if the overall power supplies decoupling is sufficient.
  2. The value of these capacitors depends on the crystal parameters.

APPLICATION SCHEMATIC DIAGRAM

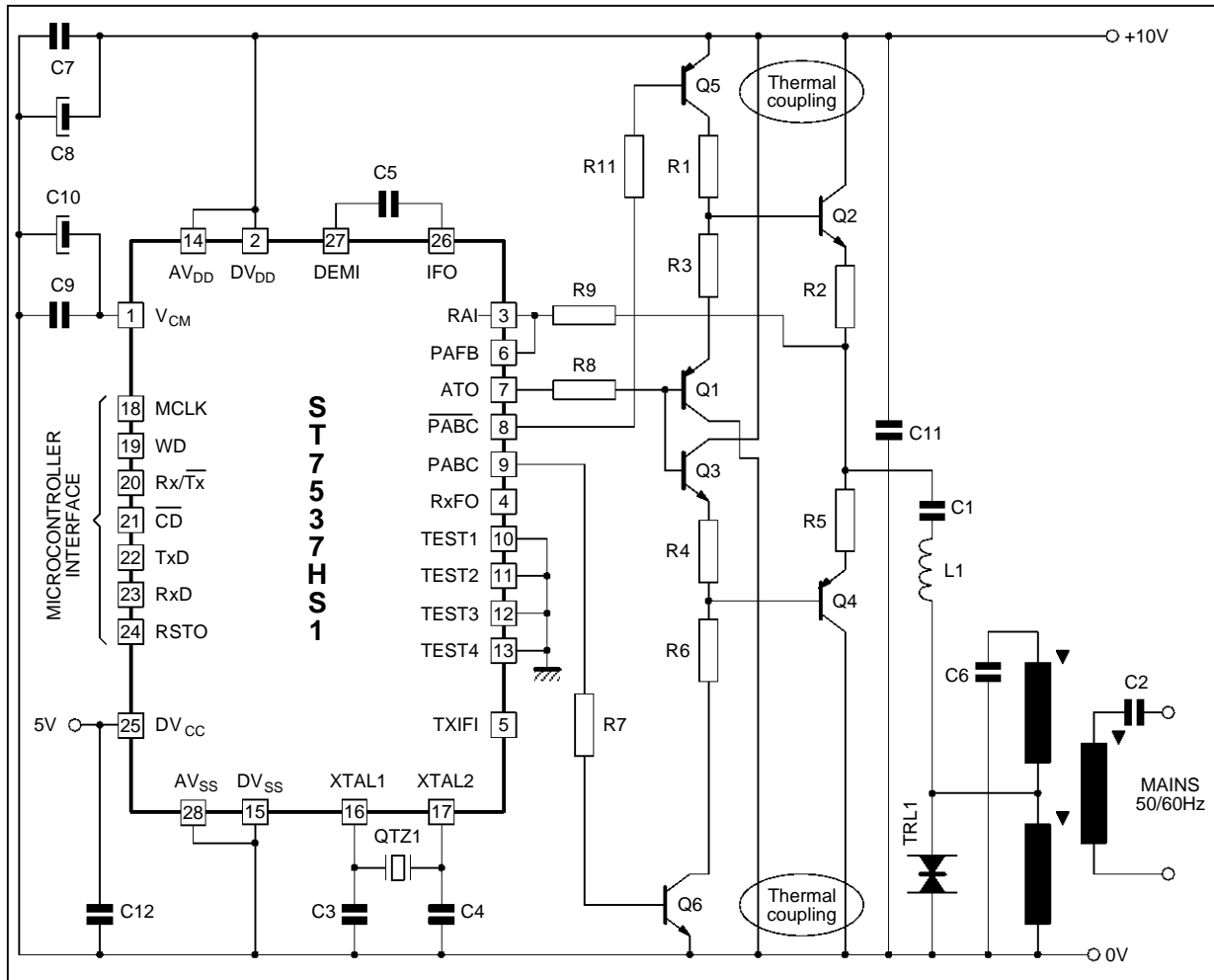

7537H-06.EPS

**PACKAGE MECHANICAL DATA**  
28 PINS - PLASTIC CHIP CARRIER

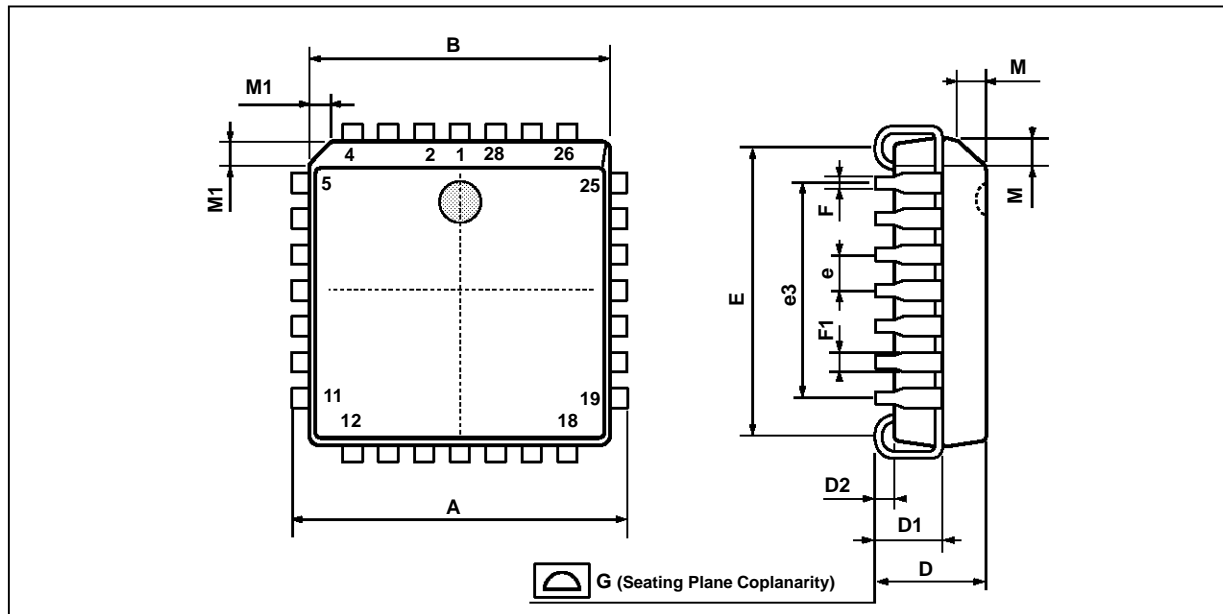

PMPLCC28.EPS

Dimensions	Millimeters			Inches		
	Min.	Typ.	Max.	Min.	Typ.	Max.
A	12.32		12.57	0.485		0.495
B	11.43		11.58	0.450		0.456
D	4.2		4.57	0.165		0.180
D1	2.29		3.04	0.090		0.120
D2	0.51			0.020		
E	9.91		10.92	0.390		0.430
e		1.27			0.050	
e3		7.62			0.300	
F		0.46			0.018	
F1		0.71			0.028	
G			0.101			0.004
M		1.24			0.049	
M1		1.143			0.045	

PLCC28.TBL

Information furnished is believed to be accurate and reliable. However, SGS-THOMSON Microelectronics assumes no responsibility for the consequences of use of such information nor for any infringement of patents or other rights of third parties which may result from its use. No licence is granted by implication or otherwise under any patent or patent rights of SGS-THOMSON Microelectronics. Specifications mentioned in this publication are subject to change without notice. This publication supersedes and replaces all information previously supplied. SGS-THOMSON Microelectronics products are not authorized for use as critical components in life support devices or systems without express written approval of SGS-THOMSON Microelectronics.

© 1995 SGS-THOMSON Microelectronics - All Rights Reserved

Purchase of I<sup>2</sup>C Components of SGS-THOMSON Microelectronics, conveys a license under the Philips I<sup>2</sup>C Patent. Rights to use these components in a I<sup>2</sup>C system, is granted provided that the system conforms to the I<sup>2</sup>C Standard Specifications as defined by Philips.

SGS-THOMSON Microelectronics GROUP OF COMPANIES

Australia - Brazil - China - France - Germany - Hong Kong - Italy - Japan - Korea - Malaysia - Malta - Morocco  
The Netherlands - Singapore - Spain - Sweden - Switzerland - Taiwan - Thailand - United Kingdom - U.S.A.