

NOT RECOMMENDED FOR NEW DESIGNS

14-Bit Multiplying Microprocessor-Compatible D/A Converter

Features

- 14-Bit Linearity (0.003% FSR)
- No Gain Adjustment Necessary
- Microprocessor-Compatible with Double Buffered Inputs
- Bipolar Application Requires No Extra Adjustments or External Resistors
- Low Linearity and Gain Temperature Coefficients
- Low Power Dissipation
- Full Four-Quadrant Multiplication
- 883B Processed Versions Available

Description

The ICL7134 combines a four-quadrant multiplying DAC using thin film resistor and CMOS circuitry with an on-chip PROM-controlled correction circuit to achieve true 14-bit linearity without laser trimming.

Microprocessor bus interfacing is eased using standard memory WRITE cycle timing and control signal use. Two input buffer registers are separately loaded with the 8 least significant bits (LS register) and the 6 most significant bits (MS register). Their contents are then transferred to the 14-bit DAC register, which controls the current switches. The DAC register can also be loaded directly from the data inputs, in which case the MS and LS registers are transparent.

The ICL7134 is available in two versions. The ICL7134U is programmed for unipolar operation while the ICL7134B is programmed for bipolar applications. The V_{REF} input to the most significant bit of the DAC is separated from the reference input to the remainder of the ladder. For unipolar use, the two reference inputs are tied together, while for bipolar operation, the polarity of the MSB reference is reversed, giving the DAC a true 2's complement input transfer function. Two resistors which facilitate the reference inversion are included on the chip, so only an external op-amp is needed. The PROM is coded to correct for errors in these resistors as well as the inversion of the MSB.

Ordering Information

NON-LINEARITY AT 25°C	TEMPERATURE RANGE (°C)			PACKAGE
	0 to 70	-25 to 85	-55 to 125	
BIPOLAR VERSIONS				
0.01% (12-bit)	ICL7134BJCJI	ICL7134BJIJI	ICL7134BJMJI	28 Ld CERDIP
0.006% (13-bit)	ICL7134BKCJI	ICL7134BKIJI	ICL7134BKMJI	28 Ld CERDIP
0.003% (14-bit)	ICL7134BLCJI	ICL7134BLIJI	ICL7134BLMJI	28 Ld CERDIP
UNIPLAR VERSIONS				
0.01% (12-bit)	ICL7134UJCJI	ICL7134UJIJI	ICL7134UJMJI	28 Ld CERDIP
0.006% (13-bit)	ICL7134UKCJI	ICL7134UKIJI	ICL7134UKMJI	28 Ld CERDIP
0.003% (14-bit)	ICL7134ULCJI	ICL7134ULIJI	ICL7134ULMJI	28 Ld CERDIP

ICL7134

Absolute Maximum Ratings (Note 1)

Supply Voltage (V+ to DGND)	-0.3V to 7.5V
V _{RFL} , V _{RFM} , R _{INV} , R _{FB} to DGND	±15V
I _{OUT} , AGND _F , AGND _S	-0.1V to V+
Current in AGND _S , AGND _F	±25mA
An, Dn, WR, CS, PROG	-0.3V to V+ +0.3V

Thermal Information

Storage Temperature Range	-65°C to 150°C
Power Dissipation (Note 2)	500mW
Derate Linearly Above 70°C @ 10mW/°C	
Lead Temperature (Soldering, 10s)	300°C

Operating Conditions

Temperature Range

ICL7134XXC	0°C to 70°C
ICL7134XXI	-25°C to 85°C
ICL7134XXM	-55°C to 125°C

CAUTION: Stresses above those listed in "Absolute Maximum Ratings" may cause permanent damage to the device. This is a stress only rating and operation of the device at these or any other conditions above those indicated in the operational sections of this specification is not implied.

NOTES:

1. All voltages with respect to DGND.
2. Assumes all leads soldered or welded to printed circuit board.

Electrical Specification

V₊ = +5V, V_{REF} = +10V, T_A = 25°C, AGND = DGND, I_{OUT} at Ground Potential, Unless Otherwise Specified.

PARAMETER	TEST CONDITIONS	MIN	TYP	MAX	UNITS	
DC ACCURACY						
Resolution		14	-	-	Bits	
Non-Linearity	(Notes 3 and 4) Figure 2	J	-	-	±0.012	%FSR
		K	-	-	±0.006	%FSR
		L	-	-	±0.003	%FSR
Non-Linearity Temperature Coefficient	Operating Temperature Range (Note 5)	-	±1	±2	ppm/°C	
Monotonicity	(Note 5)	J	12	-	-	Bits
		K	13	-	-	Bits
		L	14	-	-	Bits
Gain Error	(Notes 3 and 4) Figure 1	J	-	-	±0.024	%FSR
		K	-	-	±0.012	%FSR
		L	-	-	±0.006	%FSR
Gain Error Temperature Coefficient	(Note 5)	-	±2	±8	ppm/°C	
Output Leakage Current (I _{OUT} Terminal)	T _A = 25°C	-	-	±10	nA	
	Operating Temperature Range	-	±60	-	nA	
Long Term Stability of I _{OUT}	1000 Hours, 125°C, (Note 5)	-	±10	-	ppm/month	
AC ACCURACY						
Power Supply Rejection	ΔV ₊ = ±10%, Figure 2, T _A = 25°C	-	±10	±100	ppm/V	
	Operating Temperature Range	-	-	±150	ppm/V	
Feedthrough Error	V _{REF} = 20V _{P-P} , 2kHz	U	-	250	μV _{P-P}	
	Sinewave, Figure 3	B	-	500	μV _{P-P}	
Output Current Setting Time	T ₀ 1/2 LSB, Figure 4	-	1	-	μs	
Output Noise	Equivalent to Johnson Noise of 7kΩ Resistor, Typical					

ICL7134

Electrical Specification $V_+ = +5V$, $V_{REF} = +10V$, $T_A = 25^\circ C$, $AGND = DGND$, I_{OUT} at Ground Potential, Unless Otherwise Specified. **(Continued)**

PARAMETER	TEST CONDITIONS	MIN	TYP	MAX	UNITS
REFERENCE INPUT					
Input Resistance	$V_{RFL} = V_{RFM}$, I_{OUT} at Ground	4	7	10	k Ω
ANALOG OUTPUT					
Output Capacitance (I_{OUT} Terminal)	DAC Register Outputs All LOW	-	160	-	pF
	DAC Register Outputs All HIGH	-	235	-	pF
DIGITAL INPUTS					
Low State Threshold	Operating Temperature Range	-	-	0.8	V
High State Threshold		2.4	-	-	V
Input Current	Inputs between DGND to V_+	-	-	± 1	μA
Input Capacitance	(Note 5)	-	15	-	pF
POWER SUPPLY					
Supply Voltage Range	Functional Operation, (Note 6)	3.5	-	6.0	V
Supply Current	Excluding Ladder Network (Note 7)	-	1.0	2.5	mA

NOTES:

3. Full-Scale Range (FSR) is 10V for unipolar mode, 20V ($\pm 10V$) for bipolar mode.
4. Using internal feedback and reference inverting resistors.
5. Guaranteed by design, not production tested.
6. Gain error tested to 0.040% FSR, Specifications are not guaranteed.
7. D0 - D13 connected to 2.4V.

Switching Specifications $V_+ = 5V$, $T_A = 25^\circ C$, See Timing Diagram

PARAMETER	SYMBOL	TEST CONDITIONS	MIN	TYP	MAX	UNITS
Address- \overline{WRITE} Set-Up Time	t_{AWs}		150	-	-	ns
Address- \overline{WRITE} Hold Time	t_{AWh}	Note 5	0	-	-	ns
$\overline{CHIP\ SELECT}$ - \overline{WRITE} Set-Up Time	t_{CWs}	Note 5	0	-	-	ns
$\overline{CHIP\ SELECT}$ - \overline{WRITE} Hold Time	t_{CWh}	Note 5	0	-	-	ns
\overline{WRITE} Pulse Width Low	t_{WR}		200	-	-	ns
Data- \overline{WRITE} Set-Up Time	t_{DWs}		200	-	-	ns
Data- \overline{WRITE} Hold Time	t_{DWh}	Note 5	0	-	-	ns

Test Circuits

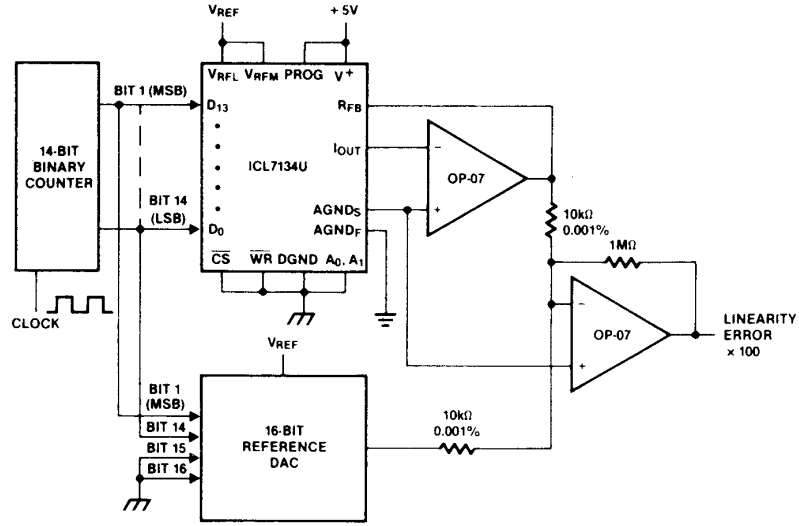

FIGURE 1. NON-LINEARITY TEST CIRCUIT

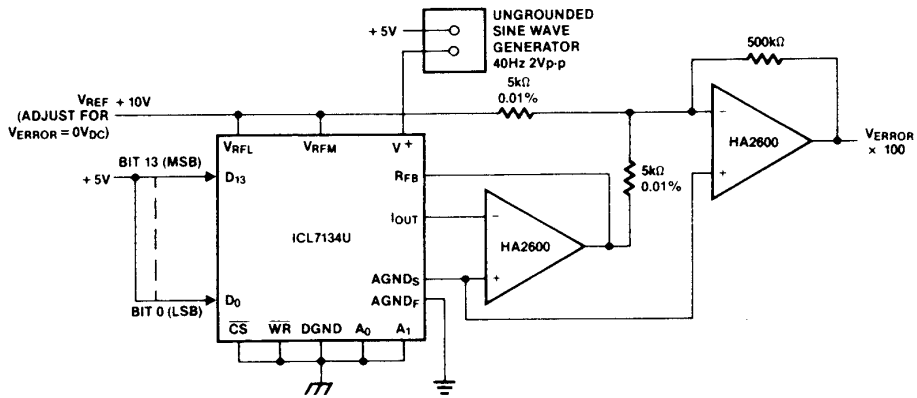

FIGURE 2. POWER SUPPLY REJECTION TEST CIRCUIT

Test Circuits (Continued)

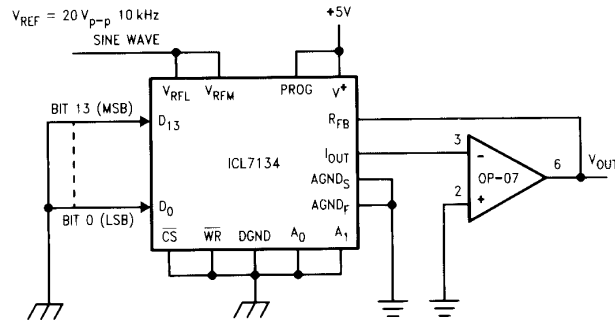

FIGURE 3. FEEDTHROUGH ERROR TEST CIRCUIT

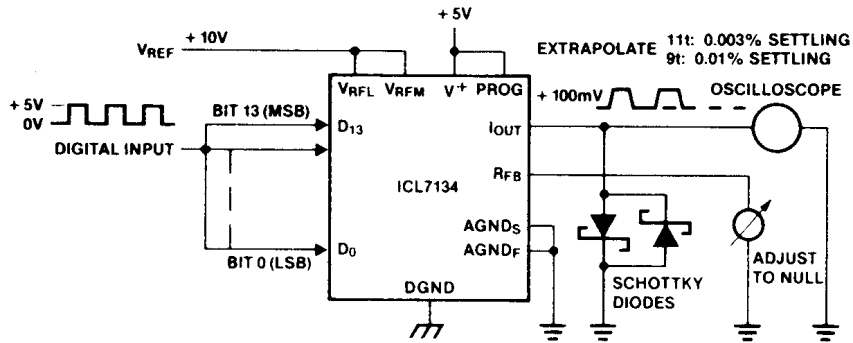

FIGURE 4. OUTPUT CURRENT SETTLING TIME TEST CIRCUIT

Timing Diagrams

Using 14 Bit Transparent Addressing

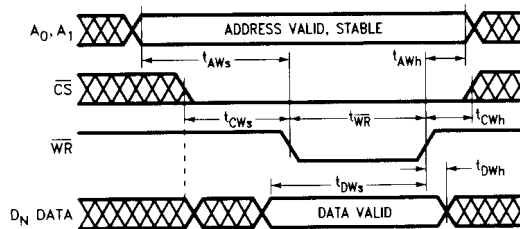

FIGURE 5A. USING 14-BIT TRANSPARENT ADDRESSING

Timing Diagrams

Using Full Buffer 8 Bit Addressing Capability

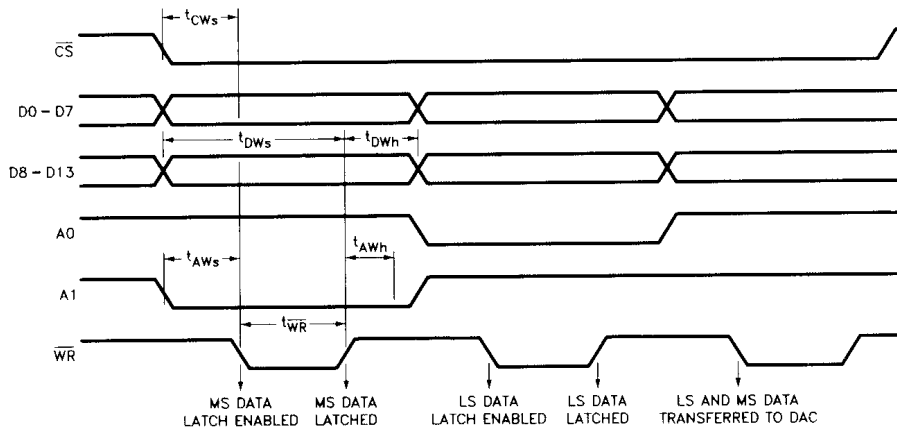

FIGURE 5B. USING FULL BUFFER 8-BIT ADDRESSING CAPABILITY

Definition of Terms

Nonlinearity - Error contributed by deviation of the DAC transfer function from a straight line through the end points of the actual plot of transfer function. Normally expressed as a percentage of full scale range or in (sub)multiples of 1 LSB.

Resolution - It is addressing the smallest distinct analog output change that a D/A converter can produce. It is commonly expressed as the number of converter bits. A converter with resolution of n bits can resolve output changes of 2^{-n} of the full-scale range, e.g. $2^{-n} V_{REF}$ for a unipolar conversion. Resolution by no means implies linearity.

Settling Time - Time required for the output of a DAC to settle to within specified error band around its final value (e.g. 1/2 LSB) for a given digital input change, i.e. all digital inputs LOW to HIGH and HIGH to LOW.

Gain Error - The difference between actual and ideal analog output values at full-scale range, i.e., all digital inputs at HIGH state. It is expressed as a percentage of full-scale range or in (sub)multiples of 1 LSB.

Feedthrough Error - Error caused by capacitive coupling from V_{REF} to I_{OUT} with all digital inputs LOW.

Output Capacitance - Capacitance from I_{OUT} terminal to ground.

Output Leakage Current - Current which appears on I_{OUT} terminal when all DAC register outputs are LOW.

Detailed Description

The ICL7134 consists of 14-bit primary DAC, two PROM controlled correction DACs, input buffer registers, and microprocessor interface logic (See Functional Block Diagram). The 14-bit primary DAC is an R-2R thin film resistor ladder with N-channel MOS SPDT current steering switches. Precise balancing of the switch resistances, and all other resistances in the ladder, results in excellent temperature stability.

True 14-bit linearity is achieved by programming a floating polysilicon gate PROM array which controls two correction DAC circuits. A 6-bit gain correction DAC, or G-DAC, diverts up to 2% of the feedback resistor's current to Analog GND and reduces the gain error to less than 1 LSB, or 0.006%. The 5 most

significant outputs of the DAC register address a 31-word PROM array that controls a 12-bit linearity correction DAC, or C-DAC. For every combination of the primary DAC's 5 most significant bits, a different C-DAC code is selected. This allows correction of superposition errors, caused by bit interaction on the primary resistor ladder's current output bus and by voltage non-linearity in the feedback resistor. Superposition errors cannot be corrected by any method which corrects individual bits only, such as laser trimming. Since the PROM programming occurs in packaged form, it corrects for resistor shifts caused by the thermal stresses of packaging. These packaging shifts limit the accuracy that can be achieved using wafer level correction methods such as laser trimming, which has also been found to degrade the time stability of thin film resistors at the 14-bit level.

Analog Section

The ICL7134 inherently provides both unipolar and bipolar operation. The bipolar application circuit (Figure 6) requires one additional op-amp but no external resistors. The two on-chip resistors, R_{INV1} and R_{INV2} , together with the op-amp, form a voltage inverter which drives the MSG reference terminal, V_{RFM} , to $-V_{REF}$, where V_{REF} is the voltage applied at the less significant bits' reference terminal, V_{RFL} . Notice the values of $1.95R$ and $2R$ for the R_{INV1} and R_{INV2} . The V_{RFM} absolute value is about 2.5% higher than the V_{RFL} . This is necessary so that the gain error can be corrected. This reverses the weight of the MSG, and gives the DAC a 2's complement transfer function. The op-amp and reference connection to V_{RFM} and V_{RFL} can be reversed, without affecting linearity, but a small gain error will be introduced. For unipolar operation the V_{RFM} and V_{RFL} terminals are both tied to V_{REF} , and the R_{INV} pin is left unconnected.

Since the PROM correction codes required are different for bipolar and unipolar operation, the ICL7134 is available in two different versions; the ICL7134U, which is corrected for unipolar operation, and the ICL7134B, which is programmed for bipolar application. The feedback resistance is also different in the two versions, and is switched under PROM control from 'R' in the unipolar device to '2R' in the bipolar part. These feedback resistors have a dummy (always ON) switch in series to compensate for the effect of the ladder switches. This greatly improves the gain temperature coefficient and the power supply rejection of the device.

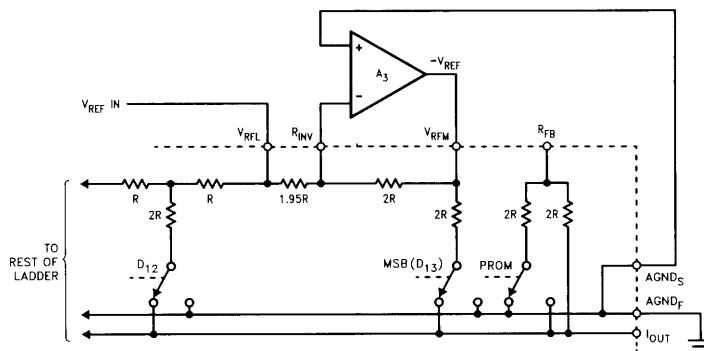

FIGURE 6. BIPOLAR OPERATION WITH INVERTED V_{REF} TO MSB

Digital Section

Two levels of input buffer registers allow loading of data from an 8-bit or 16-bit data bus. The A_0 and A_1 pins select one of four operations: 1) load the LS-buffer register with the data at inputs D_0 to D_7 ; 2) load the MS-buffer register with the data at inputs D_8 to D_{13} ; 3) load the DAC register with the contents of the MS and LS-buffer registers and 4) load the DAC register directly from the data input pins (See Table 1). The \overline{CS} and \overline{WR} pins must be low to allow data transfers to occur. When direct loading is selected (\overline{CS} , \overline{WR} , A_0 and A_1 low) the registers are transparent, and the data input pins control the DAC output directly. The other modes of operation allow double buffered loading of the DAC from an 8-bit bus.

These input data pins are also used to program the PROM under control of the PROG pin. This is done in manufacturing, and for normal operation the PROG pin should be tied to V_+ (+5V).

TABLE 1. DATA LOADING CONTROLS

CONTROL I/P				ICL7134 OPERATION
A_0	A_1	\overline{CS}	\overline{WR}	
X	X	X	1	No Operation, Device Not Selected.
X	X	1	X	
0	0	0	0	Load All Registers from Data Bus.
0	1	0	0	Load LS Register from Data Bus.
1	0	0	0	Load MS Register from Data Bus.
1	1	0	0	Load DAC Register from MS and LS Register.

NOTE: Data is latched on LO-HI transition of either \overline{WR} or \overline{CS} .

Applications

GENERAL RECOMMENDATIONS

Grounding

Careful consideration must be given to grounding in any 14-bit accuracy system. The current into the analog ground point inside the chip varies significantly with the input code value, and the inevitable resistances between this point and any external connection pint can lead to significant voltage drop errors. For this reason, two separate leads are brought out from this point on the IC, the $AGND_F$ and $AGND_S$ pins. The varying current should be absorbed through the $AGND_F$ pin, and the $AGND_S$ pin will then accurately reflect the voltage on the internal current summing point, as shown in Figure 7. Thus output signals should be referenced to the sense pin $AGND_S$, as shown in the various application circuits.

Operational Amplifier Selection

To maintain static accuracy, the I_{OUT} potential must be exactly equal to the $AGND_S$ potential. Thus output amplifier selection is critical, in particular low input bias current (less than 2nA), low offset voltage (less than 25 μ V) are advisable if the highest accuracy is needed. Maintaining a low input offset over a 0V to 10V range also requires that the output amplifier has a high open loop gain ($A_{VOL} > 400k$ for

effective input offset less than 25 μ V).

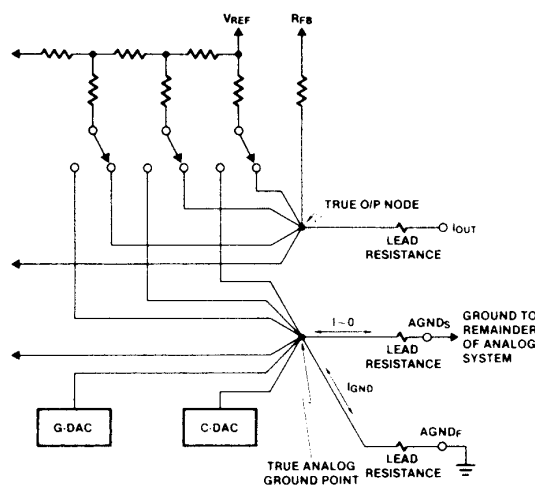

FIGURE 7. GROUND CONNECTIONS

The reference inverting amplifier used in the bipolar mode circuit must also be selected carefully. If 14-bit accuracy is desired without adjustment, low input bias current (less than 1nA), low offset voltage (less than 50 μ V), and high gain (greater than 400k) are recommended. If a fixed reference voltage is used, the gain requirement can be relaxed. For highest accuracy (better than 13-bits), and additional op-amp may be needed to correct for IR drop on the Analog GROUND line (op-amp A_2 in Figure 9). This op-amp should be selected for low bias current (less than 2nA) and low offset voltage (less than 50 μ V).

The op-amp requirements can be readily met by use of an ICL7650 chopper stabilized device. For faster setting time, an HA26XX can be used with an ICL7650 providing automatic offset null (see A053 applications note for details)

The output amplifier's non-inverting input should be tied directly to $AGND_S$. A bias current compensation resistor is of limited use since the output impedance at the summing node depends on the code being converted in an unpredictable way. If gain adjustment is required, low tempco (approximately 50ppm/ $^{\circ}$ C) resistors or trim-pots should be selected.

Power Supplies

The V_+ (pin 25) power supply should have a low noise level, and no transients exceeding 7 volts. Note that the absolute maximum for digital input voltage is $V_+ + 0.3V$, therefore V_+ must be applied before digital inputs are allowed to go high. Unused digital inputs must be connected to GND or V_+ for proper operation.

Unipolar Binary Operation (ICL7134U)

The circuit configuration for unipolar mode operation (ICL7134U) is shown in Figure 8. With positive and negative V_{REF} values the circuit is capable of two-quadrant multiplication. The "digital input code/analog output value" table for unipolar mode is given in Table 2. The Schottky diode (HP5082-2811 or equivalent) protects I_{OUT} from

negative excursions which could damage the device, and is only necessary with certain high speed amplifiers. For applications where the output reference ground point is established somewhere other than at the DAC, the circuit of Figure 9 can be used. Here, op-amp A₂ removes the slight error due to IR voltage drop between the internal Analog Ground node and the external ground connection. For 13-bit or lower accuracy, omit A₂ and connect AGND_F and AGND_S directly to ground through as low a resistance as possible.

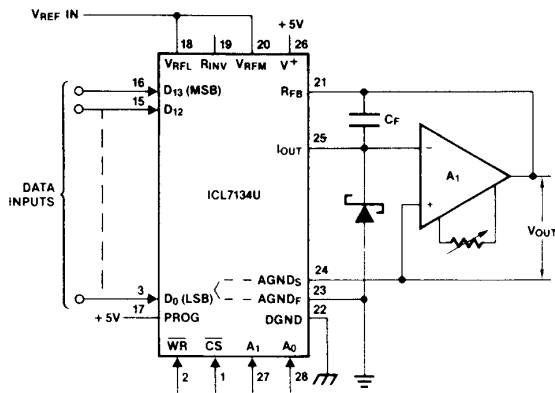

FIGURE 8. UNIPOLAR BINARY, TWO-QUADRANT MULTIPLYING CIRCUIT

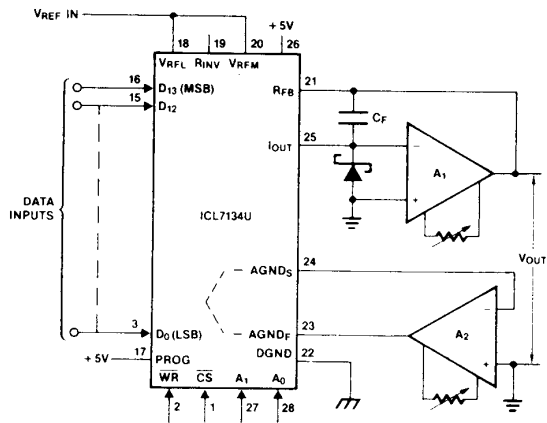

FIGURE 9. UNIPOLAR BINARY OPERATION WITH FORCED GROUND

TABLE 2. CODE TABLE - UNIPOLAR BINARY OPERATION

DIGITAL INPUT	ANALOG OUTPUT
1 1 1 1 1 1 1 1 1 1 1 1 1 1 1 1	$-V_{REF} (1 - 1/2^{14})$
1 0 0 0 0 0 0 0 0 0 0 0 0 0 1	$-V_{REF} (1/2 + 1/2^{14})$
1 0 0 0 0 0 0 0 0 0 0 0 0 0 0	$-V_{REF}/2$
0 1 1 1 1 1 1 1 1 1 1 1 1 1 1	$-V_{REF} (1/2 - 1/2^{14})$
0 0 0 0 0 0 0 0 0 0 0 0 0 0 1	$-V_{REF} (1/2^{14})$
0 0 0 0 0 0 0 0 0 0 0 0 0 0 0	0

Zero Offset Adjustment

1. Connect all data inputs and \overline{WR} , \overline{CS} , A₀ and A₁ to DGND.
2. Adjust offset zero-adjust trim-pot of the operational amplifier A₂, if used, for a maximum of $0V \pm 50\mu V$ at AGND_S.
3. Adjust the offset zero-adjust trim-pot of the output op-amp, A₁, for a maximum of $0V \pm 50\mu V$ at V_{OUT}.

Gain Adjustment (Optional)

1. Connect all data inputs to V+, connect \overline{WR} , \overline{CS} , A₀ and A₁ to DGND.
2. Monitor V_{OUT} for a $-V_{REF} (1 - 1/2^{14})$ reading.
3. To decrease V_{OUT}, connect a series resistor of 5Ω or less between the reference voltage and the V_{RFM} and V_{RFL} terminals (pins 20 and 18).
4. To increase V_{OUT}, connect a series resistor of 5Ω or less between A₁ output and the R_{FB} terminal (pin 21).

Bipolar (2's Complement) Operation (ICL7134B)

The circuit configuration for bipolar mode operation (ICL7134B) is shown in Figure 10. Using 2's complement digital input codes and positive and negative reference voltage values, four-quadrant multiplication is obtained. The "digital input code/analog output value" table for bipolar mode is given in Table 3. Amplifier A₃, together with internal resistors R_{INV1} and R_{INV2}, forms a simple voltage inverter circuit. The MSB ladder leg sees a reference input of approximately -V_{REF}, so the MSB's weight is reversed from the polarity of the other bits. In addition, the ICL7134B's feedback resistance is switched to 2R under PROM control, so that the bipolar output range is +V_{REF} to -V_{REF} (1 - 1/2¹³). Again, the grounding arrangement of Figure 9 can be used if necessary.

TABLE 3. CODE TABLE - BIPOLAR (2'S COMPLEMENT) OPERATION

DIGITAL INPUT	ANALOG OUTPUT
0 1 1 1 1 1 1 1 1 1 1 1 1 1 1	$-V_{REF} (1 - 1/2^{13})$
0 0 0 0 0 0 0 0 0 0 0 0 0 0 1	$-V_{REF} (1/2^{13})$
0 0 0 0 0 0 0 0 0 0 0 0 0 0 0	0
1 1 1 1 1 1 1 1 1 1 1 1 1 1 1	$V_{REF} (1/2^{13})$
1 0 0 0 0 0 0 0 0 0 0 0 0 0 1	$V_{REF} (1 - 1/2^{13})$
1 0 0 0 0 0 0 0 0 0 0 0 0 0 0	V_{REF}

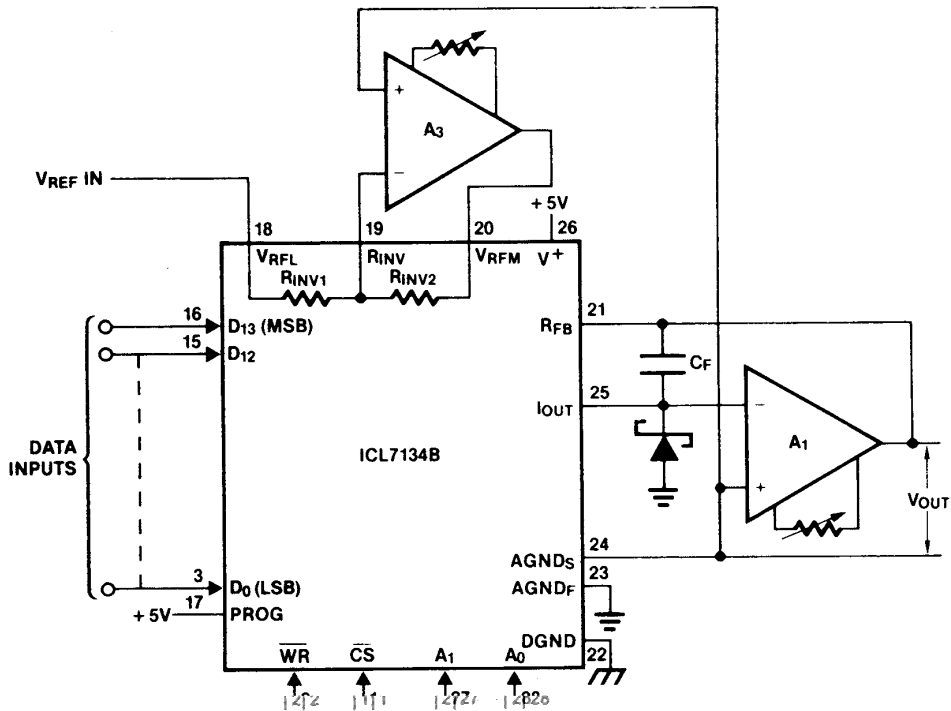

FIGURE 10. BIPOLAR (2'S COMPLEMENT), FOUR-QUADRANT MULTIPLYING CIRCUIT

Offset Adjustment

1. Connect all data inputs and \overline{WR} , \overline{CS} , A_0 and A_1 to DGND.
2. Adjust the offset zero-adjust trim-pot of the operational amplifier A_2 , if used, for a maximum of $0V \pm 50\mu V$ at $AGND_S$.
3. Set data to 000000...00. Adjust the offset zero-adjust trim-pot of any output op-amp A_1 , for a maximum of $0V \pm 50\mu V$ at V_{OUT} .
4. Connect D_{13} (MSB) data input to $V+$.
5. Adjust the offset zero-adjust trim-pot of op-amp A_3 for a maximum of $0V \pm 50\mu V$ at the R_{INV} terminal (pin 19).

Gain Adjustment (Optional)

1. Connect \overline{WR} , \overline{CS} , A_0 and A_1 to DGND.
2. Connect $D_0, D_1 \dots D_{12}$ to $V+$, D_{13} (MSB) to DGND.
3. Monitor V_{OUT} for a $-V_{REF} (1 - 1/2^{13})$ reading.
4. To increase V_{OUT} , connect a series resistor of 10Ω or less between the A_1 output and the R_{FB} terminal (pin 21).
5. To decrease V_{OUT} , connect a series resistor of 5Ω or less between the reference voltage and the V_{RFL} terminal (pin 18).

Processor Interfacing

The ease of interfacing to a processor can be seen from Figure 11, which shows the ICL7134 connected to an 8035 or any other processor such as an 8049. The data bus feeds into both register inputs; three port lines, in combination with the \overline{WR} line, control the byte-wide loading into these registers and then the DAC register. A complete DAC set-up requires 4 write instructions to the port, to set up the address and \overline{CS} lines, and 3 external data transfers, one a dummy for the final transfer to the DAC register.

A similar arrangement can be used with an 8080A, 8228, and 8224 chip set. Figure 12 shows the circuit, which can be arranged as a memory-mapped interface (using \overline{MEMW}) or as an I/O-mapped interface (using I/O \overline{WRITE}). See A020 and R005 for discussions of the relative merits of memory-mapped versus I/O-mapped interfacing, as well as some other ideas on interfacing with 8080 processors. The 8085 processor has a very similar interface, except that the control lines available are slightly different, as shown in Figure 13. The decoding of the IO/M line, which controls memory-mapped or I/O-mapped operation, is arbitrary, and can be omitted if not necessary. Neither the MC680X nor R650X processor families offer specific I/O operations. Figure 14 shows a suitable interface to either of these systems, using a direct connection. Several other decoding options can be used, depending on the other control signals generated in the system. Note that the R650X family does not require VMA to be decoded with the address lines.

ICL7134

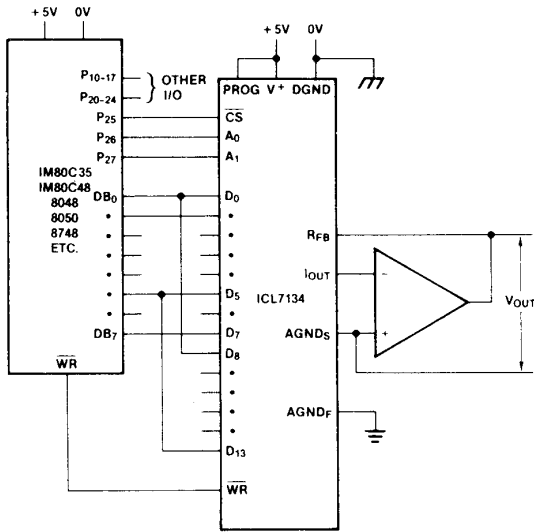

FIGURE 11. ICL7134 INTERFACE TO 8048 SYSTEM

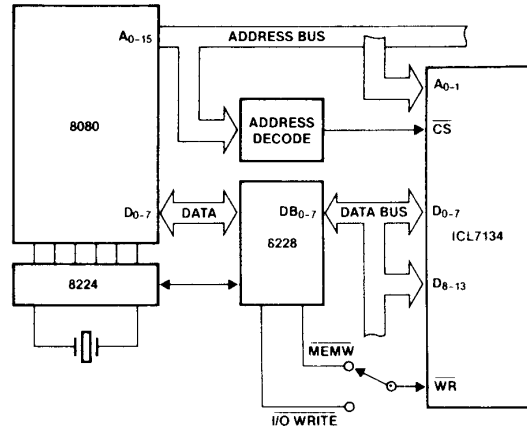

FIGURE 12. INTERFACE TO 8080 SYSTEM

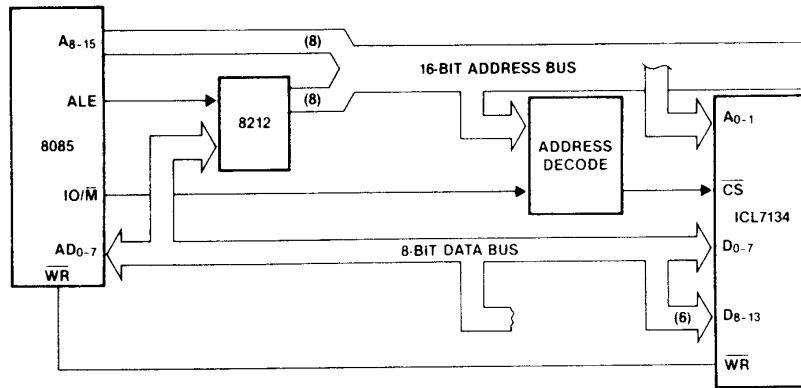

FIGURE 13. 8085 SYSTEM INTERFACE

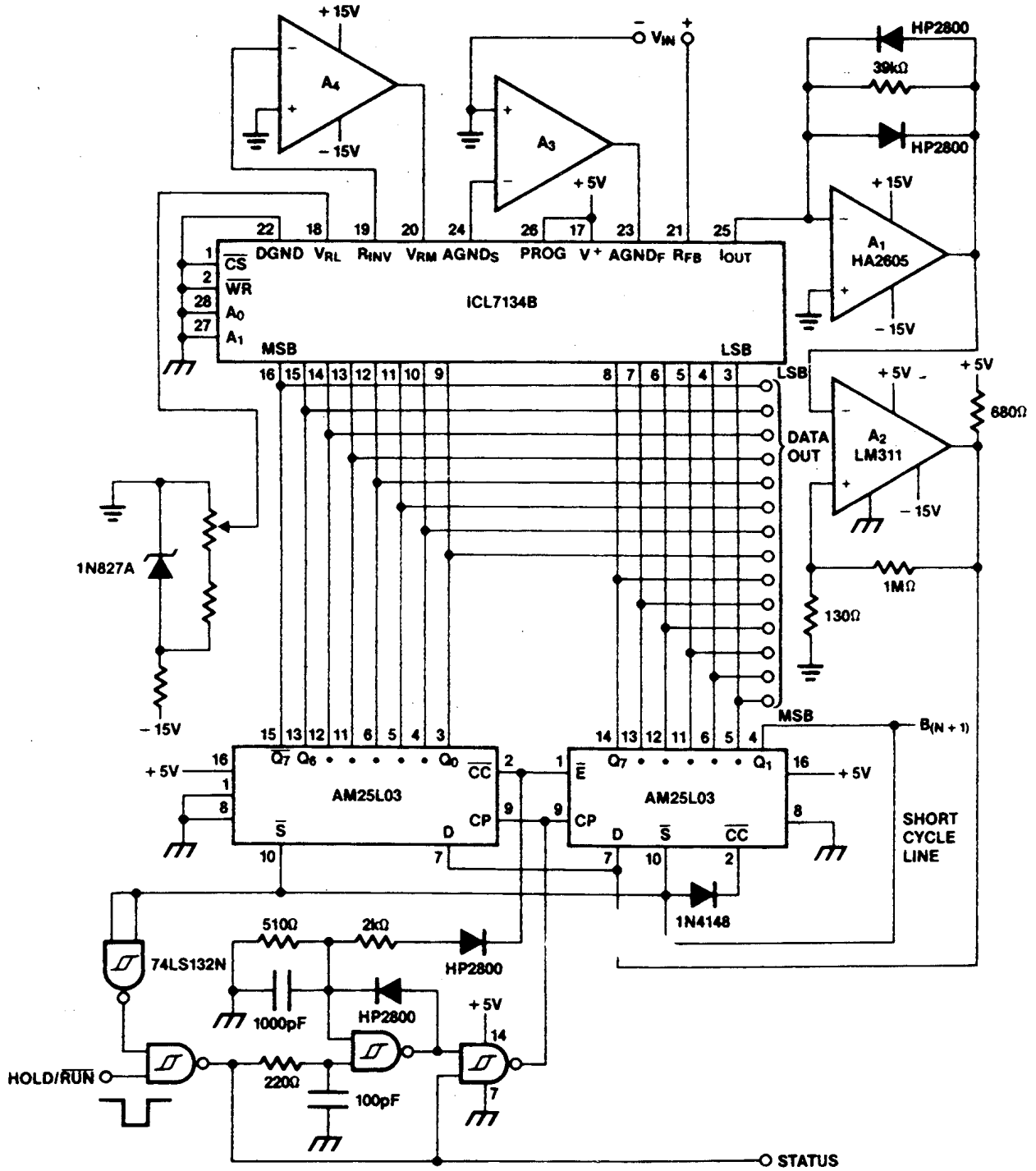

FIGURE 17. SUCCESSIVE APPROXIMATION A/D CONVERTER

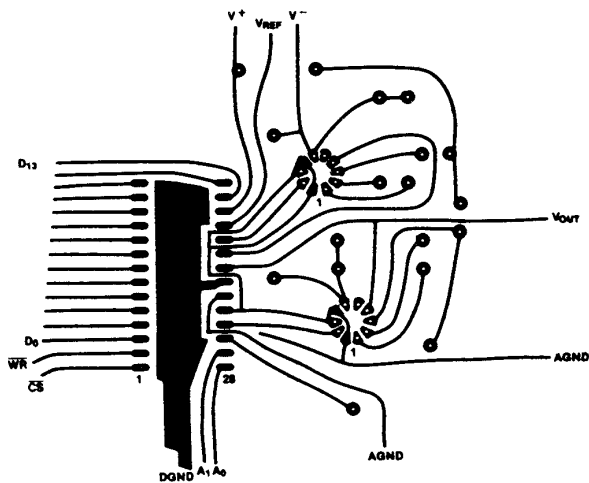

FIGURE 18A. PRINTED CIRCUIT SIDE OF CARD (SINGLE SIDED BOARD)

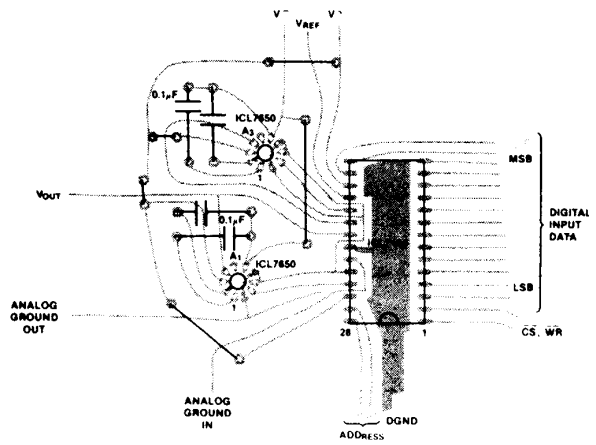

FIGURE 18B. TOP SIDE WITH COMPONENT PLACEMENT

FIGURE 18. PRINTED CIRCUIT BOARD LAYOUT (BIPOLAR CIRCUIT, SEE FIGURE 10)

PC Board Layout

Great care should be taken in the board layout to minimize ground loop and similar "hidden resistor" problems, as well as to minimize digital signal feedthrough. A suitable layout for the immediate vicinity of the ICL7134 is shown in Figure 18, and may be used as a guide.

Application Notes

Some applications bulletins that may be found useful are listed here:

- A002** "Principles of Data Acquisition and Conversion"
- A018** "Do's and Don'ts of Applying A/D Converters", by Peter Bradshaw and Skip Osgood.
- A020** "A Cookbook Approach to High Speed Data Acquisition and Microprocessor Interfacing", by Ed Sliger.
- A042** "Interpretation of Data Converters Accuracy Specifications"
- R005** "Interfacing Data Converters & Microprocessor", by Peter Bradshaw et al., Electronics, Dec 9, 1976.

Most of these are available in the Intersil Data Acquisition Handbook, together with other material.

This datasheet has been downloaded from:

www.DatasheetCatalog.com

Datasheets for electronic components.



LittleDiode supplies new, hard to find or obsolete electronic components and semiconductors all over the world.

With over two million different components listed you are sure to find the part you need.

Feel free to visit us today at our online store:

LittleDiode.com

Looking forward to providing you with the best possible service.