

SWITCH MODE POWER SUPPLY PRIMARY CIRCUIT

- POSITIVE AND NEGATIVE OUTPUT CURRENT UP TO 1.2A AND - 1.7A
- A TWO LEVEL COLLECTOR CURRENT LIMITATION
- COMPLETE TURN OFF AFTER LONG DURATION OVERLOADS
- UNDER AND OVER VOLTAGE LOCK-OUT
- SOFT START BY PROGRESSIVE CURRENT LIMITATION
- DOUBLE PULSE SUPPRESSION
- BURST MODE OPERATION UNDER STANDBY CONDITIONS

DESCRIPTION

In a master slave architecture, the TEA2164 control IC achieves the slave function. Primarily designed for TV receivers and monitors applications, this circuit provides an easy synchronization and smart solution for low power stand by operation.

Located at the primary side the TEA2164 Control IC ensures :

- the power supply start-up
- the power supply control under stand-by conditions
- the process of the regulation signals sent by the master circuit located at the secondary side
- directbase drive of the bipolar switching transistor
- the protection of the transistor and the power supply under abnormal conditions.

For more details, refer to application note AN409.

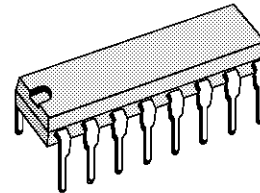

POWERDIP16
(Plastic Package)

ORDER CODE : TEA2164

PIN CONNECTIONS

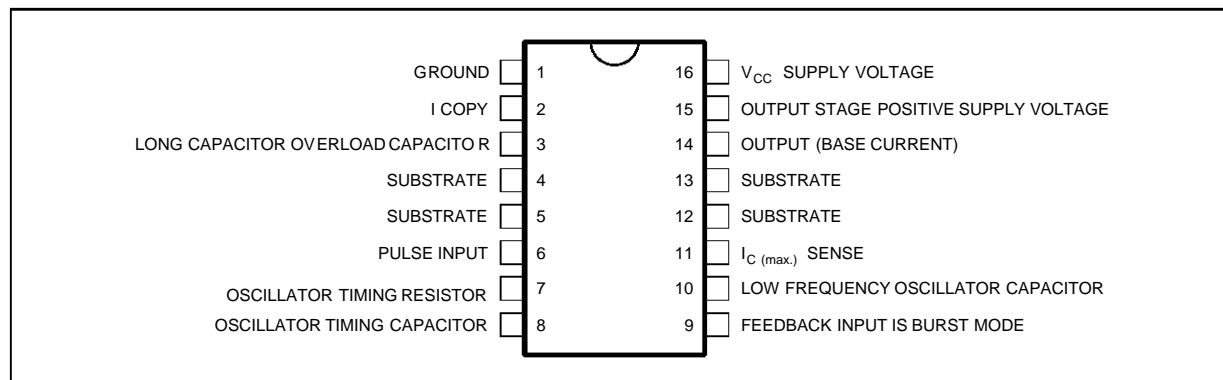

2164-01.EPS

BLOCK DIAGRAM

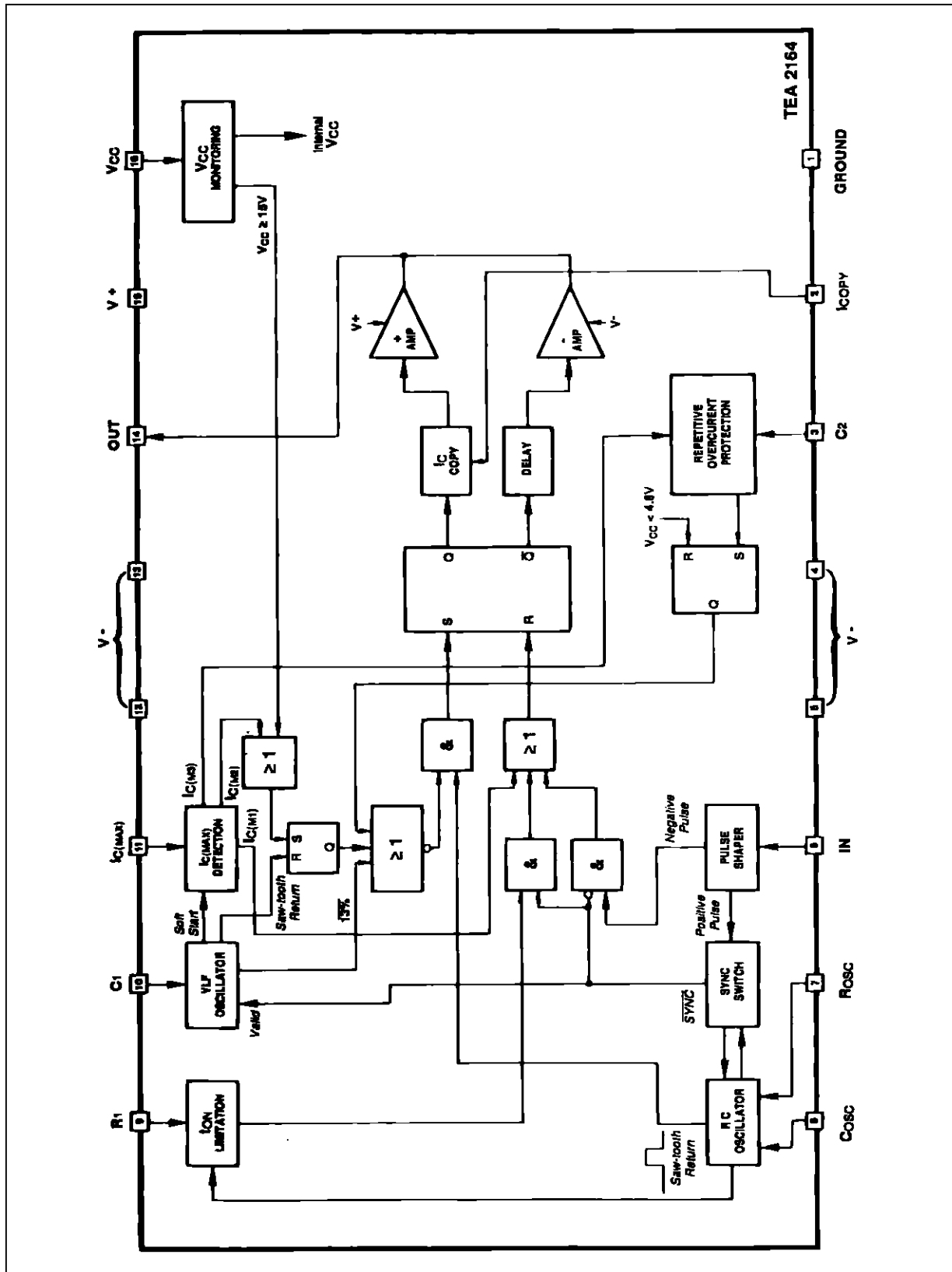

2164-02.EPS

Figure 1 : Simplified Application Diagram

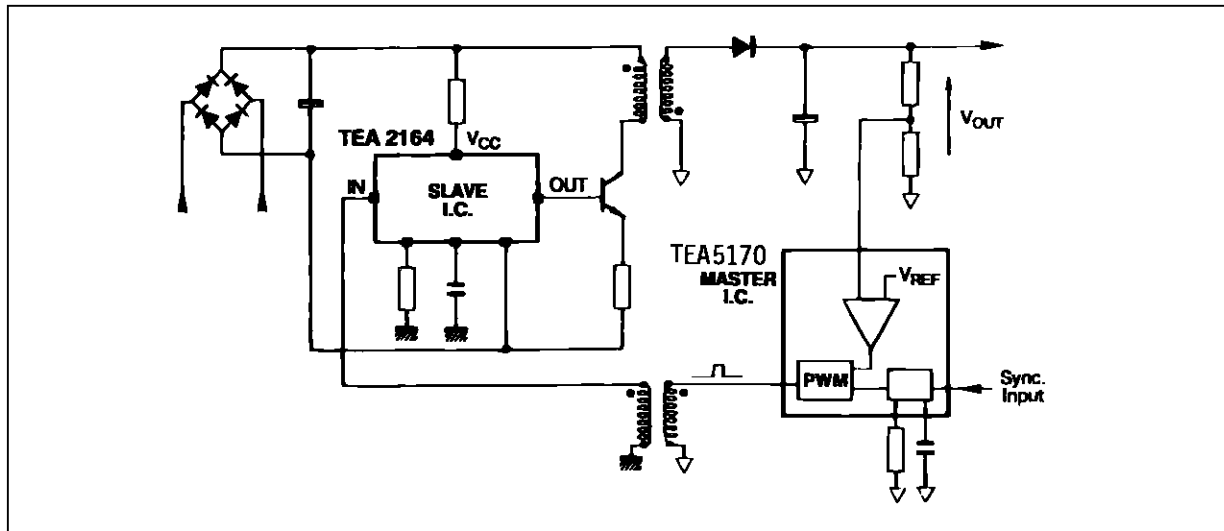

2164-03.EPS

ABSOLUTE MAXIMUM RATINGS

Symbol	Parameter	Value	Unit
V _{CC}	Positive Power Supply V16-V1	18	V
V+	Positive Power Supply of the Output Stage V15-V1	18	V
V-	Negative Power Supply V4, 5, 12, 13-V1	- 5	V
V _{CC} - V- V+ - V-	Total Power Supply V16-V4, 5, 12, 13 or V15-V4, 5, 12, 13	20	V
I _{out+}	Positive Output Current	1.5	A
I _{out-}	Negative Output Current	2	A
T _j	Operating Junction Temperature	150	°C
T _{stag}	Storage Temperature Range	- 40, + 150	°C

2164-01.TBL

THERMAL DATA

Symbol	Parameter	Value	Unit
R _{th(j-c)}	Junction Case Thermal Resistance	11	°C/W

2164-02.TBL

MAXIMUM POWER DISSIPATION

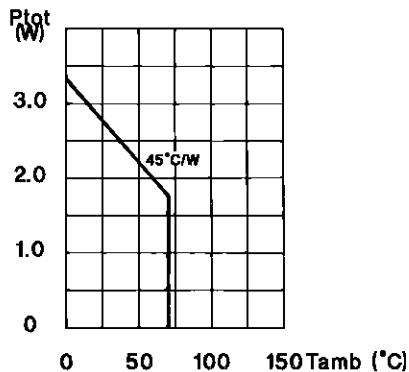

2164-04.EPS

RECOMMENDED OPERATING CONDITIONS

Symbol	Parameter	Min.	Typ.	Max.	Unit
V_{CC}	Positive Power Supply		10	14	V
$ V_{-} $	Negative Power Supply (absolute value) (note 1)	0		5	V
$V_{CC} - V_{-}$	Total Power Supply			18	V
I_{out+}	Positive Output Current			1.2	A
I_{out-}	Negative Output Current			1.7	A
F _{sw}	Switching Frequency			50	khz
R _o	Oscillator Resistor Range	30		150	kΩ
C _o	Oscillator Capacitor Range	470		2700	pF
C1	Starting Oscillator Capacitor Range	0.1		4.7	μF
C2	Repetitive Overload Protection Capacitor	1		22	μF
$ V_{in} $	Input Pulses Amplitude (peak) (derivated pulses - time constant = 1 μs)	0.5		1	V
T _{oper}	Operating Ambient Temperature	- 20		70	°C

2164-03.TBL

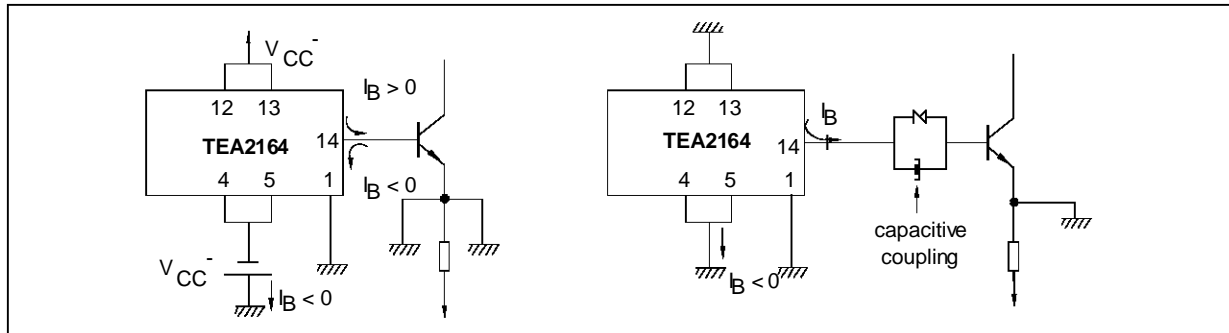

2164-05.EPS

ELECTRICAL OPERATING CHARACTERISTICS

T_{amb} = 25°C, V_{CC} = 10V, V_{CC-} = 0V, potentials referenced to ground (Pin 1)
(unless otherwise specified)

Symbol	Parameter	Min.	Typ.	Max.	Unit
POWER SUPPLY					
V _{CC} (start)	Starting Voltage (V _{CC} increasing)	8	9	9.6	V
V _{CC} (stop)	Stopping Voltage (V _{CC} decreasing)	5	6.2	7.4	V
ΔV _{CC}	Hysteresis (V _{CC} start – V _{CC} stop)	2	2.8	3.5	V
V _{CCmax}	Overvoltage Lock-out	14.8	15.5	16.2	V
I _{CCstart}	Starting Positive Supply Current	0.5	0.8	1.5	mA

CURRENT LIMITATION AND PROTECTION (pin 11)

$ V_{CM1} $	Pulse by Pulse Current Limitation Threshold	720	840	970	mV
$ V_{CM2} $	Current Monitoring 2nd Threshold	1200	1350	1500	mV
ΔV _{CM}	ΔV _{CM} = $ V_{CM2} - V_{CM1} $	300	500	700	mV

REPETITIVE OVERCURRENT PROTECTION

$ V_{CM3} $	Repetitive Overcurrent Threshold (pin 11)	700	900	1100	mV
V _{CM3} -V _{CM1}	(V _{CM3} -V _{CM1})	- 20	50	130	mV
V _{C2}	Lock-out Voltage on Pin 3	2.4	3	3.6	V
I ₃ disch	Capacitor C2 Discharge Current (synchronized mode)	10	20	30	μA
I ₃ ch.	Capacitor C2 Charge Current	50	80	110	μA

OSCILLATOR, MAX DUTY CYCLE, SYNCHRONIZATION

T _o	Oscillator Initial Accuracy RT = 50 K, CT = 1 nF	19.3	21	22.7	μs
T _{on(max)}	Maximum Duty Cycle (T _{syn} = 1.05 T _o)	60	70	85	%

2164-04.TBL

ELECTRICAL OPERATING CHARACTERISTICS (continued)

Symbol	Parameter	Min.	Typ.	Max.	Unit
OSCILLATOR, MAX DUTY CYCLE, SYNCHRONIZATION (continued)					
$\frac{T_{syn}}{T_O}$	Synchronization Window	1.0		1.5	
OUTPUT STAGE					
I_{14}/I_2	I_c Copy Current Gain		1000		
I_{BON}	Base Current Starting Pulse		300		mA
VERY LOW FREQUENCY OSCILLATOR					
	Burst Duty Cycle		13		%

2164-05.TBL

I. FIELD OF APPLICATION

The TEA2164 control circuit has been designed primarily for discontinuous mode flyback built with a master-slave architecture, whatever the field of application.

But due to its capability to synchronize the transistor switching-off with an external signal (line flyback) and due to an adapted burst-mode operation for a low power stand-by operation, the TEA2164 offers a smart solution for monitors and TV sets applications.

Power supply main features :

- maximum output power 140W (transistor forced gain : 3.5)

- stand-by mode output power ($1W \leq P_{sb} \leq 6W$; efficiency > 50%)
- operating frequency up to 50kHz
- power-switch : bipolar transistor

Adapted master-circuit :

- Monitor application → TEA5170
- Standard TV application → TEA2028B
TEA2029C
TEA2128
TEA5170
- Digital TV application → TEA5170

(TEA2028B, TEA2029C and TEA2128 are deflection processors with built-in PWM generator).

Figure 2 : Master Slave Power Supply Architecture

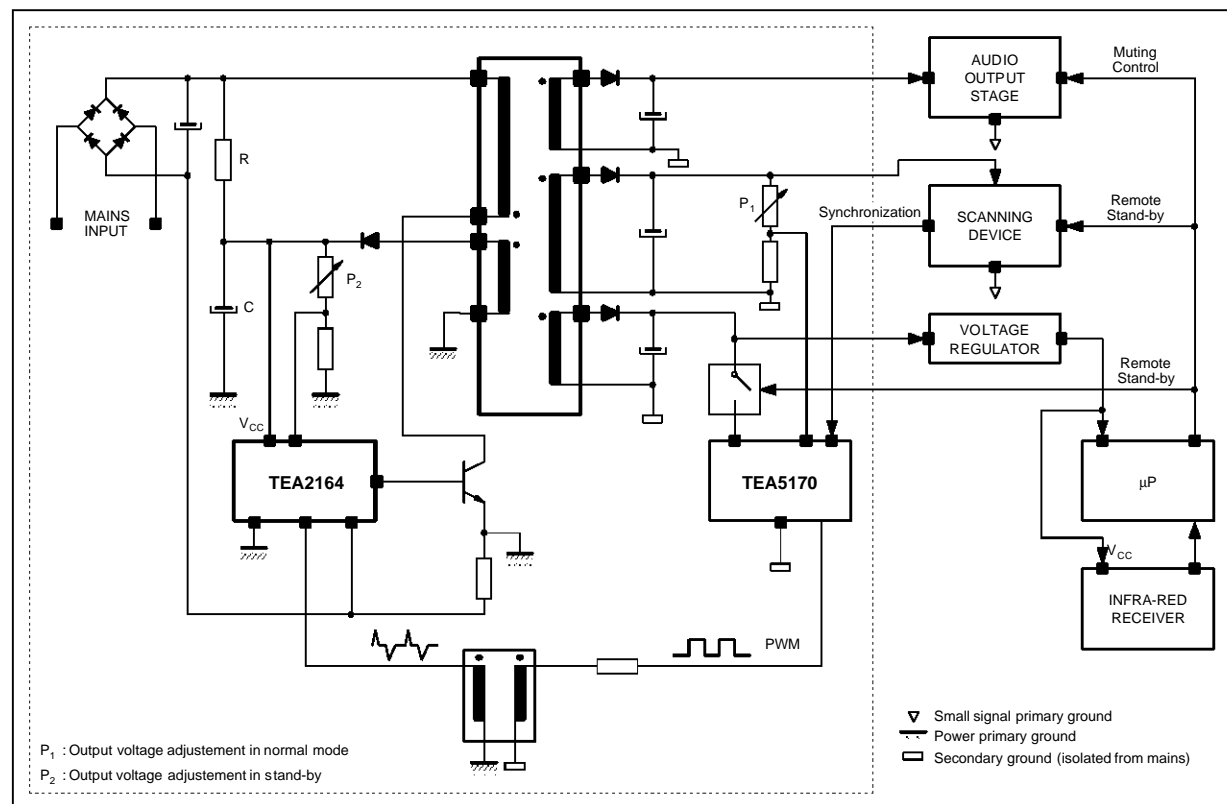

2164-06.EPS

II. GENERAL DESCRIPTION

In a master slave architecture, the TEA2164 Control IC, located at the primary side of an off line power supply achieves the slave function ; whereas

the master circuit is located at the secondary side. The link between both circuits is realized by a small pulse transformer (Figure 3).

Figure 3 : System Description Waveforms

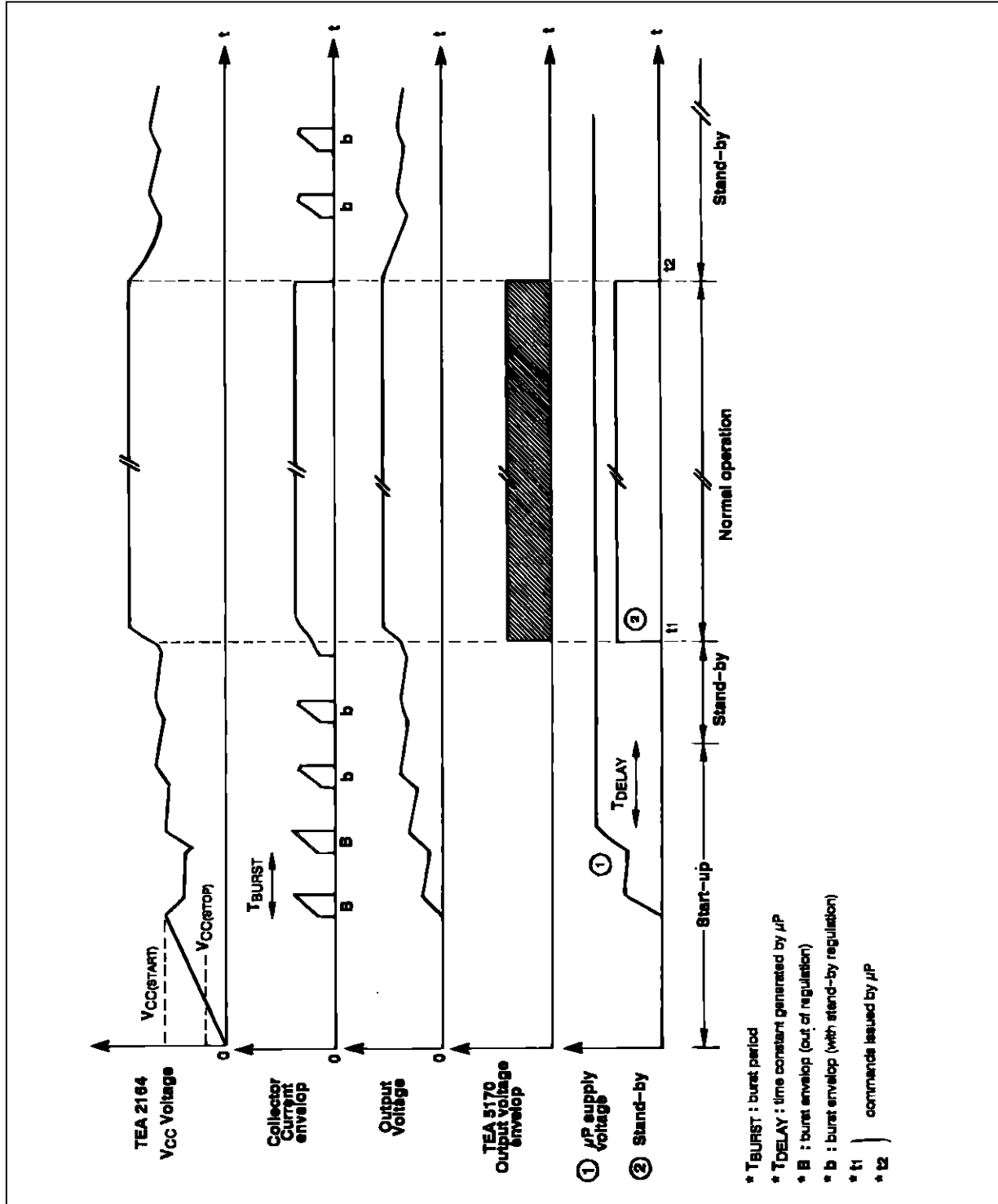

2164-07.EPS

In the operation of the master-slave architecture, four major cases must be considered :

- normal operating
- stand-by mode
- power supply start-up
- abnormal conditions : off load, short circuit, ...

II.1. Normal Operating (master slave mode)

In this configuration, the master circuit generates a pulse width modulated signal issued from the monitoring of the output voltage which needs the best accuracy (in TV applications : the horizontal deflection stage supply voltage). The master circuit power supply can be supplied by another output.

The PWM signal are sent towards the primary side through small differentiating transformer. For the TEA2164 positive pulses are transistor switching-on commands ; and negative pulses are transistor switching-off commands (Figure 4). In this configuration, only by synchronizing the master oscillator, the switching transistor may be synchronized with an external signal.

II.2. Stand-by Mode

In this configuration the master circuit no longer

sends PWM signals, the structure is not synchronized ; and the TEA2164 operates in burst mode. The average power consumption at the secondary side may be very low $1W \leq P \leq 6W$ (as it is consumed in TV set during stand by).

By action on the maximum duty cycle control, a primary loop maintains a semi-regulation of the output voltages. Voltage on feed-back is applied on Pin 9.

Burst period is externally programmed by capacitor C1.

II.3. Power Supply Start-up

After the mains have been switched-on, the V_{CC} storage capacitor of the TEA2164 is charged through a high value resistor connected to the rectified high voltage. When V_{CC} reaches V_{CC} start threshold (9V typ), the TEA2164 starts operating in burst mode. Since available output power is low in burst mode the output power consumption must remain low before complete setting-up of output voltage. In TV application it can be achieved by maintaining the TV in stand-by mode during start-up (Figure 6).

Figure 4 : Master Slave Mode Waveforms

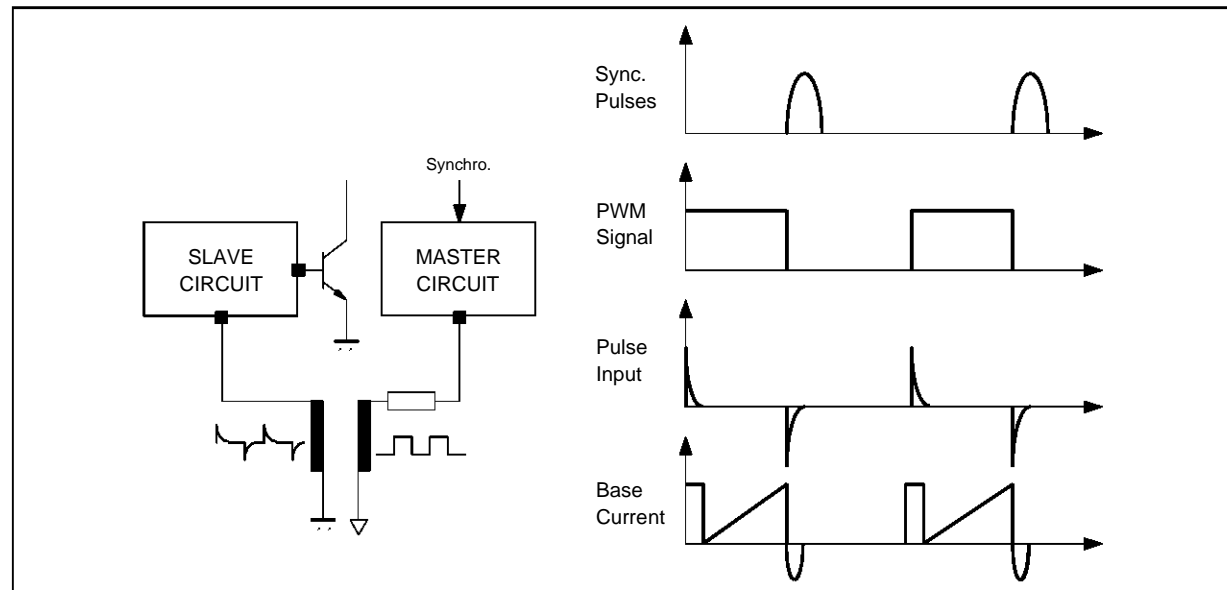

2164-08.EPS

Figure 5 : Burst Mode Waveforms

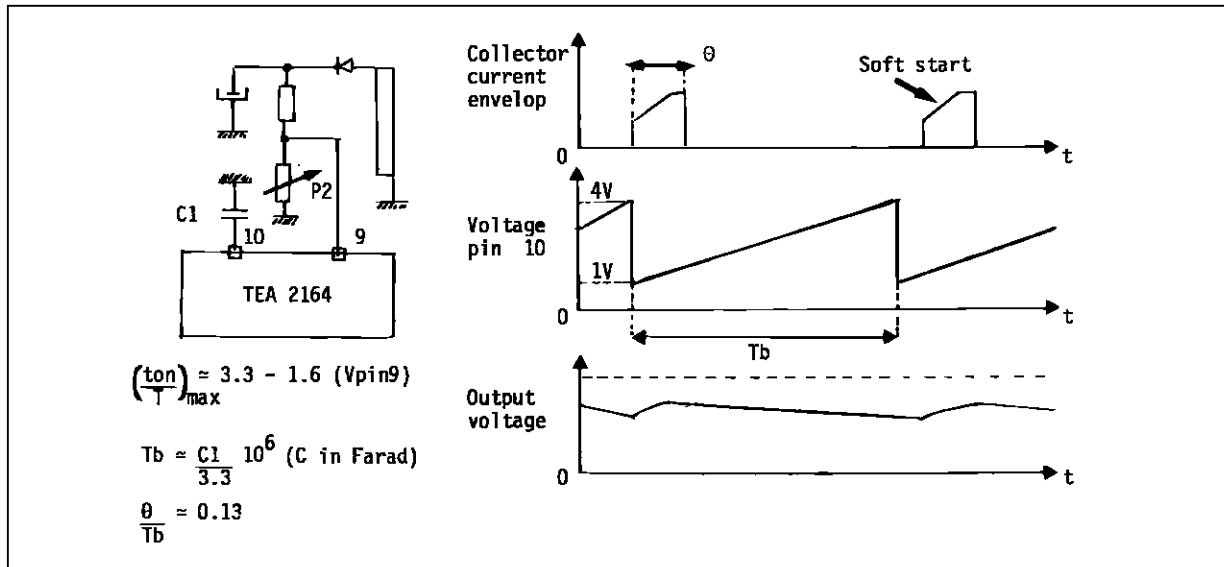

2164-09.EPS

Figure 6 : Power Supply Start-up

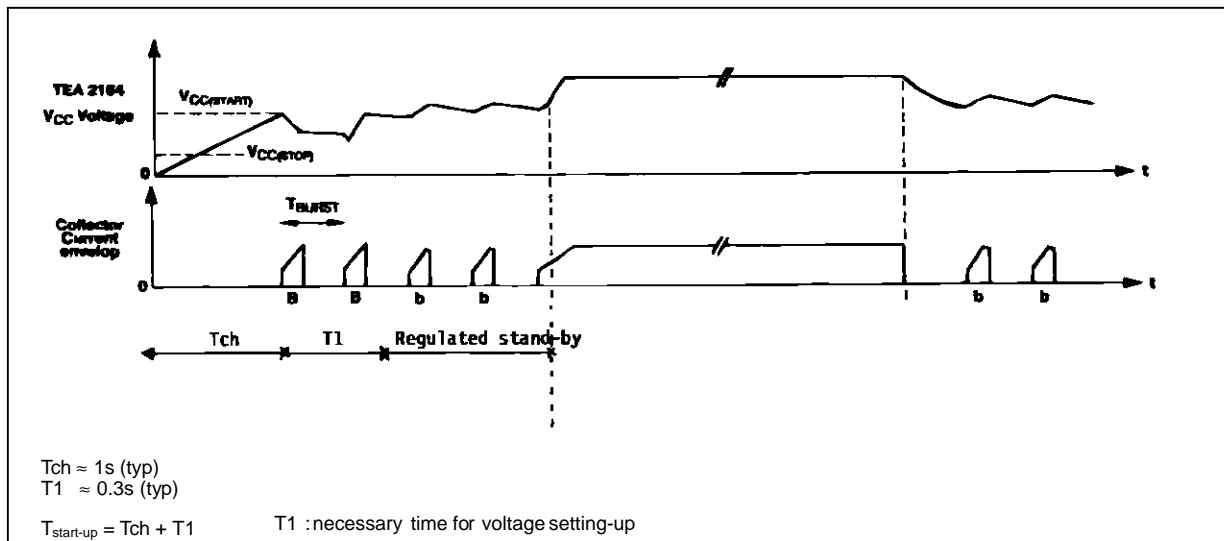

2164-10.EPS

d) Abnormal conditions : safety functions

Overvoltage Protection

When V_{CC} exceeds $V_{CC\ max}$, an internal flip-flop stops output conduction signals. The circuit will start again after the capacitor C_1 discharge ; it means : after loss of synchronization or after V_{CC} stop crossing (Figure 7).

In flyback converters, this function protects the power supply against output voltage runaway.

Under Voltage Lock-out

The TEA2164 control circuit stops operating when V_{CC} goes under $V_{CC\ stop}$.

Power Limitation, Current Protection, Long Duration Overload Protection

- Output power limitation : by a pulse by pulse collector current limitation the TEA2164 limits the maximum output power. V_{CM1} is the corresponding voltage threshold, its detection is memorized up to the next period.

- Current protection (transistor protection)

Under particular conditions a hard overload or short circuit may induce a flux runaway in spite of the current limitation (V_{CM1}).

The TEA2164 control circuit features a second current protection, V_{CM2} . When this threshold is reached an internal flip-flop memorizes it and

output conduction signals are inhibited. The circuit will send base drives again after capacitor C1 discharge (Figure 7).

- Long duration overload protection : (Figure 8)
An overload is detected when the sense-voltage on Pin 11 reaches V_{CM3} before a negative pulse has been applied to Pin 6. In this case the capacitor C2 (connected to Pin 3) is charged with I_3 ch up to the end of the period and discharged with I_3 disch until a next V_{CM3} detector. By this way in case of long duration overload, the capacitor

keeps charging at each period and its voltage increases gradually. When the voltage on Pin 3 exceeds V_{C2} , the TEA2164 control circuit stops sending base drives and memorizes this event. No restart is allowed as long as $V_{pin 3}$ is higher than V_{C2} and V_{CC} higher than 4.8V.

*** Remark :**

- The harder is the overload the faster is the protection
- The capacitor keeps charging between two burst after V_{CM2} detection.

Figure 7 : Overvoltages Lock-out

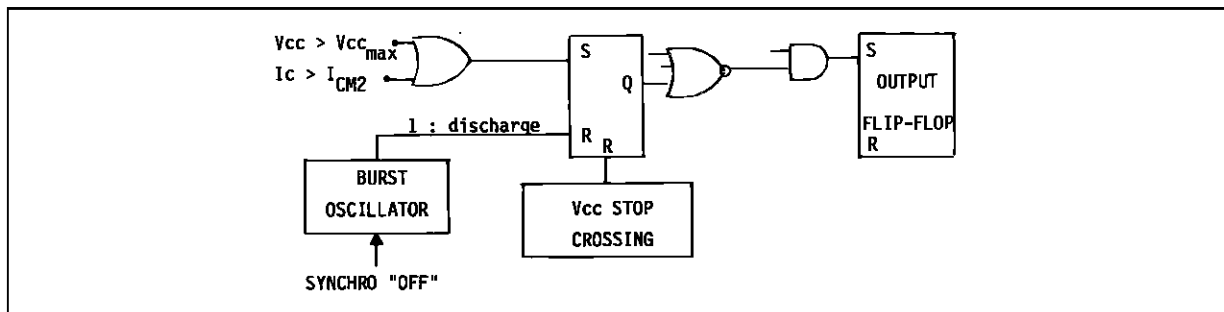

Figure 8 : Long Duration Overload Monitoring Circuit

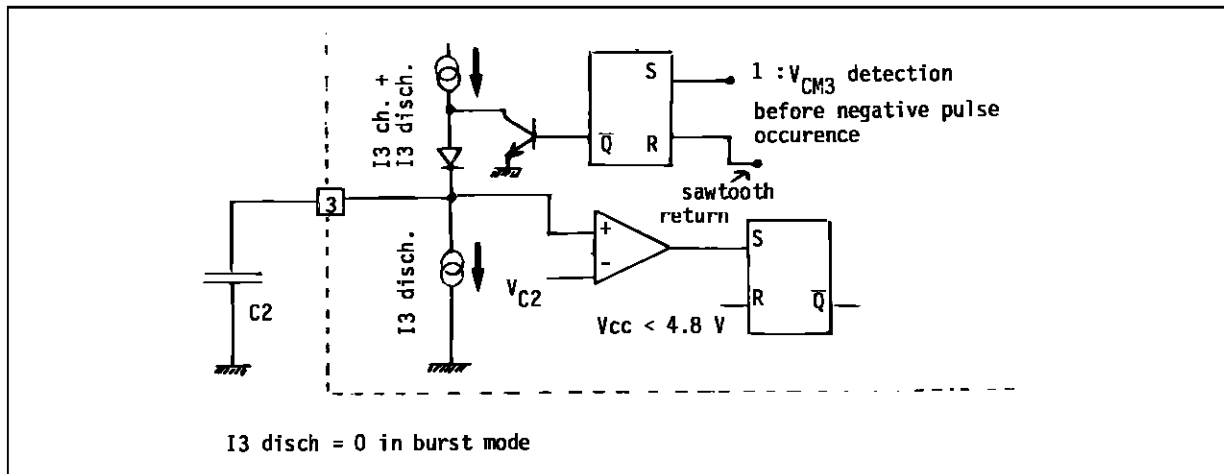

Figure 9 : Long Duration Overload Detection

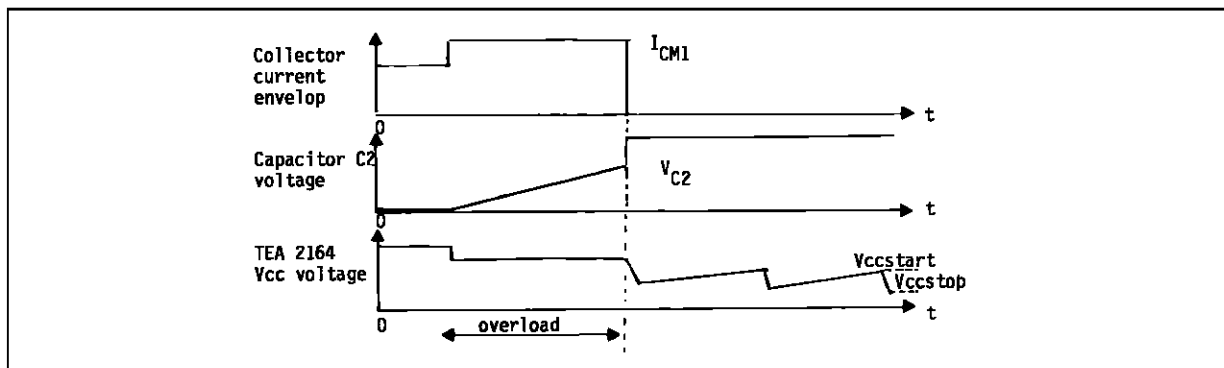
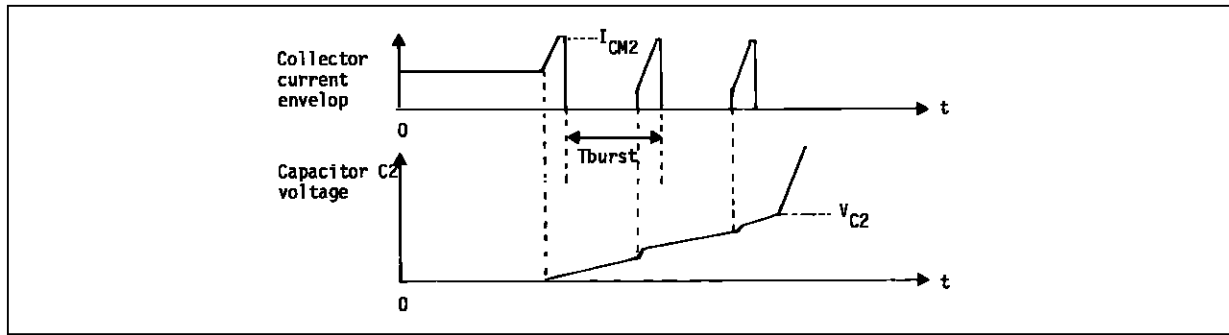

Figure 10 : Repetitive Over-current Protection



2164-14.EPS

III. SWITCHING OSCILLATOR AND SYNCHRONIZATION

III.1. Switching oscillator

When the TEA2164 control circuit operates in burst mode, the switching frequency is fixed by the free frequency oscillator. The period is determined by two external components C_o and R_o .

oscillators are not synchronous. In order to avoid any erratic conduction of the power transistor, the first synchronization pulse will arrive simultaneously with the sawtooth return of the TEA2164 oscillator.

III.2. Synchronization

When the master-circuit starts to send pulses both

To get synchronization the free frequency must be higher than the synchronization frequency.

$$T_o < T_{sync} < 1.50 T_o$$

Figure 11 : Free Frequency Running

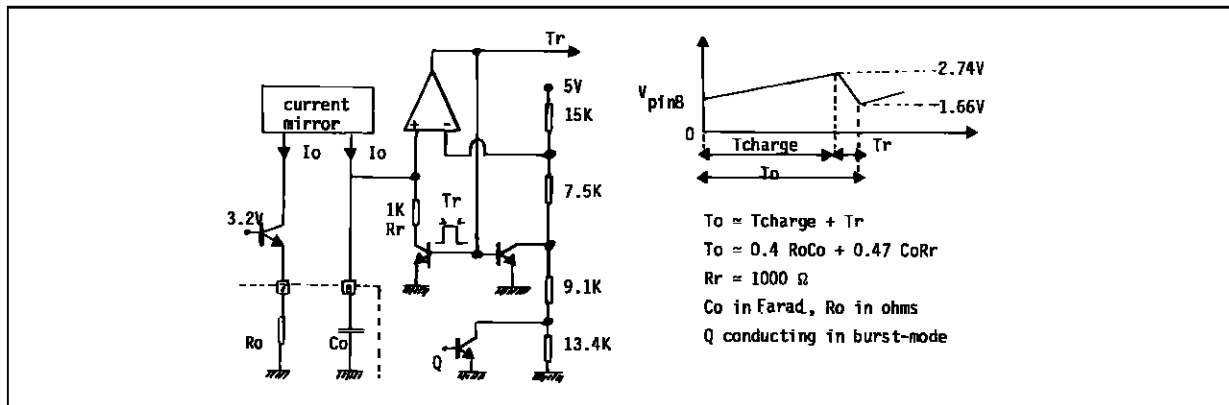

2164-15.EPS

Figure 12 : Synchronization Pulse Shaper and Synchronization

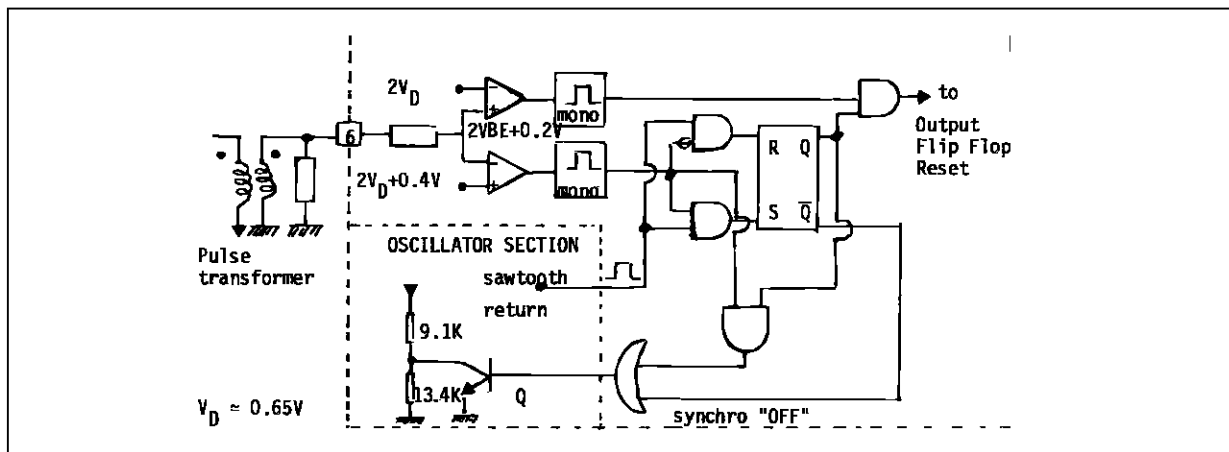

2164-16.EPS

Operation after synchronization

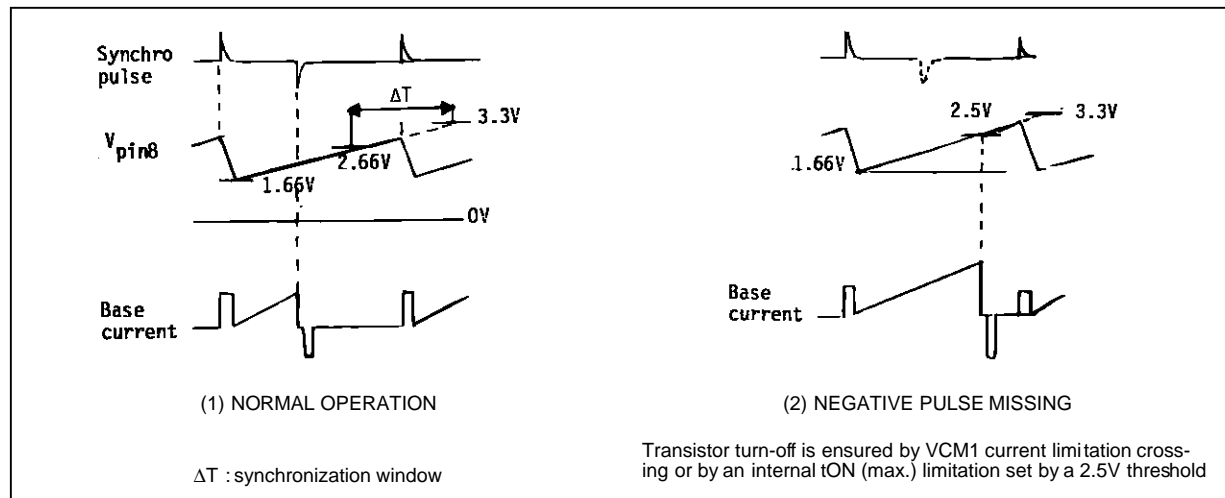

2164-17.EPS / 2164-18.EPS

Operation after synchronization

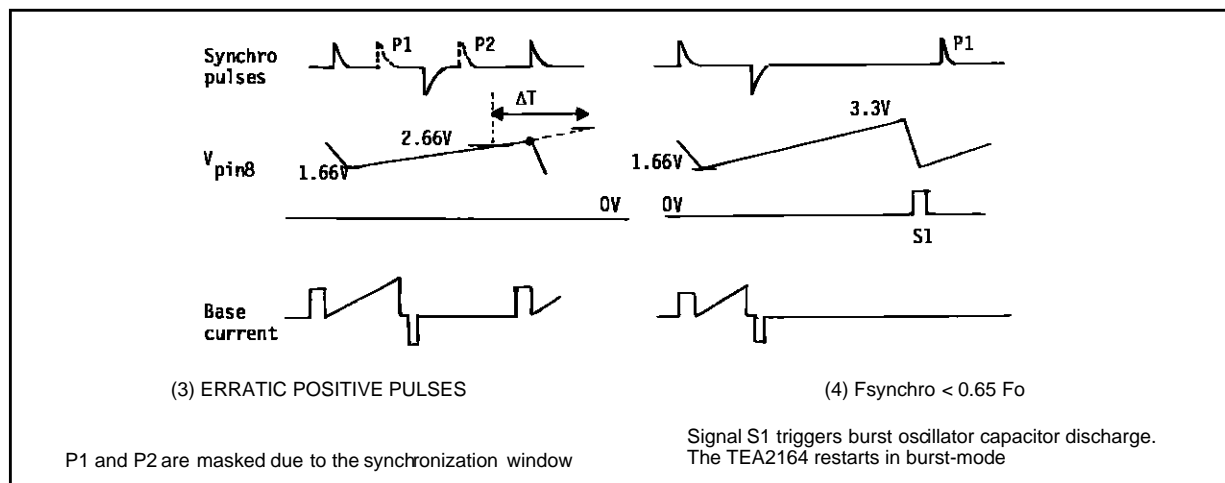

2164-19.EPS

Cases (2) (3) (4) do not occur in normal operating.

IV - MAXIMUM DUTY CYCLE LIMITATION

Burst mode : The maximum duty cycle is controlled by the voltage on Pin 9 (Figure 13).

Synchronized mode : Normally the maximum duty cycle is set by the master circuit. However the maximum conducting time will never exceed the value given by the comparison of the oscillator wave-form with the 2.5V internal threshold.

V - OUTPUT STAGE

TEA2164 output stage has been designed to drive switching bipolar transistor.

- Each base drive begins with a positive pulse I_{BON}

that realizes an efficient transistor turn-on.

- After the starting pulse I_{BON} , the base current is proportional to the collector current. The current gain is easily fixed by a resistor R (Figure 14).
- A fast and safe transistor turn-off is realized by a fast positive base current cut-off and by applying a negative base drive which draws stored carriers. A typical 0.7s delay prevents from cross-conduction of positive and negative output stages.

Remark : In order to reduce power dissipation on the positive output stage with the low gain transistors, for high base currents the positive output stage operates in saturated mode (Figure 15). This can be achieved by using a resistor between V_{CC} and V_+ .

Figure 13 : Maximum Duty Cycle Limitation

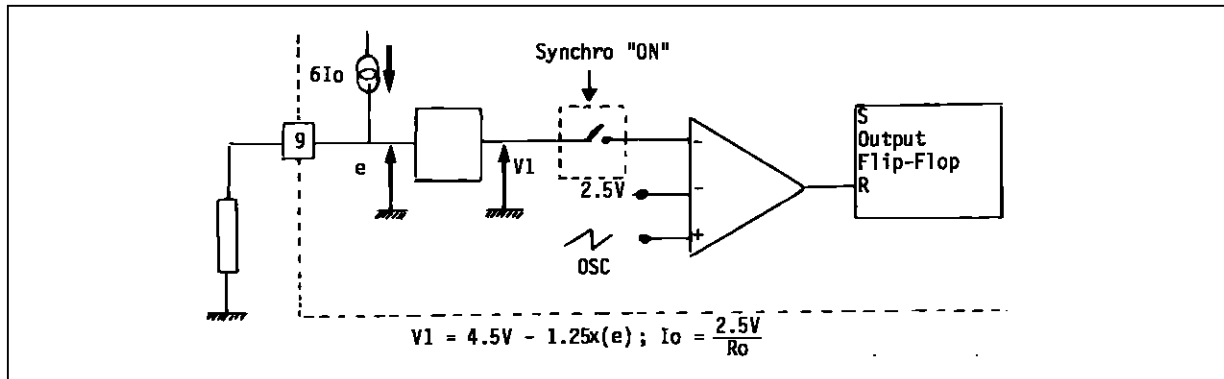

2164-20.EPS

Figure 14 : Output Stage Architecture and Base Drive

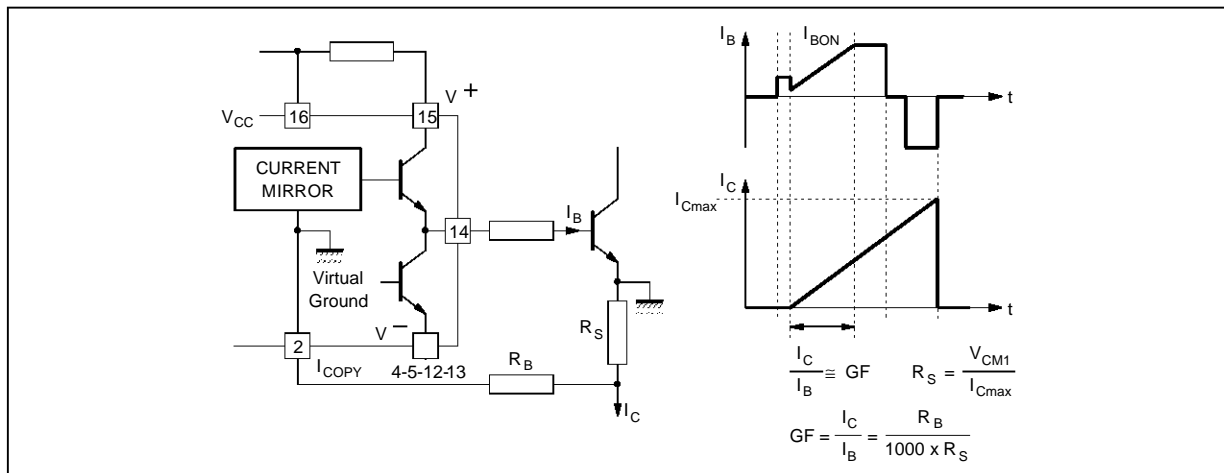

2164-21.EPS

VI - MONITOR APPLICATIONS

In most of monitor applications, the power supply must start-up under full load conditions and the stand-by mode is no longer useful.

The energy of the starting burst must be high enough to ensure start-up, then the capacitor C1 must be higher in these applications than on TV application (typ. : 1μF).

Figure 15 : Power Supply Start-up and Normal Operation

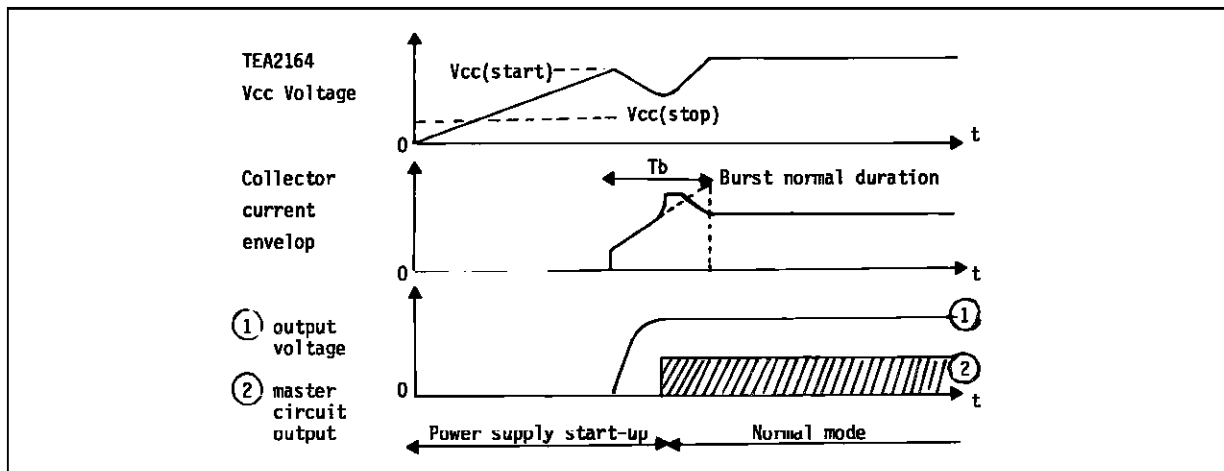

2164-22.EPS

COMPLETE APPLICATION DIAGRAM (SMPS + DEFLECTION) (with stand-by function)

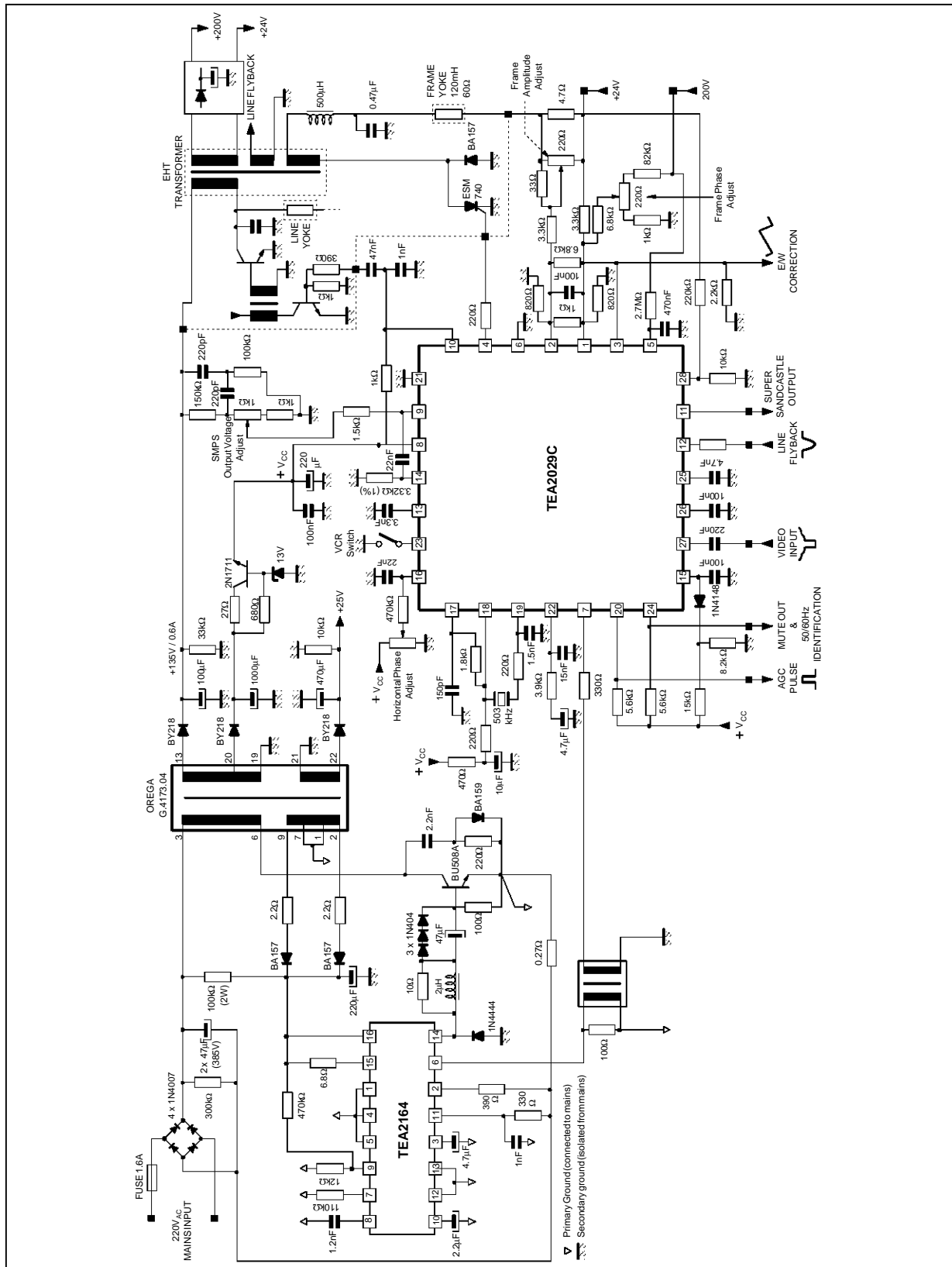

2164-23.EPS

PACKAGE MECHANICAL DATA
16 PINS - PLASTIC POWERDIP

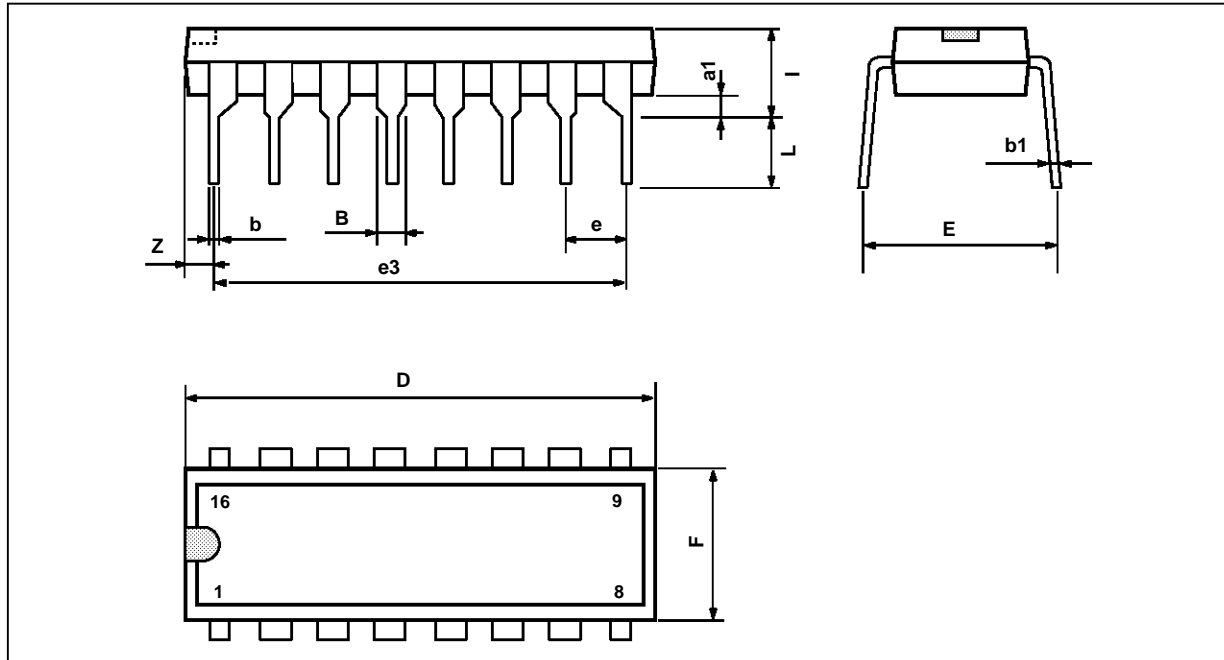

PMDIP16W.EPS

Dimensions	Millimeters			Inches		
	Min.	Typ.	Max.	Min.	Typ.	Max.
a1	0.51			0.020		
B	0.85		1.4	0.033		0.055
b		0.5			0.020	
b1	0.38		0.5	0.015		0.020
D			20			0.787
E		8.8			0.346	
e		2.54			0.100	
e3		17.78			0.700	
F			7.1			0.280
i			5.1			0.201
L		3.3			0.130	
Z			1.27			0.050

DIP16PW.TBL

Information furnished is believed to be accurate and reliable. However, SGS-THOMSON Microelectronics assumes no responsibility for the consequences of use of such information nor for any infringement of patents or other rights of third parties which may result from its use. No licence is granted by implication or otherwise under any patent or patent rights of SGS-THOMSON Microelectronics. Specifications mentioned in this publication are subject to change without notice. This publication supersedes and replaces all information previously supplied. SGS-THOMSON Microelectronics products are not authorized for use as critical components in life support devices or systems without express written approval of SGS-THOMSON Microelectronics.

© 1994 SGS-THOMSON Microelectronics - All Rights Reserved

Purchase of I²C Components of SGS-THOMSON Microelectronics, conveys a license under the Philips I²C Patent. Rights to use these components in a I²C system, is granted provided that the system conforms to the I²C Standard Specifications as defined by Philips.

SGS-THOMSON Microelectronics GROUP OF COMPANIES

Australia - Brazil - China - France - Germany - Hong Kong - Italy - Japan - Korea - Malaysia - Malta - Morocco
The Netherlands - Singapore - Spain - Sweden - Switzerland - Taiwan - Thailand - United Kingdom - U.S.A.