



Integrated Device Technology, Inc.

# FAST CMOS OCTAL TRANSCEIVER/REGISTERS (3-STATE)

IDT54/74FCT646T/AT/CT/DT - 2646T/AT/CT  
IDT54/74FCT648T/AT/CT  
IDT54/74FCT652T/AT/CT/DT - 2652T/AT/CT

## FEATURES:

- **Common features:**
  - Low input and output leakage  $\leq 1\mu\text{A}$  (max.)
  - Extended commercial range of  $-40^\circ\text{C}$  to  $+85^\circ\text{C}$
  - CMOS power levels
  - True TTL input and output compatibility
    - $V_{OH} = 3.3\text{V}$  (typ.)
    - $V_{OL} = 0.3\text{V}$  (typ.)
  - Meets or exceeds JEDEC standard 18 specifications
  - Product available in Radiation Tolerant and Radiation Enhanced versions
  - Military product compliant to MIL-STD-883, Class B and DESC listed (dual marked)
  - Available in DIP, SOIC, SSOP, QSOP, TSSOP, CERPACK and LCC packages
- **Features for FCT646T/648T/652T:**
  - Std., A, C and D speed grades
  - High drive outputs (-15mA IOH, 64mA IOL)
  - Power off disable outputs permit "live insertion"
- **Features for FCT2646T/2652T:**
  - Std., A, and C speed grades
  - Resistor outputs (-15mA IOH, 12mA IOL Com.) (-12mA IOH, 12mA IOL Mil.)
  - Reduced system switching noise

## DESCRIPTION:

The FCT646T/FCT2646T/FCT648T/FCT652T/2652T consist of a bus transceiver with 3-state D-type flip-flops and control circuitry arranged for multiplexed transmission of data directly from the data bus or from the internal storage registers.

The FCT652T/FCT2652T utilize GAB and  $\overline{\text{GBA}}$  signals to control the transceiver functions. The FCT646T/FCT2646T/FCT648T utilize the enable control ( $\overline{\text{G}}$ ) and direction (DIR) pins to control the transceiver functions.

SAB and SBA control pins are provided to select either real-time or stored data transfer. The circuitry used for select control will eliminate the typical decoding glitch that occurs in a multiplexer during the transition between stored and real-time data. A LOW input level selects real-time data and a HIGH selects stored data.

Data on the A or B data bus, or both, can be stored in the internal D flip-flops by LOW-to-HIGH transitions at the appropriate clock pins (CPAB or CPBA), regardless of the select or enable control pins.

The FCT26xxT have balanced drive outputs with current limiting resistors. This offers low ground bounce, minimal undershoot and controlled output fall times-reducing the need for external series terminating resistors. FCT2xxT parts are plug-in replacements for FCTxxxT parts.

## FUNCTIONAL BLOCK DIAGRAM

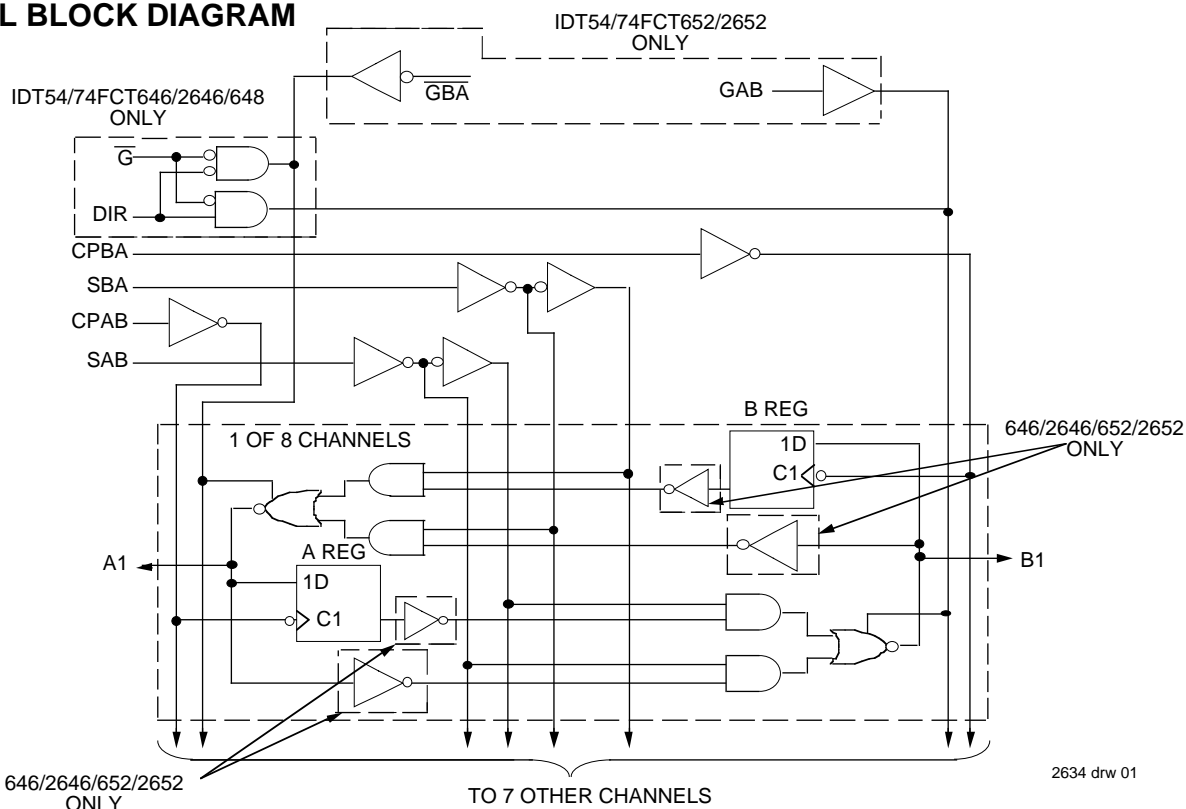

The IDT logo is a registered trademark of Integrated Device Technology, Inc.

MILITARY AND COMMERCIAL TEMPERATURE RANGES

SEPTEMBER 1996

**PIN CONFIGURATIONS**

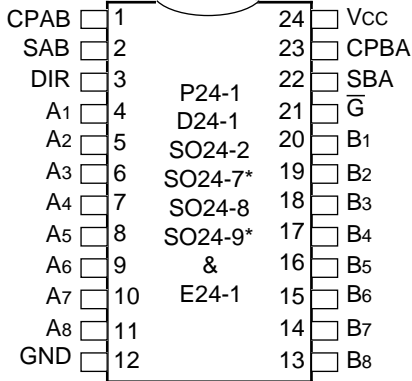

2634 drw 02

**DIP/SOIC/SSOP/  
QSOP/TSSOP/CERPACK  
TOP VIEW**

\* FCT646/2646T/AT/CT/DT only

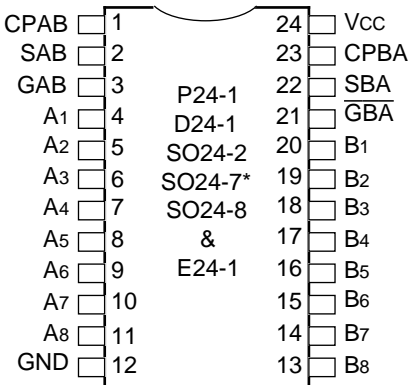

2634 drw 04

**DIP/SOIC/SSOP/  
QSOP/CERPACK  
TOP VIEW**

\* FCT652/2652T/AT/CT/DT only

**FCT646/FCT2646T  
FCT648**

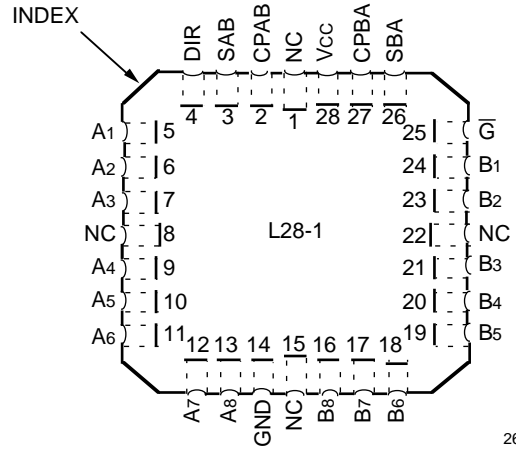

2634 drw 03

**LCC  
TOP VIEW**

**FCT652/FCT2652T**

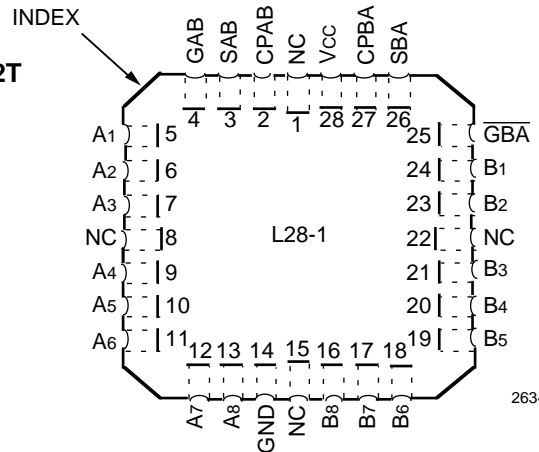

2634 drw 05

**LCC  
TOP VIEW**

**PIN DESCRIPTION**

Pin Names	Description
A1 - A8	Data Register A Inputs Data Register B Outputs
B1 - B8	Data Register B Inputs Data Register A Outputs
CPAB, CPBA	Clock Pulse Inputs
SAB, SBA	Output Data Source Select Inputs
DIR, $\bar{G}$	Output Enable Inputs (646/648)
GAB, $\bar{GBA}$	Output Enable Inputs (652)

2634 tbl 01

### FUNCTION TABLE (646/648)

Inputs						Data I/O <sup>(1)</sup>		Operation or Function	
$\overline{G}$	DIR	CPAB	CPBA	SAB	SBA	A <sub>1</sub> - A <sub>8</sub>	B <sub>1</sub> - B <sub>8</sub>	FCT646T/FCT2646T	FCT648T
H	X	H or L	H or L	X	X	Input	Input	Isolation	Isolation
H	X	↑	↑	X	X			Store A and B Data	Store A and B Data
L	L	X	X	X	L	Output	Input	Real-Time B Data to A Bus	Real-Time $\overline{B}$ Data to A Bus
L	L	X	H or L	X	H			Stored B Data to A Bus	Stored $\overline{B}$ Data to A Bus
L	H	X	X	L	X	Input	Output	Real-Time A Data to B Bus	Real-Time $\overline{A}$ Data to B Bus
L	H	H or L	X	H	X			Stored A Data to B Bus	Stored $\overline{A}$ Data to B Bus

2634 tbl 02

### FUNCTION TABLE (652)

Inputs						Data I/O		Operation or Function	
GAB	$\overline{GBA}$	CPAB	CPBA	SAB	SBA	A <sub>1</sub> - A <sub>8</sub>	B <sub>1</sub> - B <sub>8</sub>	FCT652T/FCT2652T	
L	H	H or L	H or L	X	X	Input	Input	Isolation	
L	H	↑	↑	X	X			Store A and B Data	
X	H	↑	H or L	X	X	Input	Unspecified <sup>(1)</sup>	Store A, Hold B	
H	H	↑	↑	X <sup>(2)</sup>	X	Input	Output	Store A in Both Registers	
L	X	H or L	↑	X	X	Unspecified <sup>(1)</sup>	Input	Hold A, Store B	
L	L	↑	↑	X	X <sup>(2)</sup>	Output	Input	Store B in Both Registers	
L	L	X	X	X	L	Output	Input	Real-Time B Data to A Bus	
L	L	X	H or L	X	H			Stored B Data to A Bus	
H	H	X	X	L	X	Input	Output	Real-Time A Data to B Bus	
H	H	H or L	X	H	X			Stored A Data to B Bus	
H	L	H or L	H or L	H	H	Output	Output	Stored A Data to B Bus and Stored B Data to A Bus	

**NOTES:**

2634 tbl 03

- The data output functions may be enabled or disabled by various signals at the GAB or GBA inputs. Data input functions are always enabled, i.e. data at the bus pins will be stored on every LOW-to-HIGH transition on the clock inputs.
- Select control = L: clocks can occur simultaneously.  
Select control = H: clocks must be staggered in order to load both registers.  
H = HIGH, L = LOW, X = Don't Care, ↑ = LOW-to-HIGH transition.
- $\overline{A}$  in B Register.
- $\overline{B}$  in A Register.

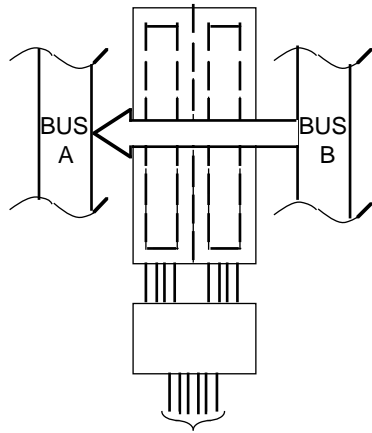

652/2652	GAB	$\overline{\text{GBA}}$	CPAB	CPBA	SAB	SBA
	L	L	X	X	X	L
646/2646/ 648	DIR	$\overline{\text{G}}$	CPAB	CPBA	SAB	SBA
	L	L	X	X	X	L

REAL-TIME TRANSFER  
BUS B TO A

2634 drw 06

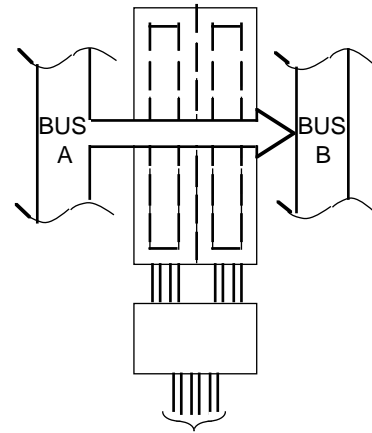

652/2652	GAB	$\overline{\text{GBA}}$	CPAB	CPBA	SAB	SBA
	H	H	X	X	L	X
646/2646/ 648	DIR	$\overline{\text{G}}$	CPAB	CPBA	SAB	SBA
	H	L	X	X	L	X

REAL-TIME TRANSFER  
BUS A TO B

2634 drw 07

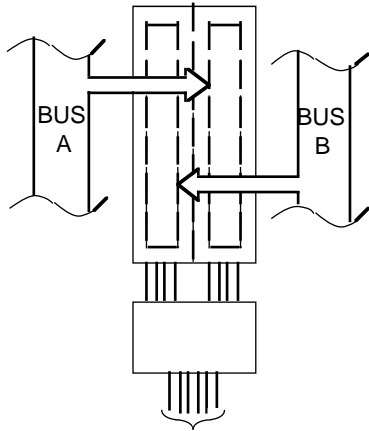

652/2652	GAB	$\overline{\text{GBA}}$	CPAB	CPBA	SAB	SBA
	X	H	↑	X	X	X
	L	X	X	↑	X	X
	L	H	↑	↑	X	X
646/2646/ 648	DIR	$\overline{\text{G}}$	CPAB	CPBA	SAB	SBA
	H	L	↑	X	X	X
	L	L	X	↑	X	X
	X	H	↑	↑	X	X

STORAGE FROM  
A AND/OR B

2634 drw 08

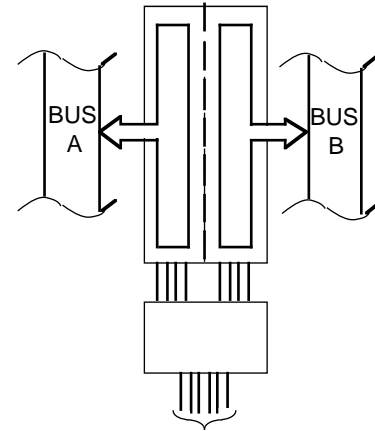

652/2652	GAB	$\overline{\text{GBA}}$	CPAB	CPBA	SAB	SBA
	H	L	H or	H or	H	H
646/2646/ <sup>(1)</sup> 648	DIR	$\overline{\text{G}}$	CPAB	CPBA	SAB	SBA
	L	L	X	H or	X	H
	H	L	H or	X	H	X

TRANSFER STORES  
DATA TO A AND/OR B

2634 drw 09

**NOTE:**

1. 646/2646/648 cannot transfer data to A bus and B bus simultaneously.

## ABSOLUTE MAXIMUM RATINGS<sup>(1)</sup>

Symbol	Description	Max.	Unit
VTERM <sup>(2)</sup>	Terminal Voltage with Respect to GND	-0.5 to +7.0	V
VTERM <sup>(3)</sup>	Terminal Voltage with Respect to GND	-0.5 to V <sub>CC</sub> +0.5	V
TSTG	Storage Temperature	-65 to +150	°C
IOUT	DC Output Current	-60 to +120	mA

### NOTES:

2634 Ink 04

- Stresses greater than those listed under ABSOLUTE MAXIMUM RATINGS may cause permanent damage to the device. This is a stress rating only and functional operation of the device at these or any other conditions above those indicated in the operational sections of this specification is not implied. Exposure to absolute maximum rating conditions for extended periods may affect reliability. No terminal voltage may exceed V<sub>CC</sub> by +0.5V unless otherwise noted.
- Input and V<sub>CC</sub> terminals only.
- Outputs and I/O terminals only.

## CAPACITANCE (T<sub>A</sub> = +25°C, f = 1.0MHz)

Symbol	Parameter <sup>(1)</sup>	Conditions	Typ.	Max.	Unit
C <sub>IN</sub>	Input Capacitance	V <sub>IN</sub> = 0V	6	10	pF
C <sub>OUT</sub>	Output Capacitance	V <sub>OUT</sub> = 0V	8	12	pF

### NOTE:

2634 Ink 05

- This parameter is measured at characterization but not tested.

## DC ELECTRICAL CHARACTERISTICS OVER OPERATING RANGE

Following Conditions Apply Unless Otherwise Specified:

Commercial: T<sub>A</sub> = -40°C to +85°C, V<sub>CC</sub> = 5.0V ± 5%; Military: T<sub>A</sub> = -55°C to +125°C, V<sub>CC</sub> = 5.0V ± 10%

Symbol	Parameter	Test Conditions <sup>(1)</sup>	Min.	Typ. <sup>(2)</sup>	Max.	Unit
V <sub>IH</sub>	Input HIGH Level	Guaranteed Logic HIGH Level	2.0	—	—	V
V <sub>IL</sub>	Input LOW Level	Guaranteed Logic LOW Level	—	—	0.8	V
I <sub>IH</sub>	Input HIGH Current <sup>(4)</sup>	V <sub>CC</sub> = Max. V <sub>I</sub> = 2.7V	—	—	±1	μA
I <sub>IL</sub>	Input LOW Current <sup>(4)</sup>		V <sub>I</sub> = 0.5V	—	—	
I <sub>OZH</sub>	High Impedance Output Current (3-State Output pins) <sup>(4)</sup>	V <sub>CC</sub> = Max. V <sub>O</sub> = 2.7V	—	—	±1	μA
I <sub>OZL</sub>			V <sub>O</sub> = 0.5V	—	—	
I <sub>I</sub>	Input HIGH Current <sup>(4)</sup>	V <sub>CC</sub> = Max., V <sub>I</sub> = V <sub>CC</sub> (Max.)	—	—	±1	μA
V <sub>IK</sub>	Clamp Diode Voltage	V <sub>CC</sub> = Min., I <sub>IN</sub> = -18mA	—	-0.7	-1.2	V
V <sub>H</sub>	Input Hysteresis	—	—	200	—	mV
I <sub>CC</sub>	Quiescent Power Supply Current	V <sub>CC</sub> = Max., V <sub>IN</sub> = GND or V <sub>CC</sub>	—	0.01	1	mA

2634 Ink 05

## OUTPUT DRIVE CHARACTERISTICS FOR FCT646T/648T/652T

Symbol	Parameter	Test Conditions <sup>(1)</sup>	Min.	Typ. <sup>(2)</sup>	Max.	Unit	
V <sub>OH</sub>	Output HIGH Voltage	V <sub>CC</sub> = Min. V <sub>IN</sub> = V <sub>IH</sub> or V <sub>IL</sub>	I <sub>OH</sub> = -6mA MIL.	2.4	3.3	—	V
			I <sub>OH</sub> = -8mA COM'L.	—	—	—	—
V <sub>OL</sub>	Output LOW Voltage	V <sub>CC</sub> = Min. V <sub>IN</sub> = V <sub>IH</sub> or V <sub>IL</sub>	I <sub>OL</sub> = -12mA MIL.	2.0	3.0	—	V
			I <sub>OL</sub> = -15mA COM'L.	—	—	—	—
I <sub>OS</sub>	Short Circuit Current	V <sub>CC</sub> = Max., V <sub>O</sub> = GND <sup>(3)</sup>	-60	-120	-225	mA	
I <sub>OFF</sub>	Input/Output Power Off Leakage <sup>(5)</sup>	V <sub>CC</sub> = 0V, V <sub>IN</sub> or V <sub>O</sub> ≤ 4.5V	—	—	±1	μA	

2634 Ink 06

## OUTPUT DRIVE CHARACTERISTICS FOR FCT2646T/2652T

Symbol	Parameter	Test Conditions <sup>(1)</sup>		Min.	Typ. <sup>(2)</sup>	Max.	Unit
I <sub>ODL</sub>	Output LOW Current	V <sub>CC</sub> = 5V, V <sub>IN</sub> = V <sub>IH</sub> or V <sub>IL</sub> , V <sub>OUT</sub> = 1.5V <sup>(3)</sup>		16	48	—	mA
I <sub>ODH</sub>	Output HIGH Current	V <sub>CC</sub> = 5V, V <sub>IN</sub> = V <sub>IH</sub> or V <sub>IL</sub> , V <sub>OUT</sub> = 1.5V <sup>(3)</sup>		-16	-48	—	mA
V <sub>OH</sub>	Output HIGH Voltage	V <sub>CC</sub> = Min. V <sub>IN</sub> = V <sub>IH</sub> or V <sub>IL</sub>	I <sub>OH</sub> = -12mA MIL. I <sub>OH</sub> = -15mA COM'L.	2.4	3.3	—	V
V <sub>OL</sub>	Output LOW Voltage	V <sub>CC</sub> = Min. V <sub>IN</sub> = V <sub>IH</sub> or V <sub>IL</sub>	I <sub>OL</sub> = 12mA	—	0.3	0.50	V

### NOTES:

2634 Ink 07

- For conditions shown as Max. or Min., use appropriate value specified under Electrical Characteristics for the applicable device type.
- Typical values are at V<sub>CC</sub> = 5.0V, +25°C ambient.
- Not more than one output should be shorted at one time. Duration of the short circuit test should not exceed one second.
- The test limit for this parameter is ±5μA at T<sub>A</sub> = -55°C.
- This parameter is guaranteed but not tested.

## POWER SUPPLY CHARACTERISTICS

Symbol	Parameter	Test Conditions <sup>(1)</sup>		Min.	Typ. <sup>(2)</sup>	Max.	Unit	
ΔI <sub>CC</sub>	Quiescent Power Supply Current TTL Inputs HIGH	V <sub>CC</sub> = Max. V <sub>IN</sub> = 3.4V <sup>(3)</sup>		—	0.5	2.0	mA	
I <sub>CCD</sub>	Dynamic Power Supply Current <sup>(4)</sup>	V <sub>CC</sub> = Max. Outputs Open GAB = $\overline{\text{GBA}}$ = GND or $\overline{\text{G}}$ = DIR = GND One Input Toggling 50% Duty Cycle	V <sub>IN</sub> = V <sub>CC</sub> V <sub>IN</sub> = GND	FCTxxxT	—	0.15	0.25	mA/ MHz
				FCT2xxxT	—	0.06	0.12	
I <sub>C</sub>	Total Power Supply Current <sup>(6)</sup>	V <sub>CC</sub> = Max. Outputs Open f <sub>CP</sub> = 10MHz 50% Duty Cycle GAB = $\overline{\text{GBA}}$ = GND or $\overline{\text{G}}$ = DIR = GND One Bit Toggling at f <sub>i</sub> = 5MHz 50% Duty Cycle	V <sub>IN</sub> = V <sub>CC</sub> V <sub>IN</sub> = GND	FCTxxxT	—	1.5	3.5	mA
				FCT2xxxT	—	0.6	2.2	
		V <sub>CC</sub> = Max. Outputs Open f <sub>CP</sub> = 10MHz 50% Duty Cycle GAB = $\overline{\text{GBA}}$ = GND or $\overline{\text{G}}$ = DIR = GND Eight Bits Toggling at f <sub>i</sub> = 2.5MHz 50% Duty Cycle	V <sub>IN</sub> = 3.4 V <sub>IN</sub> = GND	FCTxxxT	—	2.0	5.5	
				FCT2xxxT	—	1.1	4.2	
		V <sub>CC</sub> = Max. Outputs Open f <sub>CP</sub> = 10MHz 50% Duty Cycle GAB = $\overline{\text{GBA}}$ = GND or $\overline{\text{G}}$ = DIR = GND Eight Bits Toggling at f <sub>i</sub> = 2.5MHz 50% Duty Cycle	V <sub>IN</sub> = V <sub>CC</sub> V <sub>IN</sub> = GND	FCTxxxT	—	3.8	7.3 <sup>(5)</sup>	
				FCT2xxxT	—	1.5	4.0 <sup>(5)</sup>	
		V <sub>IN</sub> = 3.4 V <sub>IN</sub> = GND	FCTxxxT	—	6.0	16.3 <sup>(5)</sup>		
			FCT2xxxT	—	3.8	13.0 <sup>(5)</sup>		

### NOTES:

2634 tbl 08

- For conditions shown as Max. or Min., use appropriate value specified under Electrical Characteristics for the applicable device type.
- Typical values are at V<sub>CC</sub> = 5.0V, +25°C ambient.
- Per TTL driven input (V<sub>IN</sub> = 3.4V). All other inputs at V<sub>CC</sub> or GND.
- This parameter is not directly testable, but is derived for use in Total Power Supply Calculations.
- Values for these conditions are examples of the I<sub>CC</sub> formula. These limits are guaranteed but not tested.
- I<sub>C</sub> = I<sub>QUIESCENT</sub> + I<sub>INPUTS</sub> + I<sub>DYNAMIC</sub>  
 $I_C = I_{CC} + \Delta I_{CC} \text{DHNT} + I_{CCD} (f_{CP}/2 + f_i N_i)$   
 I<sub>CC</sub> = Quiescent Current  
 ΔI<sub>CC</sub> = Power Supply Current for a TTL High Input (V<sub>IN</sub> = 3.4V)  
 DH = Duty Cycle for TTL Inputs High  
 NT = Number of TTL Inputs at DH  
 I<sub>CCD</sub> = Dynamic Current Caused by an Input Transition Pair (HLH or LHL)  
 f<sub>CP</sub> = Clock Frequency for Register Devices (Zero for Non-Register Devices)  
 f<sub>i</sub> = Input Frequency  
 N<sub>i</sub> = Number of Inputs at f<sub>i</sub>  
 All currents are in milliamps and all frequencies are in megahertz.

**SWITCHING CHARACTERISTICS OVER OPERATING RANGE**

Symbol	Parameter	Condition <sup>(1)</sup>	646/648/652T 2646/2652T				646/648/652AT 2646/2652AT				Unit
			Com'l.		Mil.		Com'l.		Mil.		
			Min. <sup>(2)</sup>	Max.	Min. <sup>(2)</sup>	Max.	Min. <sup>(2)</sup>	Max.	Min. <sup>(2)</sup>	Max.	
tPLH tPHL	Propagation Delay Bus to Bus	CL = 50pF RL = 500Ω	2.0	9.0	2.0	11.0	2.0	6.3	2.0	7.7	ns
tpZH tpZL	Output Enable Time, $\overline{G}$ , DIR to Bus <sup>(3)</sup>		2.0	14.0	2.0	15.0	2.0	9.8	2.0	10.5	ns
tpHZ tPLZ	Output Disable Time, $\overline{G}$ , DIR to Bus <sup>(3)</sup>		2.0	9.0	2.0	11.0	2.0	6.3	2.0	7.7	ns
tPLH tPHL	Propagation Delay Clock to Bus		2.0	9.0	2.0	10.0	2.0	6.3	2.0	7.0	ns
tPLH tPHL	Propagation Delay SBA or SAB to Bus		2.0	11.0	2.0	12.0	2.0	7.7	2.0	8.4	ns
tsu	Set-up Time HIGH or LOW Bus to Clock		4.0	—	4.5	—	2.0	—	2.0	—	ns
th	Hold Time HIGH or LOW Bus to Clock		2.0	—	2.0	—	1.5	—	1.5	—	ns
tw	Clock Pulse Width, HIGH or LOW		6.0	—	6.0	—	5.0	—	5.0	—	ns

2634 tbl 09

Symbol	Parameter	Condition <sup>(1)</sup>	646/648/652CT 2646/2652CT				646/652DT				Unit
			Com'l.		Mil.		Com'l.		Mil.		
			Min. <sup>(2)</sup>	Max.	Min. <sup>(2)</sup>	Max.	Min. <sup>(2)</sup>	Max.	Min. <sup>(2)</sup>	Max.	
tPLH tPHL	Propagation Delay Bus to Bus	CL = 50pF RL = 500Ω	1.5	5.4	1.5	6.0	1.5	4.4	—	—	ns
tpZH tpZL	Output Enable Time, $\overline{G}$ , DIR to Bus <sup>(3)</sup>		1.5	7.8	1.5	8.9	1.5	5.0	—	—	ns
tpHZ tPLZ	Output Disable Time, $\overline{G}$ , DIR to Bus <sup>(3)</sup>		1.5	6.3	1.5	7.7	1.5	4.3	—	—	ns
tPLH tPHL	Propagation Delay Clock to Bus		1.5	5.7	1.5	6.3	1.5	4.4	—	—	ns
tPLH tPHL	Propagation Delay SBA or SAB to Bus		1.5	6.2	1.5	7.0	1.5	5.0	—	—	ns
tsu	Set-up Time HIGH or LOW Bus to Clock		2.0	—	2.0	—	1.5	—	—	—	ns
th	Hold Time HIGH or LOW Bus to Clock		1.5	—	1.5	—	1.0	—	—	—	ns
tw	Clock Pulse Width, HIGH or LOW <sup>(4)</sup>		5.0	—	5.0	—	3.0	—	—	—	ns

**NOTES:**

1. See test circuit and waveforms.
2. Minimum limits are guaranteed but not tested on Propagation Delays.
3. GAB,  $\overline{G}$ BA to Bus for 652.
4. This parameter is guaranteed but not tested.

2634 tbl 10

## TEST CIRCUITS AND WAVEFORMS

### TEST CIRCUITS FOR ALL OUTPUTS

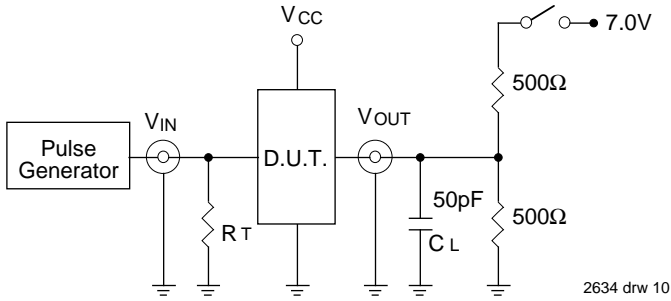

### SWITCH POSITION

Test	Switch
Open Drain Disable Low Enable Low	Closed
All Other Tests	Open

#### DEFINITIONS:

CL = Load capacitance: includes jig and probe capacitance.  
RT = Termination resistance: should be equal to Z<sub>OUT</sub> of the Pulse Generator.

2634 Ink 11

### SET-UP, HOLD AND RELEASE TIMES

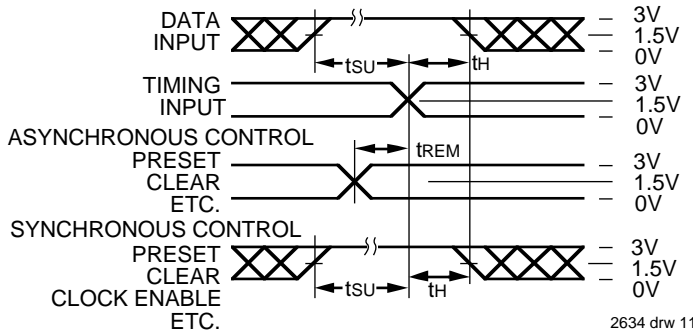

### PULSE WIDTH

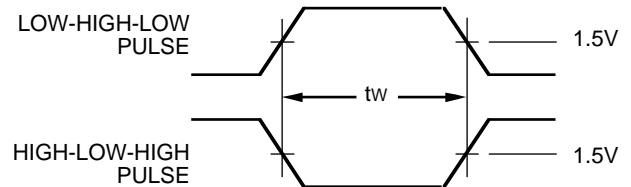

### PROPAGATION DELAY

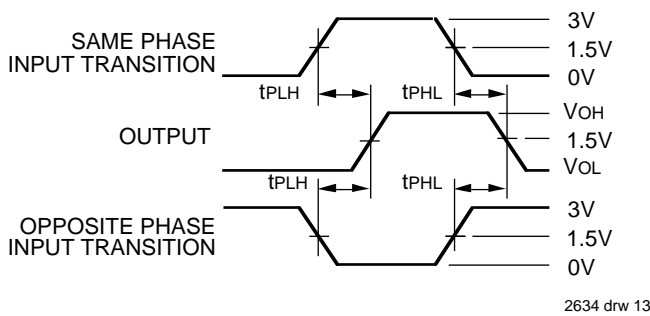

### ENABLE AND DISABLE TIMES

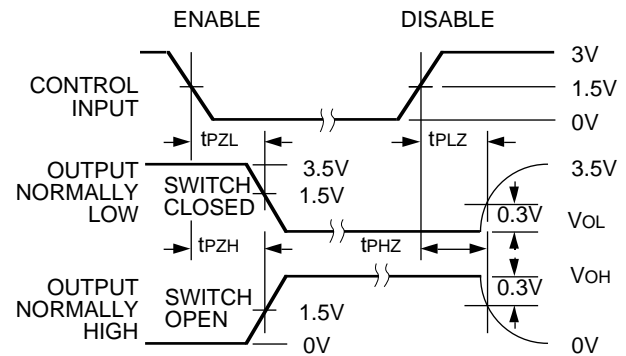

#### NOTES:

- Diagram shown for input Control Enable-LOW and input Control Disable-HIGH
- Pulse Generator for All Pulses: Rate ≤ 1.0MHz; t<sub>f</sub> ≤ 2.5ns; t<sub>r</sub> ≤ 2.5ns

## ORDERING INFORMATION

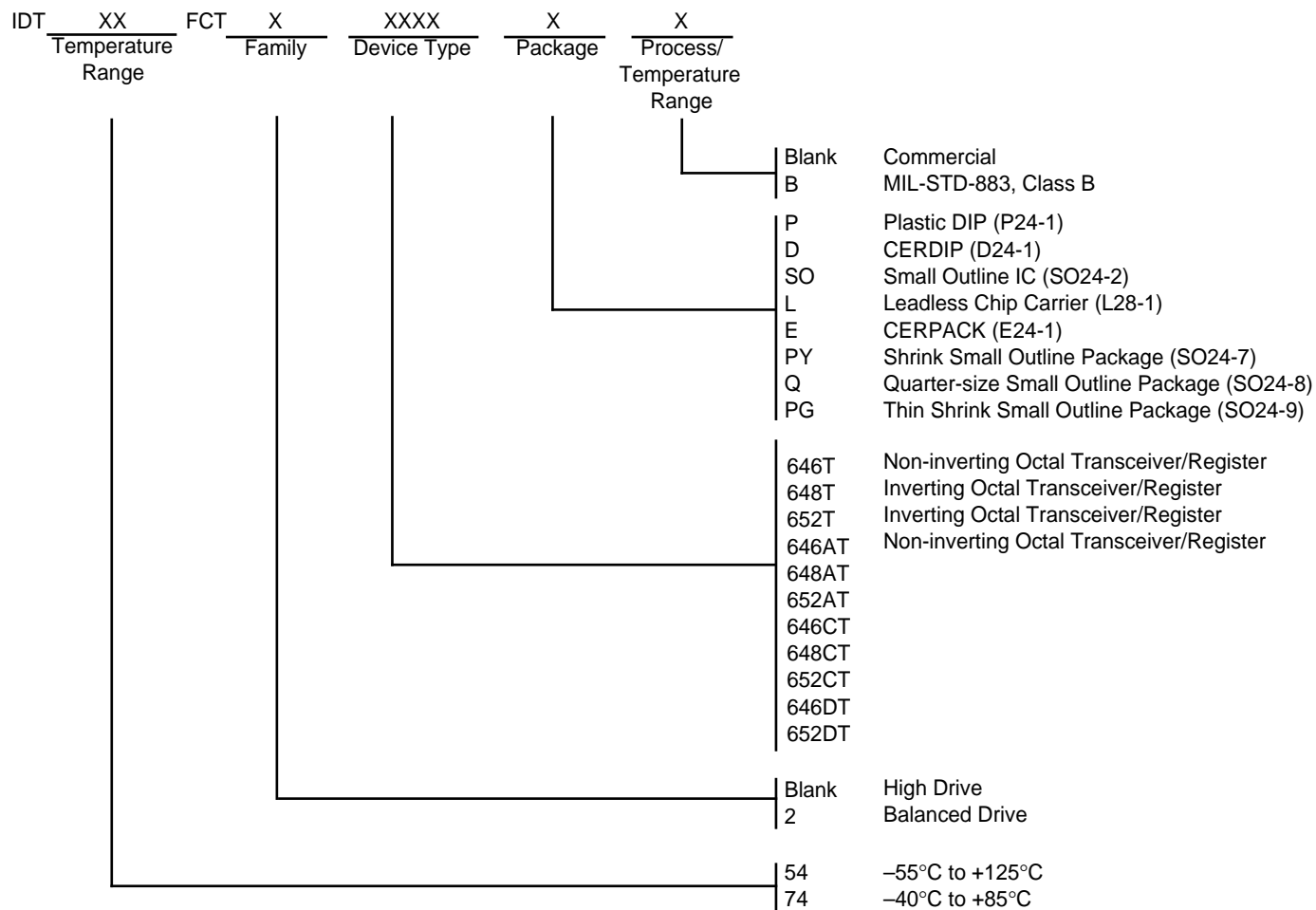

2634 drw 15

This datasheet has been downloaded from:

[www.DatasheetCatalog.com](http://www.DatasheetCatalog.com)

Datasheets for electronic components.



LittleDiode supplies new, hard to find or obsolete electronic components and semiconductors all over the world.

With over two million different components listed you are sure to find the part you need.

Feel free to visit us today at our online store:

[LittleDiode.com](http://LittleDiode.com)

Looking forward to providing you with the best possible service.