



# FAST CMOS OCTAL LATCHED TRANSCEIVER

**IDT54/74FCT543T/AT/CT/DT**

## FEATURES:

- Std., A, C, and D grades
- Low input and output leakage  $\leq 1\mu\text{A}$  (max.)
- CMOS power levels
- True TTL input and output compatibility:
  - $V_{OH} = 3.3V$  (typ.)
  - $V_{OL} = 0.3V$  (typ.)
- High Drive outputs (-15mA IOH, 64mA IOL)
- Meets or exceeds JEDEC standard 18 specifications
- Military product compliant to MIL-STD-883, Class B and DESC listed (dual marked)
- Power off disable outputs permit "live insertion"
- Available in the following packages:
  - Industrial: SOIC, SSOP, QSOP
  - Military: CERDIP, LCC

## DESCRIPTION:

The FCT543T is a non-inverting octal transceiver built using an advanced dual metal CMOS technology. This device contains two sets of eight D-type latches with separate input and output controls for each set. For data flow from A to B, for example, the A-to-B Enable ( $\overline{\text{CEAB}}$ ) input must be low in order to enter data from A0-A7 or to take data from B0-B7, as indicated in the Function Table. With  $\overline{\text{CEAB}}$  low, a low signal on the A-to-B Latch Enable ( $\overline{\text{LEAB}}$ ) input makes the A-to-B latches transparent; a subsequent low-to-high transition of the  $\overline{\text{LEAB}}$  signal puts the A latches in the storage mode and their outputs no longer change with the A inputs. With  $\overline{\text{CEAB}}$  and  $\overline{\text{OEAB}}$  both low, the 3-state B output buffers are active and reflect the data present at the output of the A latches. Control of data from B to A is similar, but uses the  $\overline{\text{CEBA}}$ ,  $\overline{\text{LEBA}}$  and  $\overline{\text{OEBA}}$  inputs.

## FUNCTIONAL BLOCK DIAGRAM

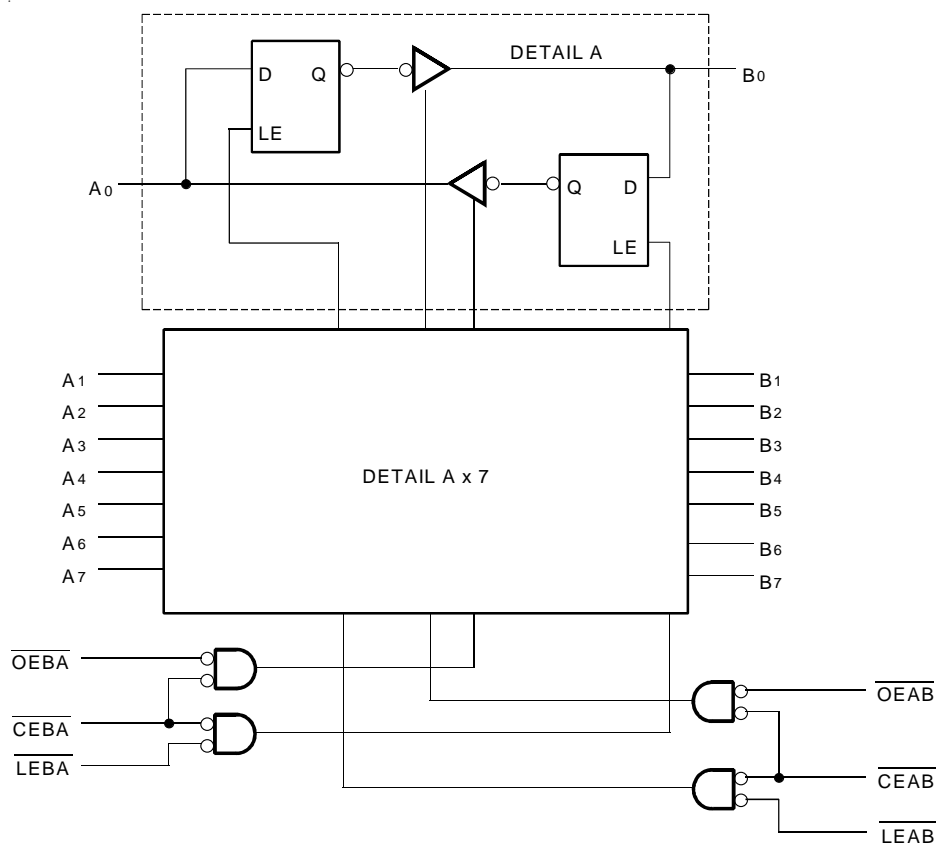

The IDT logo is a registered trademark of Integrated Device Technology, Inc.

MILITARY AND INDUSTRIAL TEMPERATURE RANGES

JUNE 2002

## PIN CONFIGURATION

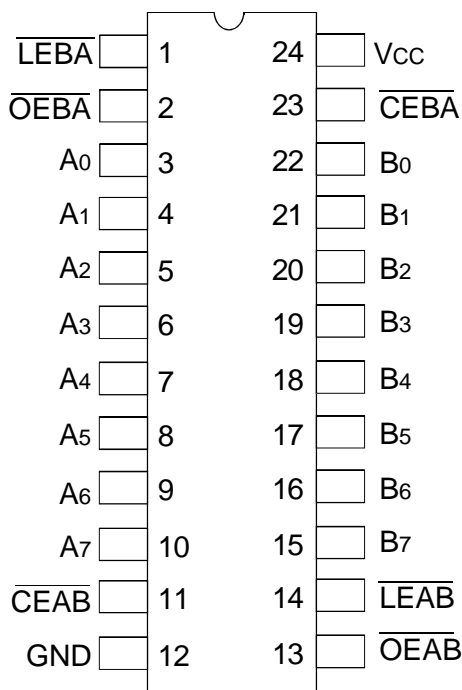

CERDIP/ SOIC/ SSOP/ QSOP  
TOP VIEW

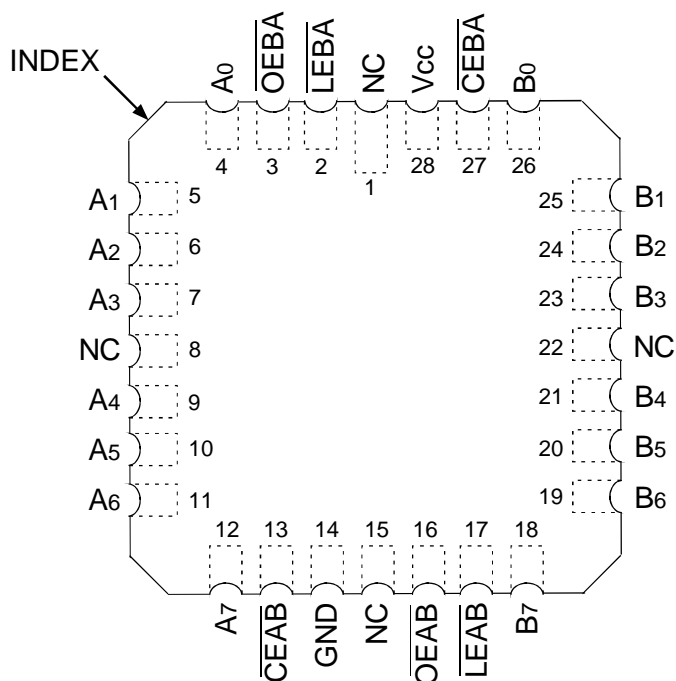

LCC  
TOP VIEW

## ABSOLUTE MAXIMUM RATINGS<sup>(1)</sup>

Symbol	Description	Max	Unit
V <sub>TERM</sub> <sup>(2)</sup>	Terminal Voltage with Respect to GND	-0.5 to +7	V
V <sub>TERM</sub> <sup>(3)</sup>	Terminal Voltage with Respect to GND	-0.5 to V <sub>CC</sub> +0.5	V
T <sub>STG</sub>	Storage Temperature	-65 to +150	°C
I <sub>OUT</sub>	DC Output Current	-60 to +120	mA

### NOTES:

- Stresses greater than those listed under ABSOLUTE MAXIMUM RATINGS may cause permanent damage to the device. This is a stress rating only and functional operation of the device at these or any other conditions above those indicated in the operational sections of this specification is not implied. Exposure to absolute maximum rating conditions for extended periods may affect reliability. No terminal voltage may exceed V<sub>CC</sub> by +0.5V unless otherwise noted.
- Inputs and V<sub>CC</sub> terminals only.
- Output and I/O terminals only.

## PIN DESCRIPTION

Pin Names	Description
$\overline{OEAB}$	A-to-B Output Enable Input (Active LOW)
$\overline{OEBA}$	B-to-A Output Enable Input (Active LOW)
$\overline{CEAB}$	A-to-B Enable Input (Active LOW)
$\overline{CEBA}$	B-to-A Enable Input (Active LOW)
$\overline{LEAB}$	A-to-B Latch Enable Input (Active LOW)
$\overline{LEBA}$	B-to-A Latch Enable Input (Active LOW)
A <sub>0</sub> -A <sub>7</sub>	A-to-B Data Inputs or B-to-A 3-State Outputs
B <sub>0</sub> -B <sub>7</sub>	B-to-A Data Inputs or A-to-B 3-State Outputs

## CAPACITANCE (T<sub>A</sub> = +25°C, F = 1.0MHz)

Symbol	Parameter <sup>(1)</sup>	Conditions	Typ.	Max.	Unit
C <sub>IN</sub>	Input Capacitance	V <sub>IN</sub> = 0V	6	10	pF
C <sub>OUT</sub>	Output Capacitance	V <sub>OUT</sub> = 0V	8	12	pF

### NOTE:

- This parameter is measured at characterization but not tested.

## FUNCTION TABLE<sup>(1, 2)</sup>

For A-to-B (Symmetric with B-to-A)

Inputs			Latch Status	Output Buffers
$\overline{CEAB}$	$\overline{LEAB}$	$\overline{OEAB}$	A-to-B	Bo-B7
H	X	X	Storing	High Z
X	H	X	Storing	X
X	X	H	X	High Z
L	L	L	Transparent	Current A Inputs
L	H	L	Storing	Previous* A Inputs

### NOTES:

- \* Before LEAB LOW-to-HIGH Transition  
H = HIGH Voltage Level  
L = LOW Voltage Level  
X = Don't Care
- A-to-B data flow shown; B-to-A flow control is the same, except using  $\overline{CEBA}$ ,  $\overline{LEBA}$  and  $\overline{OEBA}$ .

## DC ELECTRICAL CHARACTERISTICS OVER OPERATING RANGE

Following Conditions Apply Unless Otherwise Specified:

Industrial:  $T_A = -40^\circ\text{C}$  to  $+85^\circ\text{C}$ ,  $V_{CC} = 5.0\text{V} \pm 5\%$ ; Military:  $T_A = -55^\circ\text{C}$  to  $+125^\circ\text{C}$ ,  $V_{CC} = 5.0\text{V} \pm 10\%$

Symbol	Parameter	Test Conditions <sup>(1)</sup>		Min.	Typ. <sup>(2)</sup>	Max.	Unit
$V_{IH}$	Input HIGH Level	Guaranteed Logic HIGH Level		2	—	—	V
$V_{IL}$	Input LOW Level	Guaranteed Logic LOW Level		—	—	0.8	V
$I_{IH}$	Input HIGH Current <sup>(4)</sup>	$V_{CC} = \text{Max.}$	$V_I = 2.7\text{V}$	—	—	$\pm 1$	$\mu\text{A}$
$I_{IL}$	Input LOW Current <sup>(4)</sup>	$V_{CC} = \text{Max.}$	$V_I = 0.5\text{V}$	—	—	$\pm 1$	$\mu\text{A}$
$I_{OZH}$	High Impedance Output Current (3-State output pins) <sup>(4)</sup>	$V_{CC} = \text{Max.}$	$V_O = 2.7\text{V}$	—	—	$\pm 1$	$\mu\text{A}$
$I_{OZL}$			$V_O = 0.5\text{V}$	—	—	$\pm 1$	
$I_I$	Input HIGH Current <sup>(4)</sup>	$V_{CC} = \text{Max.}, V_I = V_{CC} (\text{Max.})$		—	—	$\pm 1$	$\mu\text{A}$
$V_{IK}$	Clamp Diode Voltage	$V_{CC} = \text{Min.}, I_{IN} = -18\text{mA}$		—	-0.7	-1.2	V
$V_H$	Input Hysteresis	—		—	200	—	mV
$I_{CC}$	Quiescent Power Supply Current	$V_{CC} = \text{Max.}, V_{IN} = \text{GND or } V_{CC}$		—	0.01	1	mA

## OUTPUT DRIVE CHARACTERISTICS

Symbol	Parameter	Test Conditions <sup>(1)</sup>		Min.	Typ. <sup>(2)</sup>	Max.	Unit
$V_{OH}$	Output HIGH Voltage	$V_{CC} = \text{Min.}$ $V_{IN} = V_{IH} \text{ or } V_{IL}$	$I_{OH} = -6\text{mA MIL}$ $I_{OH} = -8\text{mA IND}$	2.4	3.3	—	V
			$I_{OH} = -12\text{mA MIL}$ $I_{OH} = -15\text{mA IND}$	2	3	—	
$V_{OL}$	Output LOW Voltage	$V_{CC} = \text{Min.}$ $V_{IN} = V_{IH} \text{ or } V_{IL}$	$I_{OL} = 48\text{mA MIL}$ $I_{OL} = 64\text{mA IND}$	—	0.3	0.55	V
$I_{OS}$	Short Circuit Current	$V_{CC} = \text{Max.}, V_O = \text{GND}^{(3)}$		-60	-120	-225	mA
$I_{OFF}$	Input/Output Power Off Leakage <sup>(5)</sup>	$V_{CC} = 0\text{V}, V_{IN} \text{ or } V_O \leq 4.5\text{V}$		—	—	$\pm 1$	$\mu\text{A}$

### NOTES:

- For conditions shown as Min. or Max., use appropriate value specified under Electrical Characteristics for the applicable device type.
- Typical values are at  $V_{CC} = 5.0\text{V}$ ,  $+25^\circ\text{C}$  ambient.
- Not more than one output should be tested at one time. Duration of the test should not exceed one second.
- The test limit for this parameter is  $\pm 5\mu\text{A}$  at  $T_A = -55^\circ\text{C}$ .
- This parameter is guaranteed but not tested.

## POWER SUPPLY CHARACTERISTICS

Symbol	Parameter	Test Conditions <sup>(1)</sup>		Min.	Typ. <sup>(2)</sup>	Max.	Unit
$\Delta I_{CC}$	Quiescent Power Supply Current TTL Inputs HIGH	$V_{CC} = \text{Max.}$ $V_{IN} = 3.4V^{(3)}$		—	0.5	2	mA
$I_{CCD}$	Dynamic Power Supply Current <sup>(4)</sup>	$V_{CC} = \text{Max.}$ , Outputs Open $\overline{CEAB}$ and $\overline{OEAB} = \text{GND}$ $\overline{CEBA} = V_{CC}$ One Input Toggling 50% Duty Cycle	$V_{IN} = V_{CC}$ $V_{IN} = \text{GND}$	—	0.15	0.25	mA/ MHz
$I_C$	Total Power Supply Current <sup>(6)</sup>	$V_{CC} = \text{Max.}$ , Outputs Open $f_{CP} = 10\text{MHz}$ ( $\overline{LEAB}$ ) 50% Duty Cycle $\overline{CEAB}$ and $\overline{OEAB} = \text{GND}$ $\overline{CEBA} = V_{CC}$ One Bit Toggling at $f_i = 5\text{MHz}$ 50% duty cycle	$V_{IN} = V_{CC}$ $V_{IN} = \text{GND}$	—	1.5	3.5	mA
			$V_{IN} = 3.4V$ $V_{IN} = \text{GND}$	—	2	5.5	
		$V_{CC} = \text{Max.}$ , Outputs Open $f_{CP} = 10\text{MHz}$ ( $\overline{LEAB}$ ) 50% Duty Cycle $\overline{CEAB}$ and $\overline{OEAB} = \text{GND}$ $\overline{CEBA} = V_{CC}$ Eight Bits Toggling at $f_i = 2.5\text{MHz}$ 50% duty cycle	$V_{IN} = V_{CC}$ $V_{IN} = \text{GND}$	—	3.8	7.3 <sup>(5)</sup>	mA
			$V_{IN} = 3.4V$ $V_{IN} = \text{GND}$	—	6	16.3 <sup>(5)</sup>	

### NOTES:

- For conditions shown as Min. or Max., use appropriate value specified under Electrical Characteristics for the applicable device type.
- Typical values are at  $V_{CC} = 5.0V$ ,  $+25^\circ\text{C}$  ambient.
- Per TTL driven input; ( $V_{IN} = 3.4V$ ). All other inputs at  $V_{CC}$  or  $\text{GND}$ .
- This parameter is not directly testable, but is derived for use in Total Power Supply Calculations.
- Values for these conditions are examples of  $\Delta I_{CC}$  formula. These limits are guaranteed but not tested.
- $I_C = I_{QUIESCENT} + I_{INPUTS} + I_{DYNAMIC}$

$$I_C = I_{CC} + \Delta I_{CC} D_H N_T + I_{CCD} (f_{CP}/2 + f_i N_i)$$

$I_{CC}$  = Quiescent Current

$\Delta I_{CC}$  = Power Supply Current for a TTL High Input ( $V_{IN} = 3.4V$ )

$D_H$  = Duty Cycle for TTL Inputs High

$N_T$  = Number of TTL Inputs at  $D_H$

$I_{CCD}$  = Dynamic Current caused by an Input Transition Pair (HLH or LHL)

$f_{CP}$  = Clock Frequency for Register Devices (Zero for Non-Register Devices)

$f_i$  = Output Frequency

$N_i$  = Number of Outputs at  $f_i$

All currents are in milliamps and all frequencies are in megahertz.

SWITCHING CHARACTERISTICS OVER OPERATING RANGE - INDUSTRIAL

Symbol	Parameter	Condition <sup>(1)</sup>	74FCT543AT		74FCT543CT		74FCT543DT		Unit
			Min. <sup>(2)</sup>	Max.	Min. <sup>(2)</sup>	Max.	Min. <sup>(2)</sup>	Max.	
t <sub>PLH</sub> t <sub>PHL</sub>	Propagation Delay Transparent Mode Ax to Bx or Bx to Ax	CL = 50pF RL = 500Ω	1.5	6.5	1.5	5.3	1.5	4.4	ns
t <sub>PLH</sub> t <sub>PHL</sub>	Propagation Delay $\overline{LEBA}$ to Ax, $\overline{LEAB}$ to Bx		1.5	8	1.5	7	1.5	5	ns
t <sub>PZH</sub> t <sub>PZL</sub>	Output Enable Time $\overline{OEBA}$ or $\overline{OEAB}$ to Ax or Bx $\overline{CEBA}$ or $\overline{CEAB}$ to Ax or Bx		1.5	9	1.5	8	1.5	5.4	ns
t <sub>PHZ</sub> t <sub>PLZ</sub>	Output Disable Time $\overline{OEBA}$ or $\overline{OEAB}$ to Ax or Bx $\overline{CEBA}$ or $\overline{CEAB}$ to Ax or Bx		1.5	7.5	1.5	6.5	1.5	4.3	ns
t <sub>SU</sub>	Set-up Time, HIGH or LOW Ax or Bx to $\overline{LEBA}$ or $\overline{LEAB}$		2	—	2	—	1.5	—	ns
t <sub>H</sub>	Hold Time, HIGH or LOW Ax or Bx to $\overline{LEBA}$ or $\overline{LEAB}$		2	—	2	—	1.5	—	ns
t <sub>w</sub>	$\overline{LEBA}$ or $\overline{LEAB}$ Pulse Width LOW		5	—	5	—	3 <sup>(3)</sup>	—	ns

SWITCHING CHARACTERISTICS OVER OPERATING RANGE - MILITARY

Symbol	Parameter	Condition <sup>(1)</sup>	54FCT543T		54FCT543AT		54FCT543CT		Unit
			Min. <sup>(2)</sup>	Max.	Min. <sup>(2)</sup>	Max.	Min. <sup>(2)</sup>	Max.	
t <sub>PLH</sub> t <sub>PHL</sub>	Propagation Delay Transparent Mode Ax to Bx or Bx to Ax	CL = 50pF RL = 500Ω	1.5	10	1.5	7.5	1.5	6.1	ns
t <sub>PLH</sub> t <sub>PHL</sub>	Propagation Delay $\overline{LEBA}$ to Ax, $\overline{LEAB}$ to Bx		1.5	14	1.5	9	1.5	8	ns
t <sub>PZH</sub> t <sub>PZL</sub>	Output Enable Time $\overline{OEBA}$ or $\overline{OEAB}$ to Ax or Bx $\overline{CEBA}$ or $\overline{CEAB}$ to Ax or Bx		1.5	14	1.5	10	1.5	9	ns
t <sub>PHZ</sub> t <sub>PLZ</sub>	Output Disable Time $\overline{OEBA}$ or $\overline{OEAB}$ to Ax or Bx $\overline{CEBA}$ or $\overline{CEAB}$ to Ax or Bx		1.5	13	1.5	8.5	1.5	7.5	ns
t <sub>SU</sub>	Set-up Time, HIGH or LOW Ax or Bx to $\overline{LEBA}$ or $\overline{LEAB}$		3	—	2	—	2	—	ns
t <sub>H</sub>	Hold Time, HIGH or LOW Ax or Bx to $\overline{LEBA}$ or $\overline{LEAB}$		2	—	2	—	2	—	ns
t <sub>w</sub>	$\overline{LEBA}$ or $\overline{LEAB}$ Pulse Width LOW		5	—	5	—	5	—	ns

NOTES:

1. See test circuit and waveforms.
2. Minimum limits are guaranteed but not tested on Propagation Delays.
3. This limit is guaranteed but not tested.

TEST CIRCUITS AND WAVEFORMS

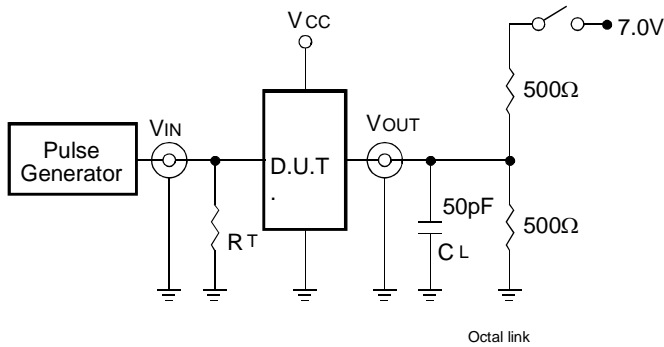

Test Circuits for All Outputs

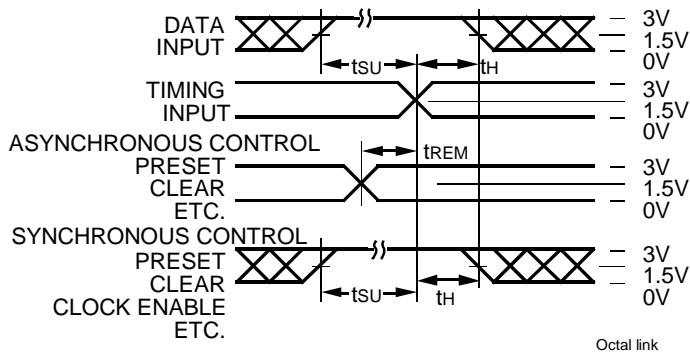

Set-Up, Hold, and Release Times

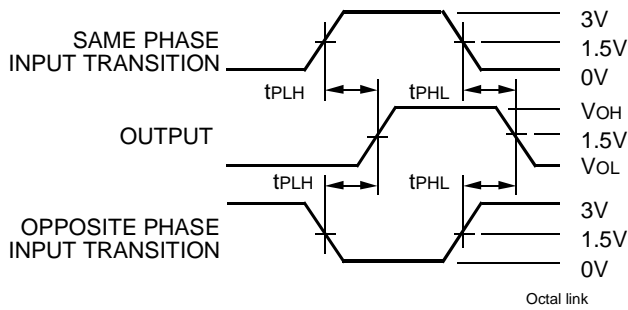

Propagation Delay

SWITCH POSITION

Test	Switch
Open Drain Disable Low Enable Low	Closed
All Other Tests	Open

DEFINITIONS:

CL = Load capacitance: includes jig and probe capacitance.  
RT = Termination resistance: should be equal to ZOUT of the Pulse Generator.

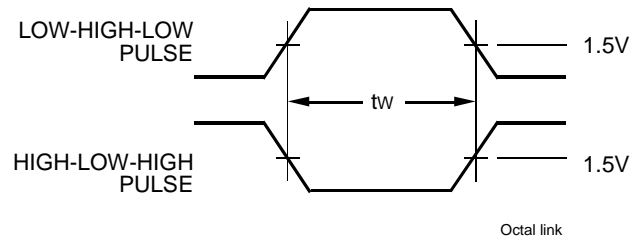

Pulse Width

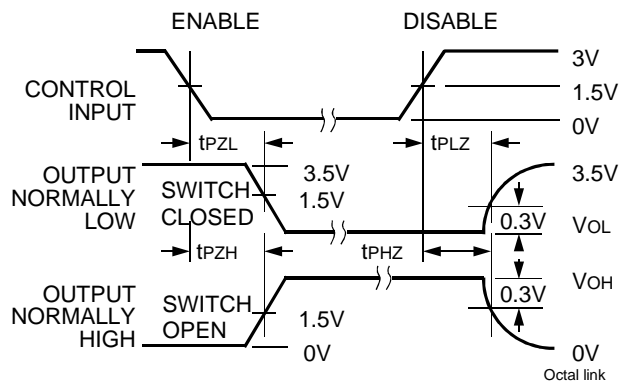

Enable and Disable Times

NOTES:

1. Diagram shown for input Control Enable-LOW and input Control Disable-HIGH.
2. Pulse Generator for All Pulses: Rate ≤ 1.0MHz; tr ≤ 2.5ns; tr ≤ 2.5ns.

ORDERING INFORMATION

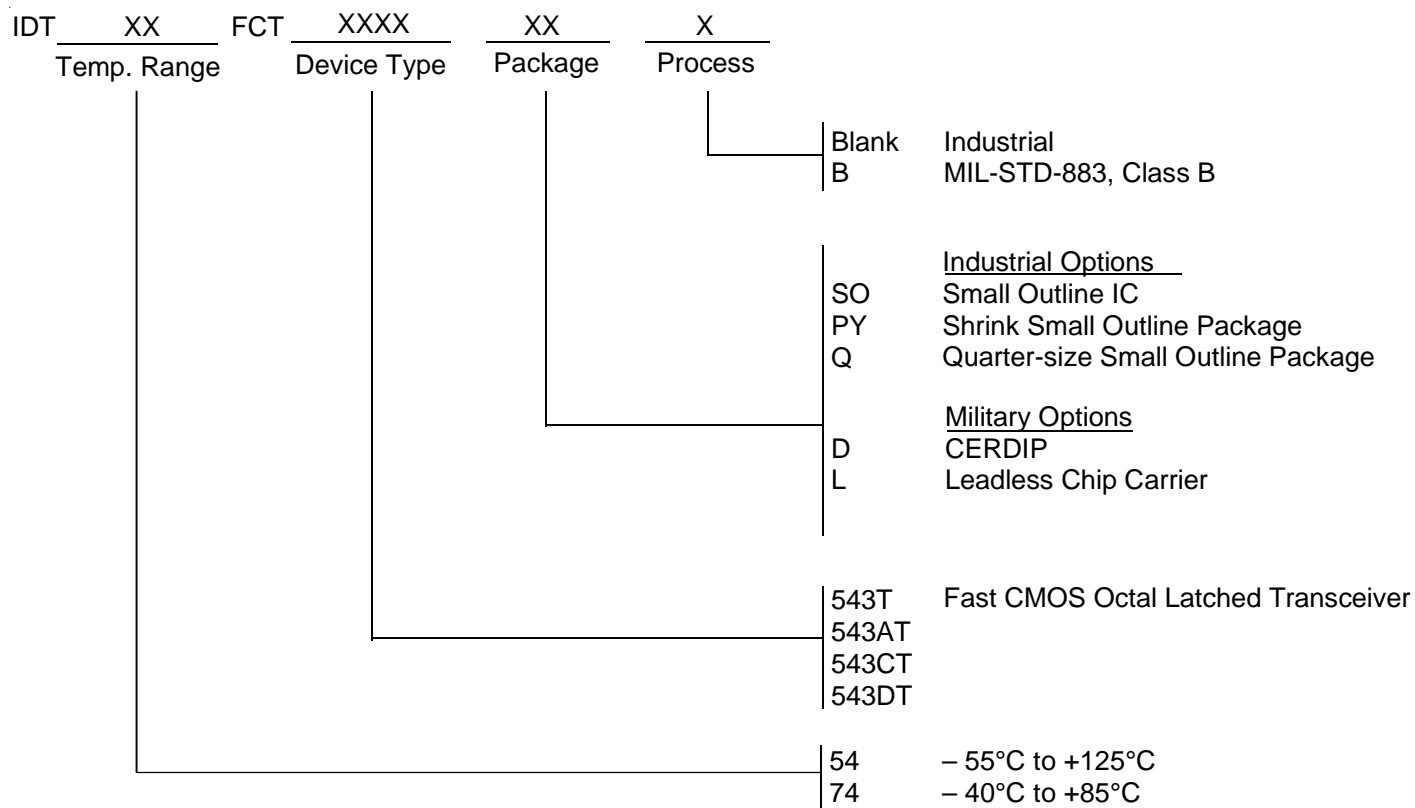

DATA SHEET DOCUMENT HISTORY

6/24/2002 Updated as per PDNs Logic-00-07 and Logic-01-04



**CORPORATE HEADQUARTERS**  
2975 Stender Way  
Santa Clara, CA 95054

**for SALES:**  
800-345-7015 or 408-727-6116  
fax: 408-492-8674  
www.idt.com

**for Tech Support:**  
logichelp@idt.com  
(408) 654-6459



LittleDiode supplies new, hard to find or obsolete electronic components and semiconductors all over the world.

With over two million different components listed you are sure to find the part you need.

Feel free to visit us today at our online store:

[LittleDiode.com](http://LittleDiode.com)

Looking forward to providing you with the best possible service.