

CLC533 High-Speed 4:1 Analog Multiplexer

General Description

The CLC533 is a high-speed 4:1 multiplexer employing active input and output stages. The CLC533 also employs a closed-loop design which dramatically improves accuracy over conventional analog multiplexer circuits. This monolithic device is constructed using an advanced high-performance bipolar process.

The CLC533 has been specifically designed to provide a 24ns settling time to 0.01%. This coupled with the adjustable bandwidth, makes the CLC533 an ideal choice for infrared and CCD imaging systems, with channel-to-channel isolation of 80dB @ 10MHz. Low distortion and spurious signal levels (-80dBc) make the CLC533 a very suitable choice for I/Q processors in radar receivers.

The CLC533 is offered over both the industrial and military temperature ranges. The industrial versions, CLC533AJP/AJE/AIB, are specified from -40°C to +85°C and are packaged in 16-pin plastic DIPs, SOIC's and CERDIP packages. The extended temperature versions, CLC533A8B/A8L-2A, are specified from -55°C to +125°C and are packaged in 16-pin CERDIP and 20-terminal LCC packages.

Ordering Information ...

| | | |
|--------------|-----------------|---------------------------------|
| CLC533AJP | -40°C to +85°C | 16-pin plastic DIP |
| CLC533AJE | -40°C to +85°C | 16-pin plastic SOIC |
| CLC533ALC | -40°C to +85°C | dice |
| CLC533A8B | -55°C to +125°C | 16-pin CERDIP, MIL-STD-883 |
| CLC533AMC | -40°C to +85°C | dice, MIL-STD-833 |
| CLC533A8L-2A | -55°C to +125°C | 20-terminal LCC, MIL-STD-883 |

Contact factory for other packages and DESC SMD number.

Features

- 12-bit settling (0.01%) – 17ns
- Low noise – 42μVrms
- Isolation – 80dB @ 10MHz
- 110MHz -3dB bandwidth ($A_v = +2$)
- Low distortion – 80dB @ 5MHz
- Adjustable bandwidth – 180MHz (max)

Applications

- Infrared system multiplexing
- CCD sensor signals
- Radar I/Q switching
- High definition video HDTV
- Test and calibration

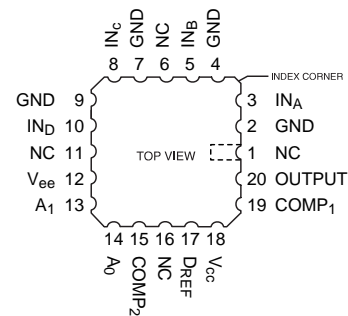
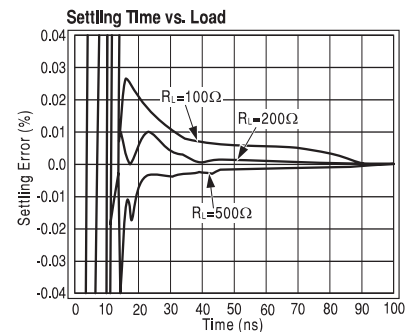

Functional Diagram

| A ₁ | A ₀ | OUT |
|----------------|----------------|-----|
| 0 | 0 | A |
| 0 | 1 | B |
| 1 | 0 | C |
| 1 | 1 | D |

ECL Mode - D_{REF} = open
TTL Mode - D_{REF} = +5V

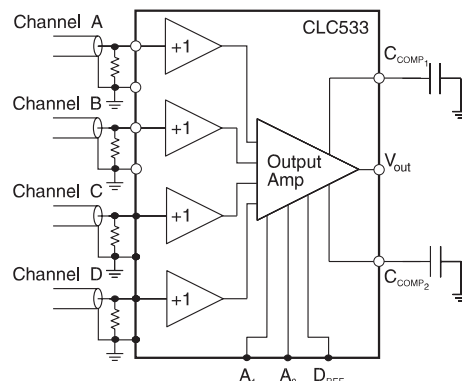

Pinout DIP & SOIC

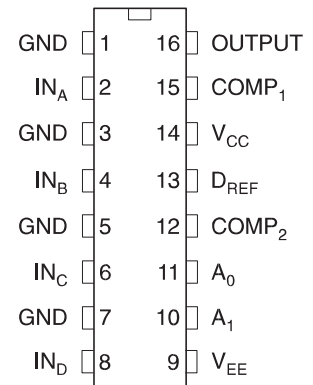

CLC533 Electrical Characteristics (+V_{CC} = +5.0V; -V_{EE} = -5.2V; R_{in} = 50Ω; R_L = 500Ω; C_{COMP} = 8pf; ECL Mode, pin 13 = NC)

| PARAMETERS | | CONDITIONS | TYP | MIN/MAX RATINGS ² | | | | UNITS | SYMBOL |
|---|------------------|---------------------------------------|-------|------------------------------|-------|-------|--------|-------|--------|
| Ambient Temperature | | CLC533AJP/AJE/AIB | +25°C | -40°C | +25°C | +85°C | | | |
| FREQUENCY DOMAIN RESPONSE | | | | | | | | | |
| -3dB bandwidth | | V _{OUT} < 0.1V _{pp} | 180 | 130 | 130 | 110 | MHz | SSBW | |
| -3dB bandwidth | | V _{OUT} = 2V _{pp} | 45 | 35 | 35 | 30 | MHz | LSBW | |
| gain flatness | | V _{OUT} < 0.1V _{pp} | | | | | | | |
| peaking | | 0.1MHz to 200MHz | 0.2 | 0.5 | 0.5 | 0.5 | dB | GFP | |
| rolloff | | 0.1MHz to 100MHz | 1.0 | 2.0 | 2.0 | 3.0 | dB | GFR | |
| linear phase deviation | | dc to 100MHz | 2.0 | | | | deg | LPD | |
| crosstalk rejection - 1 channel | | 2V _{pp} , 10MHz | 80 | 74 | 74 | 74 | dB | CT10 | |
| | | 2V _{pp} , 20MHz | 74 | 68 | 68 | 68 | dB | CT20 | |
| | | 2V _{pp} , 30MHz | 68 | 62 | 62 | 62 | dB | CT30 | |
| crosstalk rejection - 3 channels | | 2V _{pp} , 10MHz | 80 | 74 | 74 | 74 | dB | 3CT10 | |
| | | 2V _{pp} , 20MHz | 74 | 68 | 68 | 68 | dB | 3CT20 | |
| | | 2V _{pp} , 30MHz | 68 | 62 | 62 | 62 | dB | 3CT30 | |
| TIME DOMAIN PERFORMANCE | | | | | | | | | |
| rise and fall time | | 0.5V step | 2.7 | 3.3 | 3.3 | 3.8 | ns | TRS | |
| | | 2V step | 10 | 12.5 | 12.5 | 14.5 | ns | TRL | |
| settling time ² | 2V step | ±0.01% | 17 | 24 | 24 | 27 | ns | TSP | |
| | | ±0.1% | 13 | 18 | 18 | 21 | ns | TSS | |
| overshoot | | 2.0V step | 2 | 5 | 5 | 6 | % | OS | |
| slew rate | | | 160 | 130 | 130 | 110 | V/μs | SR | |
| SWITCH PERFORMANCE | | | | | | | | | |
| channel to channel switching time | | 50% SELECT to 10%V _{OUT} | 6 | 8 | 8 | 9 | ns | SWT10 | |
| (2V step at output) | | 50% SELECT to 90%V _{OUT} | 16 | 21 | 21 | 24 | ns | SWT90 | |
| switching transient | | | 30 | | | | mV | ST | |
| DISTORTION AND NOISE PERFORMANCE | | | | | | | | | |
| 2nd harmonic distortion | | 2V _{pp} , 5MHz | 80 | 67 | 67 | 67 | dBc | HD2 | |
| 3rd harmonic distortion | | 2V _{pp} , 5MHz | 86 | 67 | 67 | 67 | dBc | HD3 | |
| equivalent input noise | | | | | | | | | |
| spot noise voltage | | > 1MHz | 4.2 | | | | nV/√Hz | SNF | |
| integrated noise | | 1MHz to 100MHz | 42 | 54 | | 51 | mVrms | INV | |
| spot noise current | | | 5 | | | | pA/√Hz | SNF | |
| STATIC AND DC PERFORMANCE | | | | | | | | | |
| * analog output offset | | | 1 | 12 | 3.5 | 4.5 | mV | VOS | |
| temperature coefficient | | | 15 | 90 | | 20 | μV/°C | DVIO | |
| * analog input bias current | | | 50 | 280 | 120 | 120 | μA | IBN | |
| temperature coefficient | | | 0.3 | 2.0 | | 0.8 | μA/°C | DIBN | |
| analog input resistance | | | 200 | 90 | 120 | 120 | kΩ | RIN | |
| analog input capacitance | | | 2 | 3.0 | 2.5 | 2.5 | pF | CIN | |
| * gain accuracy | ±2V | | 0.994 | 0.988 | 0.988 | 0.988 | V/V | GA | |
| integral endpoint linearity | ±1V (full scale) | | 0.02 | 0.05 | 0.03 | 0.03 | %FS | ILIN | |
| output voltage | no load | | ±3.4 | 2.4 | 2.8 | 2.8 | V | VO | |
| output current | | | 45 | 20 | 50 | 50 | mA | IO | |
| output resistance | DC | | 1.5 | 4.0 | 2.5 | 2.5 | Ω | RO | |
| DIGITAL INPUT PERFORMANCE | | | | | | | | | |
| ECL mode (D _{REF} floating) | | | | | | | | | |
| input voltage logic HIGH | | | | -1.1 | -1.1 | -1.1 | V | VIH1 | |
| input voltage logic LOW | | | | -1.5 | -1.5 | -1.5 | V | VIL1 | |
| input current logic HIGH | | | 200 | 220 | 80 | 80 | μA | IIH1 | |
| input current logic LOW | | | 200 | 220 | 80 | 80 | μA | IIL1 | |
| TTL mode (D _{REF} = +5V) | | | | | | | | | |
| input voltage logic HIGH | | | | 2.0 | 2.0 | 2.0 | V | VIH2 | |
| input voltage logic LOW | | | | 0.8 | 0.8 | 0.8 | V | VIL2 | |
| input current logic HIGH | | | 200 | 220 | 80 | 80 | μA | IIH2 | |
| input current logic LOW | | | 200 | 220 | 80 | 80 | μA | IIL2 | |
| POWER REQUIREMENTS | | | | | | | | | |
| * supply current (+V _{CC} = +5.0V) | no load | | 28 | 38 | 36 | 36 | mA | ICC | |
| * supply current (-V _{EE} = -5.2V) | no load | | 28.5 | 39 | 37 | 37 | mA | IEE | |
| nominal power dissipation | no load | | 288 | | | | mW | PD | |
| * power supply rejection ratio | | | | -53 | -60 | -60 | dB | PSRR | |

Min/max ratings are based on product characterization and simulation. Individual parameters are tested as noted. Outgoing quality levels are determined from tested parameters.

CLC533 Typical Performance Characteristics ($T_A = 25^\circ\text{C}$, $+V_{CC} = +5\text{V}$, $-V_{EE} = -5.2\text{V}$, $R_L = 500\Omega$ unless specified)

Small-Signal Gain & Phase vs. Load

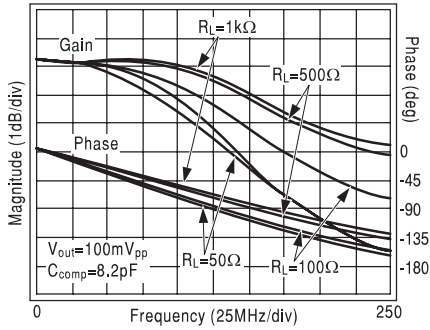

Recommended Compensation Cap vs. Load

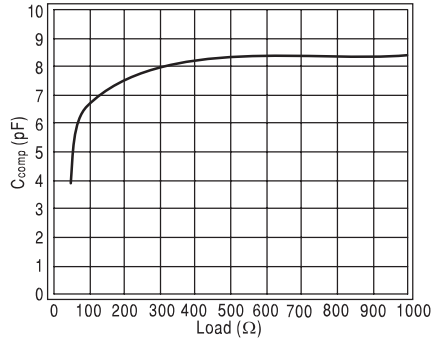

Small Signal Gain/Phase vs. Load*

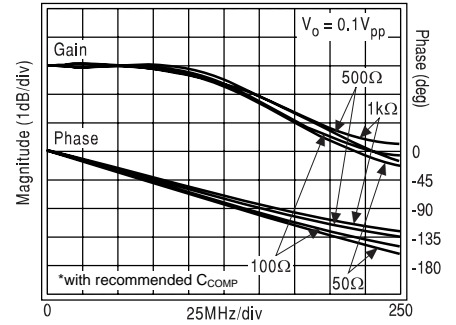

Large-Signal Frequency Response vs. Load

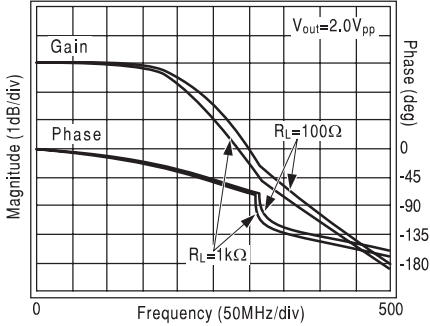

CLC533 Switch Mode Distortion

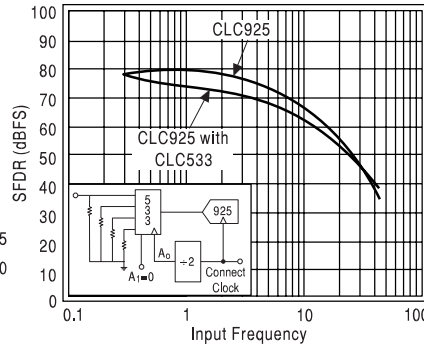

Output Impedance

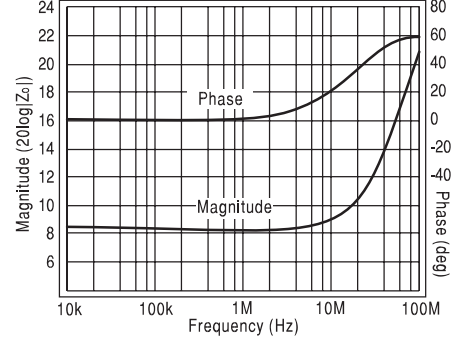

Channel-to-Channel Crosstalk

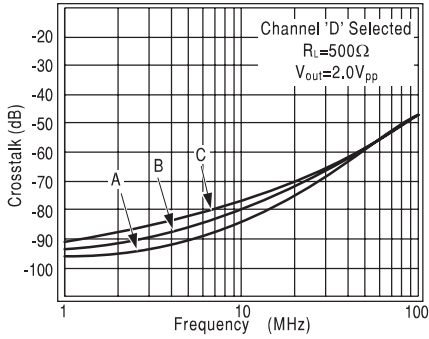

All Hostile Channel-to-Channel Crosstalk

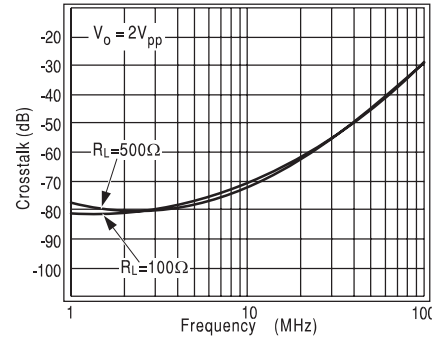

Digitalized Pulse Response

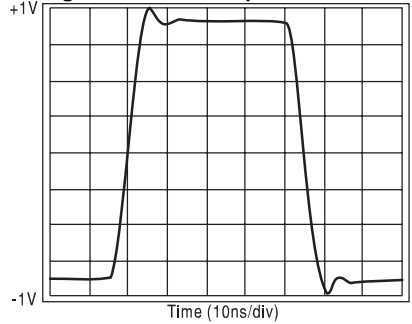

Small-Signal Pulse Response

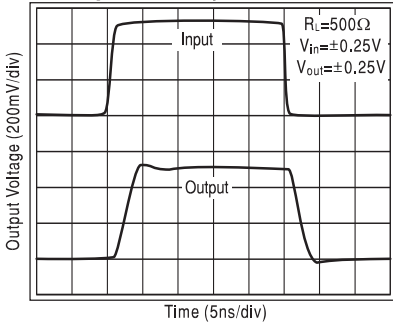

Large-Signal Pulse Response vs. C_{comp}

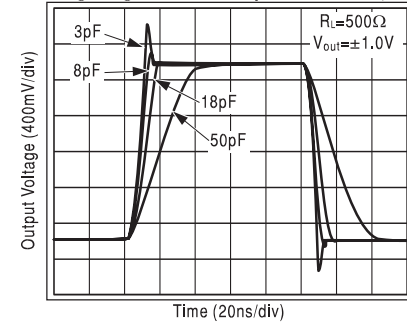

Large-Signal Pulse Response vs. Load

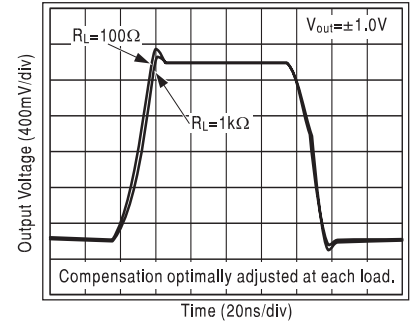

Switched Pulse Response vs. C_{comp}

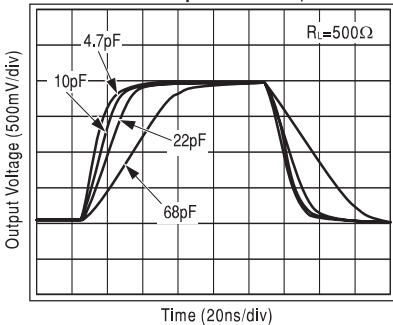

Settling Time vs. C_{comp}

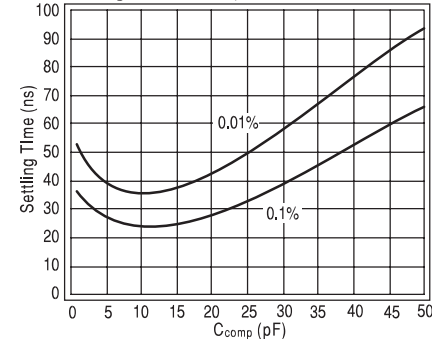

Settling Time vs. Load

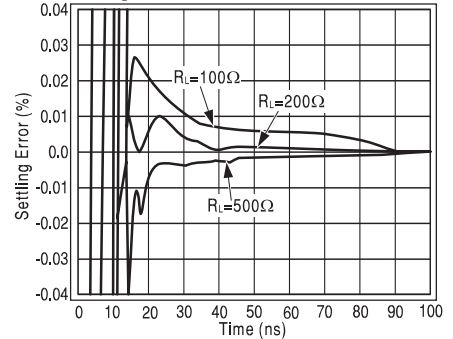

CLC533 Typical Performance Characteristics ($T_A = 25^\circ\text{C}$, $+V_{CC} = +5\text{V}$, $-V_{EE} = -5.2\text{V}$, $R_L = 500\Omega$ unless specified)

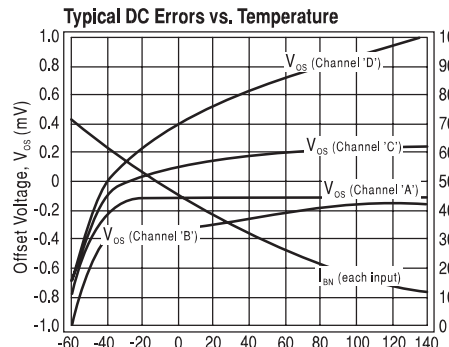
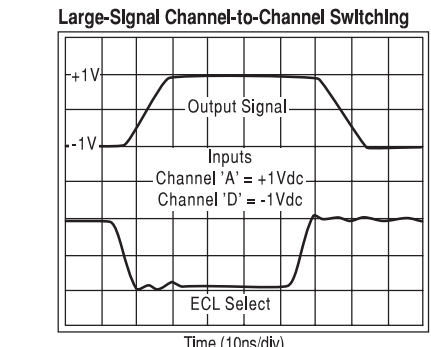
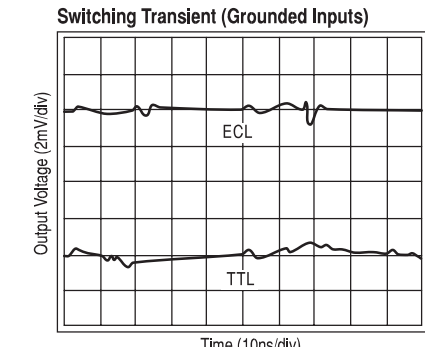
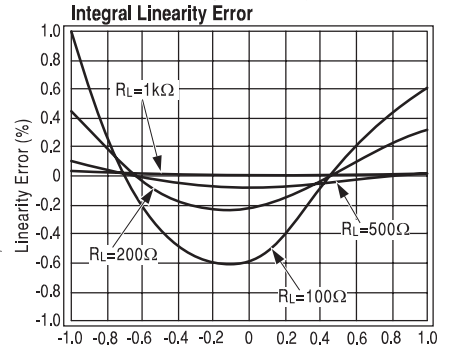
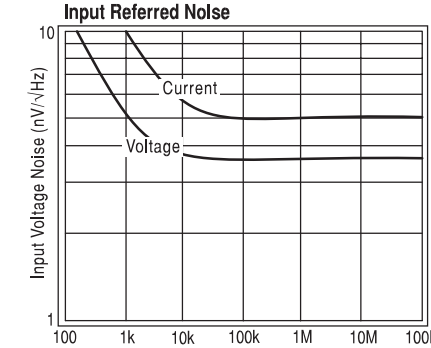
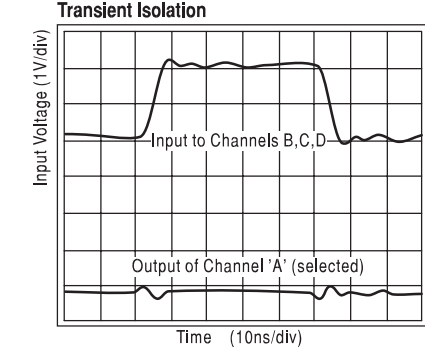
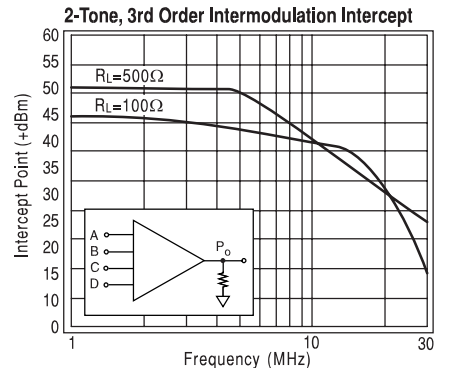
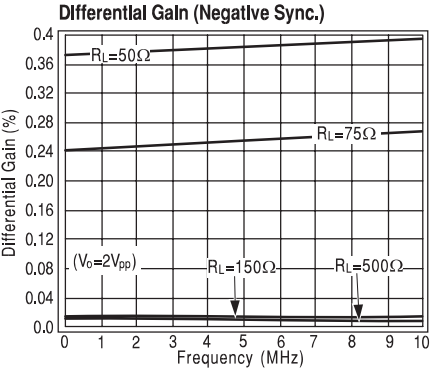
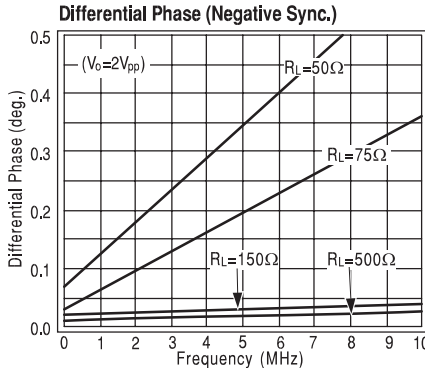
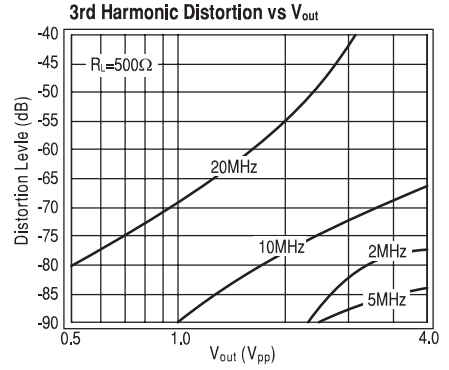
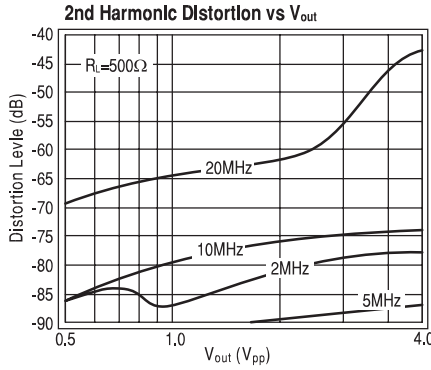
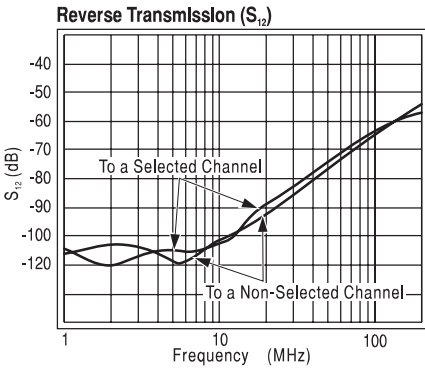
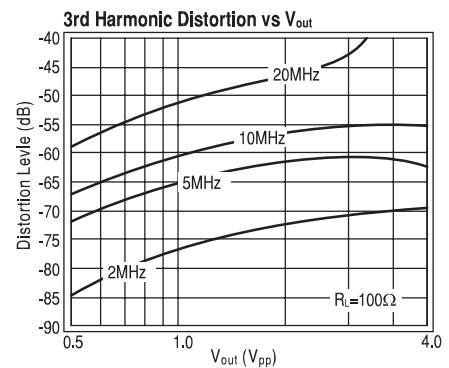
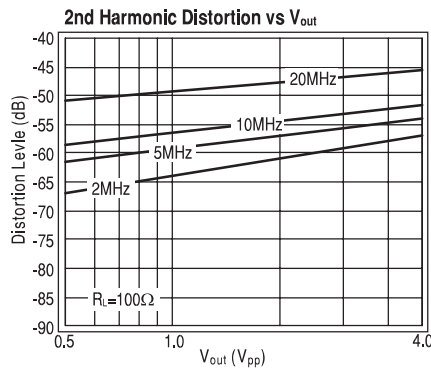
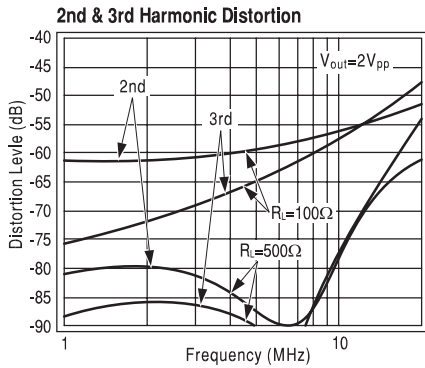

Recommended Operating Conditions

| | |
|---|--------------|
| positive supply voltage (+V _{CC}) | +5.0V |
| negative supply voltage (-V _{EE}) | -5.2V |
| differential voltage between any two GND's | 10mV |
| analog input voltage range | ±2V |
| A _X input voltage range (TTL mode) | 0V to +5.0V |
| A _X input voltage range (ECL mode) | 0V to -2.0V |
| C _{COMP} range | 5pF to 100pF |

| thermal data | θ _{JC} (°C/W) | θ _{JA} (°C/W) |
|--------------------|------------------------|------------------------|
| 16-pin plastic | 50 | 60 |
| 16-pin Cerdip | 20 | 65 |
| 16-pin SOIC | 60 | 75 |
| 20-terminal LCC | 20 | 35 |
| 16-pin side brazed | 20 | 50 |

Note 1: Test levels are as follows:

* AJ : 100% tested at +25°C.

Note 2: Settling time measured from the 50% analog output transition.

Note 3: Absolute maximum ratings are limiting values, to be applied individually, and beyond which the serviceability of the circuit may be impaired.

Reliability Information

Transistor count 144

Absolute Maximum Ratings³

| | |
|--|--------------------------------------|
| positive supply voltage (+V _{CC}) | -0.5V to +7.0V |
| negative supply voltage (-V _{EE}) | +0.5V to -7.0V |
| differential voltage between any two GND's | 200mV |
| analog input voltage range | -V _{EE} to +V _{CC} |
| digital input voltage range | -V _{EE} to +V _{CC} |
| output short circuit duration (shorted to GND) | Infinite |
| junction temperature | +150°C |
| operating temperature range | |
| CLC533AJP/AJE/AIB | -40°C to +85°C |
| storage temperature range | -65°C to +150°C |
| lead solder duration (+300°C) | 10 sec |
| ESD rating (human body model) | <500V |

Functional operability under any of these conditions is not necessarily implied. Exposure to maximum ratings for extended periods may affect device reliability.

Package Thermal Resistance

| Package | θ _{JC} | θ _{JA} |
|---------|-----------------|-----------------|
| AJP | 45°C/W | 95°C/W |
| AJE | 35°C/W | 100°C/W |
| CERDIP | 25°C/W | 65°C/W |

System Timing Diagram

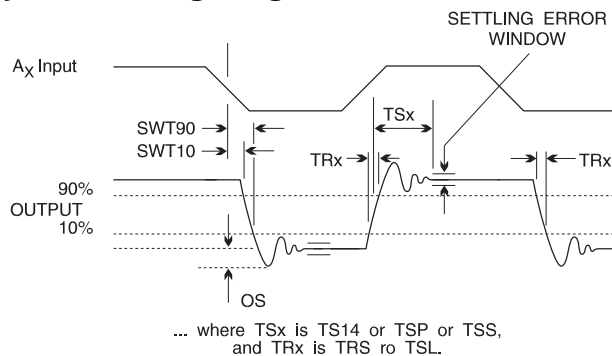

Switching Transient Timing Diagram

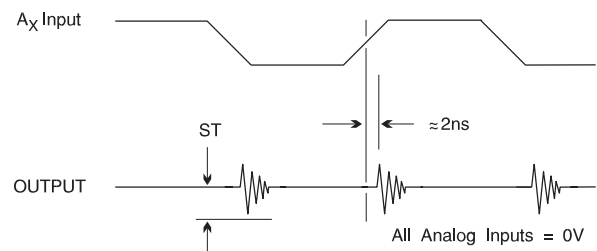

APPLICATIONS INFORMATION

Operation

The CLC533 is a 4:1 analog multiplexer designed with a closed loop architecture to provide very low harmonic distortion and superior channel to channel isolation. This low distortion, coupled with very fast switching speed make the CLC533 an ideal multiplexer for data conversion applications. User selectable ECL or TTL select logic adds to the versatility of this device. External frequency response compensation allows the performance of the CLC533 to be optimized for each application.

Digital Interface and Channel Select

The CLC533 has two channel select pins which can be used to select any one of the four inputs. These digital inputs can be configured to meet TTL, ECL or CMOS logic levels with the D_{REF} pin. If D_{REF} is left

open, then the A₀ and A₁ select inputs will respond to ECL 10K switching levels (Figure 1). For TTL or CMOS levels, D_{REF} should be tied to V_{CC} (Figure 2). There is an internal series resistor which makes it possible to connect D_{REF} directly to the power supply. Select pins according to the truth table shown on the front page. A more positive voltage is considered to be a logic '1'. Therefore with no connection to A₀ or A₁ the internal pull-up resistors will select the D input to be passed through to the output.

Compensation

The CLC533 is externally compensated, allowing the user to select the bandwidth that best suits the application. Decreasing bandwidth has two advantages: lower noise and lower switching transients. In a sampled system, noise at frequencies

above 1/2 the sampling frequency will be aliased into the baseband and will corrupt the signal of interest. When the CLC533 is switched from one channel to another, the output slews rapidly until it arrives at the new signal. This high slew rate signal can capacitively couple into other nodes in the circuit and can have a detrimental effect on overall performance. Since coupling through stray capacitance and inductances decreases with decreasing dV/dt , the slew rate should be minimized consistent with system throughput requirements.

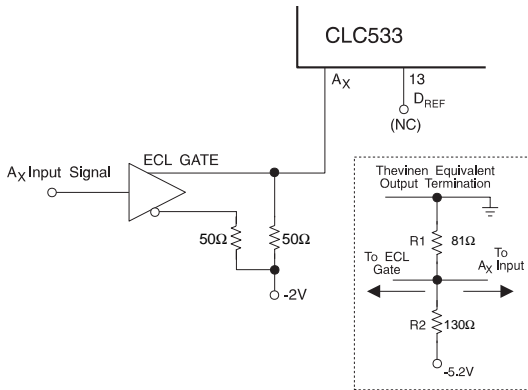

Figure 1: ECL Level Channel SELECT Configuration

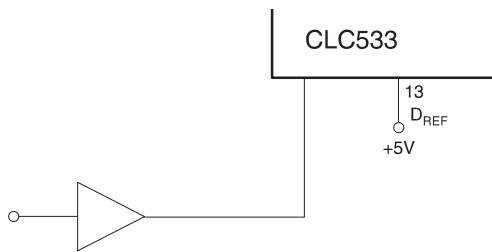

Figure 2: TTL/CMOS Level Channel SELECT Configuration

Output Load

The final frequency response that is realized is a result of both the compensation capacitor and the load that the CLC533 is driving. Figure 3 below shows the effect that C_{COMP} has on bandwidth for a fixed load. Graphs on the preceding pages demonstrate the effect of C_{COMP} on pulse response and settling time, and the optimum value of C_{COMP} to maximize bandwidth for various amounts of resistive loading. Because there are so many factors that go into determining the optimum value of C_{COMP} it is recommended that once a value is selected, the application circuit be built up and larger and smaller compensation capacitors be tried to determine the best value for that particular circuit.

The output load that the CLC533 is driving has an effect on the harmonic distortion of the device as well as frequency response. Distortion is minimized with a 500Ω load. When driving components with a high input impedance, addition of a load resistor can improve the performance. If the load is capacitive in nature, it should

be isolated from the CLC533 output via a series resistor. The recommended series resistor R_S , for various capacitive loads C_L , can be found by referring to the “Recommended Compensation Cap vs. Load” plot in the “Typical Performance” section.

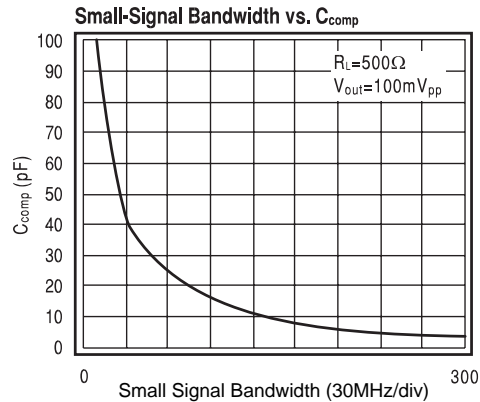

Figure 3

Power Supplies and Grounding

In any circuit there are connections between components that are not desired. Some of the most common of these are the connections made through the power supply and grounding network. The goal in laying out the power and ground network for a mixed mode circuit is to minimize the impedance from the power pins to the supply, and minimize the impedance of the ground network.

To minimize impedance of the ground and power nets, use the heaviest possible traces and ground planes for minimizing the DC impedance. To further reduce the supply impedance at higher frequencies, a 6 to 10μF capacitor should be placed between supply lines and ground. At very high frequencies, the inductance in the traces becomes significant and 0.01 to 0.1μF bypass capacitors need to be placed as close to each power pin as is practical. To reduce the negative effects of ground impedances that will exist, consider the paths that ground currents must take to get from the various devices on the circuit card to the power supply. To achieve good system performance, it is vital that large currents and high-speed time varying currents like CMOS signals, be kept away from precision analog components. This can be achieved through layout of the power and ground nets. Using a ground plane split between analog and digital sections of the circuit forces all of the ground current from the digital circuits to go directly to the power connector without straying to the analog side of the card.

Optimizing for Channel-to-Channel Isolation

Although the CLC533 has excellent channel-to-channel isolation, if there is cross talk between the input signals before they reach the CLC533, the multiplexer will faithfully pass these corrupted signals through to its output and dutifully take the blame for poor

isolation. The CLC533 evaluation board has successfully demonstrated in excess of 80dB of isolation and can be considered to be a model for the layout of boards requiring good isolation. The evaluation board has input signal traces shielded by a guard ring as shown in Figure 4. These guard rings help to prevent ground return currents from other channels finding their way into the selected channel. If there are input termination resistors, care must be taken that the ground return currents between resistors cannot interfere with each other. Use of chip resistors allows for best isolation, and if the guard ring around the input trace is used for the termination resistor ground, then the ground currents for each input are forced to take paths away from one another.

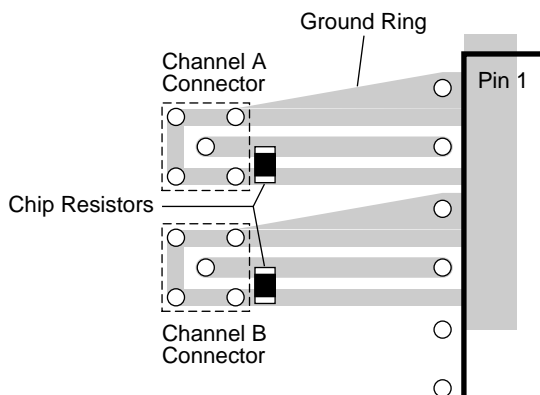

Figure 4: Analog Input Using Guard Ring

Use of the CLC533 with an Analog-to-Digital Converter

To get the most out of the combination of multiplexer and ADC, a clear understanding of both converter operation and multiplexer operation is required. Careful attention to the timing of the convert signal to the ADC and the channel select signal to the CLC533 is one key to optimizing performance.

To obtain the best performance from the combination, the output of the CLC533 must be a valid representation of the selected input at the time that the ADC samples it. The time at which the ADC samples the input is determined by the type of ADC that is being used. Subranging ADCs usually have a Track-and-Hold (T/H) at their input. For a successful combination of the multiplexer and the ADC, the multiplexer timing and the T/H timing must be compatible. When the ADC is given a convert command, the T/H transitions from Track mode to Hold mode. The delay between the convert command and this transition is usually specified as Aperture Delay or as Sampling Time Offset. To maximize the time that the multiplexer has to settle and the T/H has to acquire the signal, the multiplexer should begin its transition from one input to the other immediately after the T/H transition has taken place. However it is during this period of time that a subranging ADC is performing analog processing of the sampled signal, and high slew rate transitions on the

input may feed through to the sample being converted. To minimize this interaction there are two strategies that can be taken: strategy one applies when the sample rate of the system is below the rated speed of the converter. Here the select timing is delayed so that the multiplexer transition takes place after the A/D has completed one conversion cycle and is waiting for the next convert command. As an example: a CLC935 (15Msps) A/D converter is being used at 10 MHz, the conversion takes place in the first 67ns after the convert command, the next 33ns are spent waiting for the next convert command and would be an ideal time to transition the multiplexer from one channel to the next. The second optimization strategy involves lowering the analog input slew rate so that it has fewer high frequency components that might feed through to the hold capacitor while the converter's T/H is in hold mode. This slew rate limitation can be done through the use of the external CLC533 compensation capacitors. Use of this method has the advantage of limiting some of the excess bandwidth that the CLC533 has compared to the ADC. This bandwidth limitation will reduce the amount of high frequency noise that is aliased back into the sampled band. Figure 5 shows recommended C_{COMP} values that can be used as a function of ADC Sample rate. Since the optimal values will change from one ADC to the next, this graph should be used as a starting point for C_{COMP} selection.

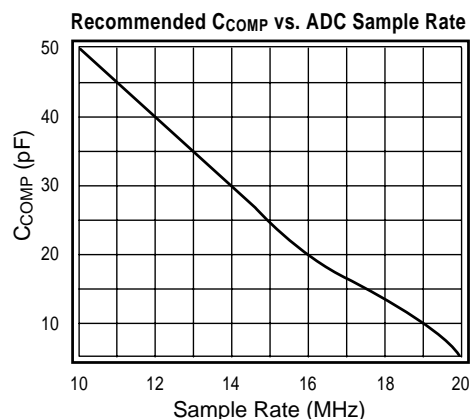

Figure 5

Flash ADCs are similar to subranging ADCs in that the sampling period is very brief. The primary difference is that the acquisition time of a flash converter is much shorter than that of a subranging A/D. With a flash ADC the transition of the mux output should be after the sampling instant (Aperture delay after the convert command). The periods of time during which the internal circuitry in a flash converter is sensitive to external disruptions are relatively brief. It is only during these points in time that the converter is susceptible to interference from the input. It may be found that a slight delay between the ADC clock and the CLC533 select lines will have a positive effect on overall performance.

Mixed Mode Circuit Design

In any mixed mode circuit care must be taken to keep the high slew-rate digital signals from interfering with the high precision analog signals. A successful design will take this into consideration from many angles and will account for it in digital timing, logic family selected, PCB layout, analog signal bandwidth and a myriad of other aspects. Below are a few tips that should be kept in mind when designing a circuit that involves both analog and digital circuitry.

Timing

If the analog signals going through the CLC533 are to be sampled, try to minimize the amount of digital logic switching concurrent with the sampling instant.

Power Supply Net

In an analog system the ideal situation would have each circuit element completely isolated from all others except for the intended connections. One of the most common ways for unwanted connections to be made is through the power supplies and ground. These are often shared by all of the circuits in the system. Refer to the section on power supplies and grounding for tips on how to avoid these pitfalls.

Logic Family Selection

When designing digital logic, there are often several logic families that will provide a solution to the problem at hand. Although they may perform equally in a digital sense, they may have varying degrees of influence on the analog circuits in the same system. Coupling of digital signals with analog signals through stray capacitances is rarely a problem for the digital logic but can be a detrimental to an otherwise good analog design. To minimize coupling, lay out the board to minimize the stray capacitances as much as possible: if an analog and a digital signal must cross, make them cross at right angles and avoid long parallel runs. If a 74LS00 will work in a socket, using a 74F00 will probably have no effect on the digital circuitry, but the faster edges will find it easier to corrupt analog signals. When faced with a choice between several logic families, select the slowest one possible to get the job done. Don't forget that the slew rates of digital logic depend not only on the rise and fall times, but on the output swing as well. ECL gates with a 1ns rise time have much slower slew rates than TTL gates with the same rise times. Do not attempt to slow logic edge rates through the addition of capacitance on the logic lines.

The negative effects that digital logic has on power supplies is not constant through different logic families. CMOS logic draws current only during transitions. The surge currents that it draws at these times can be quite significant and can be very disruptive to the power and ground networks. ECL tends to draw constant amounts of current and has a much smaller effect on the power net.

Gain Selection for an ADC

In many applications, such as RADAR, the dynamic range requirements may exceed the accuracy requirements. Since wide dynamic range ADCs are also typically highly accurate ADCs this often leads the designer into an ADC which is a technical overkill and a budget buster. By using the CLC533 as a selectable gain stage, a less expensive A/D can be used. For example, if an application calls for 85dB of dynamic range and 0.05% accuracy, rather than using a 16 bit converter, use a 12 bit converter with the circuit shown below. In this circuit the CLC533 is used to select between the input signal and version of the input signal attenuated by 6, 12 and 18dB. This circuit affords better than 14 bit dynamic range, 12 bit accuracy and a 12 bit price. By using resistors of all the same value, a single resistor network can be used which can assure good matching of the resistors, even over temperature.

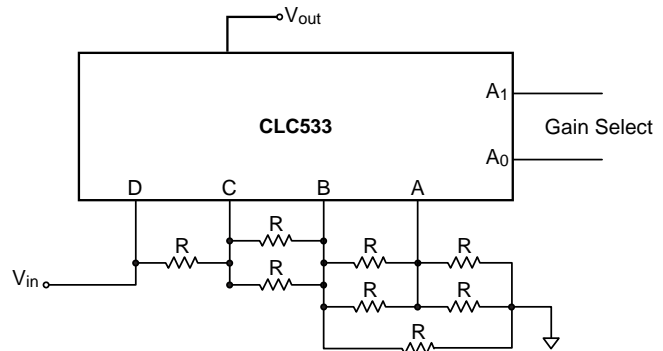

Figure 6

Evaluation Board

Evaluation boards are available for both the DIP versions (Part number CLC730035) and SOIC version (part number CLC730039) of the CLC533. These boards can be used for fast, trouble free evaluation and characterization of the CLC533. Additionally this board serves an example of a successful PCB layout that can be copied into applications circuits. A separate data sheet for the evaluation board can be obtained.

Customer Design Applications Support

National Semiconductor is committed to design excellence. For sales, literature and technical support, call the National Semiconductor Customer Response Group at **1-800-272-9959** or fax **1-800-737-7018**.

Life Support Policy

National's products are not authorized for use as critical components in life support devices or systems without the express written approval of the president of National Semiconductor Corporation. As used herein:

1. Life support devices or systems are devices or systems which, a) are intended for surgical implant into the body, or b) support or sustain life, and whose failure to perform, when properly used in accordance with instructions for use provided in the labeling, can be reasonably expected to result in a significant injury to the user.
2. A critical component is any component of a life support device or system whose failure to perform can be reasonably expected to cause the failure of the life support device or system, or to affect its safety or effectiveness.



National Semiconductor Corporation

1111 West Bardin Road
Arlington, TX 76017
Tel: 1(800) 272-9959
Fax: 1(800) 737-7018

National Semiconductor Europe

Fax: (+49) 0-180-530 85 86
E-mail: europe.support.nsc.com
Deutsch Tel: (+49) 0-180-530 85 85
English Tel: (+49) 0-180-532 78 32
Francais Tel: (+49) 0-180-532 93 58
Italiano Tel: (+49) 0-180-534 16 80

National Semiconductor Hong Kong Ltd.

2501 Miramar Tower
1-23 Kimberley Road
Tsimshatsui, Kowloon
Hong Kong
Tel: (852) 2737-1600
Fax: (852) 2736-9960

National Semiconductor Japan Ltd.

Tel: 81-043-299-2309
Fax: 81-043-299-2408

National does not assume any responsibility for use of any circuitry described, no circuit patent licenses are implied and National reserves the right at any time without notice to change said circuitry and specifications.

This datasheet has been downloaded from:

www.DatasheetCatalog.com

Datasheets for electronic components.

National Semiconductor was acquired by Texas Instruments.

http://www.ti.com/corp/docs/investor_relations/pr_09_23_2011_national_semiconductor.html

This file is the datasheet for the following electronic components:

CLC533AJP - <http://www.ti.com/product/clc533ajp?HQS=TI-null-null-dscatalog-df-pf-null-wwe>

CLC533AMC - <http://www.ti.com/product/clc533amc?HQS=TI-null-null-dscatalog-df-pf-null-wwe>

CLC533AJE - <http://www.ti.com/product/clc533aje?HQS=TI-null-null-dscatalog-df-pf-null-wwe>

CLC533A8L-2A - <http://www.ti.com/product/clc533a8l-2a?HQS=TI-null-null-dscatalog-df-pf-null-wwe>

CLC533A8B - <http://www.ti.com/product/clc533a8b?HQS=TI-null-null-dscatalog-df-pf-null-wwe>

CLC533ALC - <http://www.ti.com/product/clc533alc?HQS=TI-null-null-dscatalog-df-pf-null-wwe>



LittleDiode supplies new, hard to find or obsolete electronic components and semiconductors all over the world.

With over two million different components listed you are sure to find the part you need.

Feel free to visit us today at our online store:

LittleDiode.com

Looking forward to providing you with the best possible service.