

### FEATURES

- 12-Bit Accuracy in an 8-Pin Mini-DIP
- Fast Serial Data Input
- Double Data Buffers
- Low  $\pm 1/2$  LSB Max INL and DNL
- Max Gain Error:  $\pm 1$  LSB
- Low 5 ppm/ $^{\circ}$ C Max Tempco
- ESD Resistant
- Low Cost
- Available in Die Form

### APPLICATIONS

- Autocalibration Systems
- Process Control and Industrial Automation
- Programmable Amplifiers and Attenuators
- Digitally-Controlled Filters

### GENERAL DESCRIPTION

The DAC8043 is a high accuracy 12-bit CMOS multiplying DAC in a space-saving 8-pin mini-DIP package. Featuring serial data input, double buffering, and excellent analog performance, the DAC8043 is ideal for applications where PC board space is at a premium. Also, improved linearity and gain error performance permit reduced parts count through the elimination of trimming components. Separate input clock and load DAC control lines allow full user control of data loading and analog output.

The circuit consists of a 12-bit serial-in, parallel-out shift register, a 12-bit DAC register, a 12-bit CMOS DAC, and control logic. Serial data is clocked into the input register on the rising edge of the CLOCK pulse. When the new data word has been clocked in, it is loaded into the DAC register with the  $\overline{\text{LD}}$  input pin. Data in the DAC register is converted to an output current by the D/A converter.

The DAC8043's fast interface timing may reduce timing design considerations while minimizing microprocessor wait states. For applications requiring an asynchronous CLEAR function or more versatile microprocessor interface logic, refer to the PM-7543.

Operating from a single +5 V power supply, the DAC8043 is the ideal low power, small size, high performance solution to many application problems. It is available in plastic and cerdip packages that are compatible with auto-insertion equipment.

### FUNCTIONAL BLOCK DIAGRAM

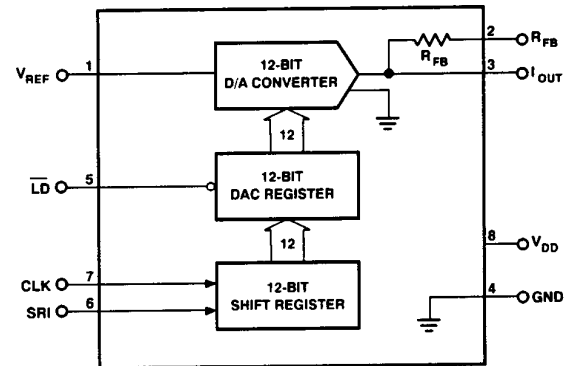

### PIN CONNECTIONS

**8-Pin Epoxy DIP  
(P-Suffix)**

**8-Pin Cerdip  
(Z-Suffix)**

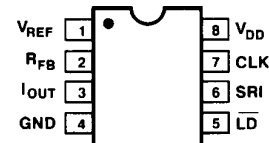

**16-Lead Wide-Body SOL  
(S-Suffix)**

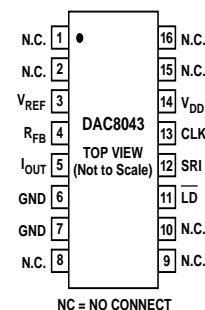

### REV. C

Information furnished by Analog Devices is believed to be accurate and reliable. However, no responsibility is assumed by Analog Devices for its use, nor for any infringements of patents or other rights of third parties which may result from its use. No license is granted by implication or otherwise under any patent or patent rights of Analog Devices.

# DAC8043–SPECIFICATIONS

## ELECTRICAL CHARACTERISTICS (@ $V_{DD} = +5\text{ V}$ ; $V_{REF} = +10\text{ V}$ ; $I_{OUT} = \text{GND} = 0\text{ V}$ ; $T_A = \text{Full Temperature Range}$ specified under Absolute Maximum Ratings unless otherwise noted).

Parameter	Symbol	Conditions	DAC8043			Units
			Min	Typ	Max	
<b>STATIC ACCURACY</b>						
Resolution	N		12			Bits
Nonlinearity (Note 1)	INL	DAC8043A/E/G DAC8043F			$\pm 1/2$ 1	LSB LSB
Differential Nonlinearity (Note 2)	DNL	DAC8043A/E DAC8043F/G			$\pm 1/2$ $\pm 1$	LSB LSB
Gain Error (Note 3)	$G_{FSE}$	$T_A = +25^\circ\text{C}$ DAC8043A/E DAC8043F/G $T_A = \text{Full Temperature Range}$ All Grades			1 2 2	LSB LSB LSB
Gain Tempco ( $\Delta \text{Gain}/\Delta \text{Temp}$ ) (Note 5)	$TC_{GFS}$				$\pm 5$	ppm/ $^\circ\text{C}$
Power Supply Rejection Ratio ( $\Delta \text{Gain}/\Delta V_{DD}$ )	PSRR	$\Delta V_{DD} = \pm 5\%$		$\pm 0.0006$	$\pm 0.002$	%/%
Output Leakage Current (Note 4)	$I_{LKG}$	$T_A = +25^\circ\text{C}$ $T_A = \text{Full Temperature Range}$ DAC8043A DAC8043E/F/G			$\pm 5$ $\pm 100$ $\pm 25$	nA nA nA
Zero Scale Error (Notes 7, 12)	$I_{ZSE}$	$T_A = +25^\circ\text{C}$ $T_A = \text{Full Temperature Range}$ DAC8043A DAC8043E/F/G			0.03 0.61 0.15	LSB LSB LSB
Input Resistance (Note 8)	$R_{IN}$		7	11	15	k $\Omega$
<b>AC PERFORMANCE</b>						
Output Current Settling Time (Notes 5, 6)	$t_S$	$T_A = +25^\circ\text{C}$		0.25	1	$\mu\text{s}$
Digital to Analog Glitch Energy (Note 5, 10)	Q	$V_{REF} = 0\text{ V}$ $I_{OUT} \text{ Load} = 100\ \Omega$ $C_{EXT} = 13\ \text{pF}$ DAC Register Loaded Alternately with All 0s and All 1s		2	20	nVs
Feedthrough Error ( $V_{REF}$ to $I_{OUT}$ ) (Note 5, 11)	FT	$V_{REF} = 20\ \text{V p-p @ } f = 10\ \text{kHz}$ Digital Input = 0000 0000 0000 $T_A = +25^\circ\text{C}$		0.7	1	mV p-p
Total Harmonic Distortion (Note 5)	THD	$V_{REF} = 6\ \text{V rms @ } 1\ \text{kHz}$ DAC Register Loaded with All 1s		-85		dB
Output Noise Voltage Density (Note 5, 13)	$e_n$	10 Hz to 100 kHz between $R_{FB}$ and $I_{OUT}$			17	nV/ $\sqrt{\text{Hz}}$
<b>DIGITAL INPUTS</b>						
Digital Input HIGH	$V_{IN}$		2.4			V
Digital Input LOW	$V_{IL}$				0.8	V
Input Leakage Current (Note 9)	$I_{IL}$	$V_{IN} = 0\text{ V to } +5\text{ V}$			$\pm 1$	$\mu\text{A}$
Input Capacitance (Note 5, 11)	$C_{IN}$	$V_{IN} = 0\text{ V}$			8	pF
<b>ANALOG OUTPUTS</b>						
Output Capacitance (Note 5)	$C_{OUT}$	Digital Inputs = $V_{IH}$ Digital Inputs = $V_{IL}$			110 80	pF pF

Parameter	Symbol	Conditions	DAC8043			Units
			Min	Typ	Max	
TIMING CHARACTERISTICS (NOTES 5, 14)						
Data Setup Time	$t_{DS}$	$T_A = \text{Full Temperature Range}$	40			ns
Data Hold Time	$t_{DH}$	$T_A = \text{Full Temperature Range}$	80			ns
Clock Pulse Width High	$t_{CH}$	$T_A = \text{Full Temperature Range}$	90			ns
Clock Pulse Width Low	$t_{CL}$	$T_A = \text{Full Temperature Range}$	120			ns
Load Pulse Width	$t_{LD}$	$T_A = \text{Full Temperature Range}$	120			ns
LSB Clock Into Input Register to Load DAC Register Time	$t_{ASB}$	$T_A = \text{Full Temperature Range}$	0			ns
POWER SUPPLY						
Supply Voltage	$V_{DD}$		4.75	5	5.25	V
Supply Current	$I_{DD}$	Digital Inputs = $V_{IH}$ or $V_{IL}$ Digital Inputs = 0 V or $V_{DD}$			500	$\mu\text{A max}$
					100	$\mu\text{A max}$

## NOTES

- <sup>1</sup> $\pm 1/2$  LSB =  $\pm 0.012\%$  of full scale.
- <sup>2</sup>All grades are monotonic to 12-bits over temperature.
- <sup>3</sup>Using internal feedback resistor.
- <sup>4</sup>Applies to  $I_{OUT}$ ; All digital inputs = 0 V.
- <sup>5</sup>Guaranteed by design and not tested.
- <sup>6</sup> $I_{OUT}$  Load = 100  $\Omega$ ,  $C_{EXT}$  = 13 pF, digital input = 0 V to  $V_{DD}$  or  $V_{DD}$  to 0 V. Extrapolated to 1/2 LSB;  $t_S$  = propagation delay ( $t_{PD}$ ) +  $9\tau$  where  $\tau$  = measured time constant of the final RC decay.
- <sup>7</sup> $V_{REF}$  = +10 V, all digital inputs = 0 V.
- <sup>8</sup>Absolute temperature coefficient is less than +300 ppm/ $^{\circ}\text{C}$ .
- <sup>9</sup>Digital inputs are CMOS gates;  $I_{IN}$  is typically 1 nA at +25 $^{\circ}\text{C}$ .
- <sup>10</sup> $V_{REF}$  = 0 V, all digital inputs = 0 V to  $V_{DD}$  or  $V_{DD}$  to 0 V.
- <sup>11</sup>All digit inputs = 0 V.
- <sup>12</sup>Calculated from worst case  $R_{REF}$ :  $I_{ZSE}$  (in LSBs) =  $(R_{REF} \times I_{LKG} \times 4096) / V_{REF}$ .
- <sup>13</sup>Calculations from  $en = \sqrt{4K TRB}$  where: K = Boltzmann constant, J/ $^{\circ}\text{K}$ , R = resistance,  $\Omega$ , T = resistor temperature,  $^{\circ}\text{K}$ , B = bandwidth, Hz.
- <sup>14</sup>Tested at  $V_{IN}$  = 0 V or  $V_{DD}$ .

Specifications subject to change without notice.

## ABSOLUTE MAXIMUM RATINGS

( $T_A = +25^{\circ}\text{C}$  unless otherwise noted)

$V_{DD}$ to GND	.....	+17 V
$V_{REF}$ to GND	.....	$\pm 25$ V
$V_{RFB}$ to GND	.....	$\pm 25$ V
Digital Input Voltage Range	.....	-0.3 V to $V_{DD}$
Output Voltage (Pin 3)	.....	-0.3 V to $V_{DD}$
Operating Temperature Range		
AZ Versions	.....	-55 $^{\circ}\text{C}$ to +125 $^{\circ}\text{C}$
EZ/FZ/FP Versions	.....	-40 $^{\circ}\text{C}$ to +85 $^{\circ}\text{C}$
GP Version	.....	0 $^{\circ}\text{C}$ to +70 $^{\circ}\text{C}$
Junction Temperature	.....	+150 $^{\circ}\text{C}$
Storage Temperature	.....	-65 $^{\circ}\text{C}$ to +150 $^{\circ}\text{C}$
Lead Temperature (Soldering, 60 sec)	.....	+300 $^{\circ}\text{C}$

Package Type	$\theta_{JA}$ *	$\theta_{JC}$	Units
8-Pin Hermetic DIP (Z)	134	12	$^{\circ}\text{C/W}$
8-Pin Plastic DIP (P)	96	37	$^{\circ}\text{C/W}$

\* $\theta_{JA}$  is specified for worst case mounting conditions, i. e.,  $\theta_{JA}$  is specified for device in socket for cerdip and P-DIP packages.

## CAUTION

1. Do not apply voltages higher than  $V_{DD}$  or less than GND potential on any terminal except  $V_{REF}$  (Pin 1) and  $R_{FB}$  (Pin 2).
2. The digital control inputs are Zener-protected; however, permanent damage may occur on unprotected units from high energy electrostatic fields. Keep units in conductive foam at all times until ready to use.
3. Use proper antistatic handling procedures.
4. Absolute Maximum Ratings apply to both packaged devices and DICE. Stresses above those listed under Absolute Maximum Ratings may cause permanent damage to the device.

## ORDERING GUIDE<sup>1</sup>

Model	Relative Accuracy	Temperature Range	Package Option
DAC8043AZ <sup>2</sup>	$\pm 1/2$ LSB	-55 $^{\circ}\text{C}$ to +125 $^{\circ}\text{C}$	8-Pin Cerdip
DAC8043AZ/883 <sup>2</sup>	$\pm 1/2$ LSB	-55 $^{\circ}\text{C}$ to +125 $^{\circ}\text{C}$	8-Pin Cerdip
DAC8043EZ	$\pm 1/2$ LSB	-40 $^{\circ}\text{C}$ to +125 $^{\circ}\text{C}$	8-Pin Cerdip
DAC8043FS	$\pm 1$ LSB	-40 $^{\circ}\text{C}$ to +85 $^{\circ}\text{C}$	16-Lead (Wide) SOL
DAC8043FZ	$\pm 1$ LSB	-40 $^{\circ}\text{C}$ to +85 $^{\circ}\text{C}$	8-Pin Cerdip
DAC8043FP	$\pm 1$ LSB	-40 $^{\circ}\text{C}$ to +85 $^{\circ}\text{C}$	8-Pin Epoxy DIP
DAC8043GP	$\pm 1/2$ LSB	0 $^{\circ}\text{C}$ to +70 $^{\circ}\text{C}$	8-Pin Epoxy DIP
DAC8043HP	$\pm 1$ LSB	0 $^{\circ}\text{C}$ to +70 $^{\circ}\text{C}$	8-Pin Epoxy DIP

## NOTES

- <sup>1</sup>All commercial and industrial temperature range parts are available with burn-in.
- <sup>2</sup>For devices processed in total compliance to MIL-STD-883, add/883 after part number. Consult factory for 883 data sheet.

# DAC8043

## WAFER TEST LIMITS @ $V_{DD} = +5\text{ V}$ , $V_{REF} = +10\text{ V}$ ; $I_{OUT} = \text{GND} = 0\text{ V}$ , $T_A = +25^\circ\text{C}$ .

Parameter	Symbol	Conditions	DAC8043GBC Limit	Units
<b>STATIC ACCURACY</b>				
Resolution	N		12	Bits min
Integral Nonlinearity	INL		$\pm 1$	LSB max
Differential Nonlinearity	DNL		$\pm 1$	LSB max
Gain Error	$G_{FSE}$	Using Internal Feedback Resistor	$\pm 2$	LSB max
Power Supply Rejection Ratio	PSRR	$\Delta V_{DD} = \pm 5\%$	$\pm 0.002$	%/% max
Output Leakage Current ( $I_{OUT}$ )	$I_{LKG}$	Digital Inputs = $V_{IL}$	$\pm 5$	nA max
<b>REFERENCE INPUT</b>				
Input Resistance	$R_{IN}$		7/15	k $\Omega$ min/max
<b>DIGITAL INPUTS</b>				
Digital Input HIGH	$V_{IH}$	$V_{IN} = 0\text{ V to }V_{DD}$	2.4	V min
Digital Input LOW	$V_{IL}$		0.8	V max
Input Leakage Current	$I_{IL}$		$\pm 1$	$\mu\text{A}$ max
<b>POWER SUPPLY</b>				
Supply Current	$I_{DD}$	Digital Inputs = $V_{IN}$ or $V_{IL}$	500	$\mu\text{A}$ max
		Digital Inputs = 0 V or $V_{DD}$	100	$\mu\text{A}$ max

**NOTE**  
Electrical tests are performed at wafer probe to the limits shown. Due to variations in assembly methods and normal yield loss, yield after packaging is not guaranteed for standard product dice. Consult factory to negotiate specifications based on dice lot qualifications through sample lot assembly and testing.

### DICE CHARACTERISTICS

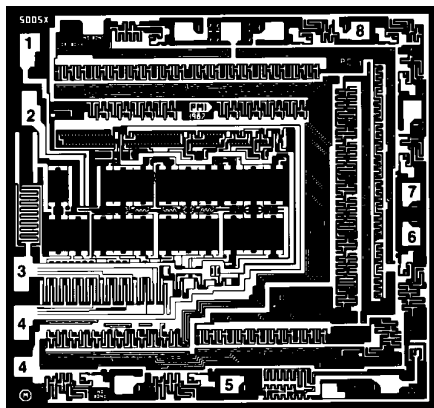

1.  $V_{REF}$
2.  $R_{FB}$
3.  $I_{OUT}$
4. GND
5.  $\overline{LD}$
6. SRI
7. CLK
8.  $V_{DD}$

Substate (die backside) is internally connected to  $V_{DD}$ .

DIE SIZE 0.116 × 0.109 inch, 12,644 sq. mils (2.95 × 2.77 mm, 8.17 sq. mm)

### CAUTION

ESD (electrostatic discharge) sensitive device. Electrostatic charges as high as 4000 V readily accumulate on the human body and test equipment and can discharge without detection. Although the DAC8043 features proprietary ESD protection circuitry, permanent damage may occur on devices subjected to high energy electrostatic discharges. Therefore, proper ESD precautions are recommended to avoid performance degradation or loss of functionality.



TYPICAL PERFORMANCE CHARACTERISTICS

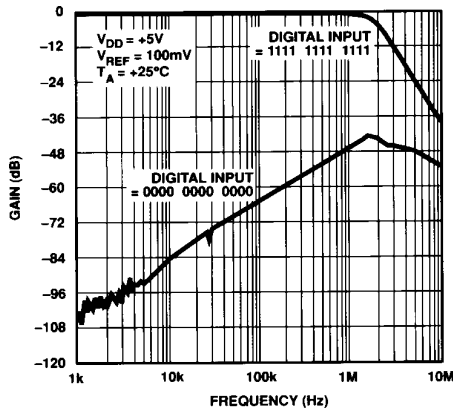

Gain vs. Frequency (Output Amplifier: OP42)

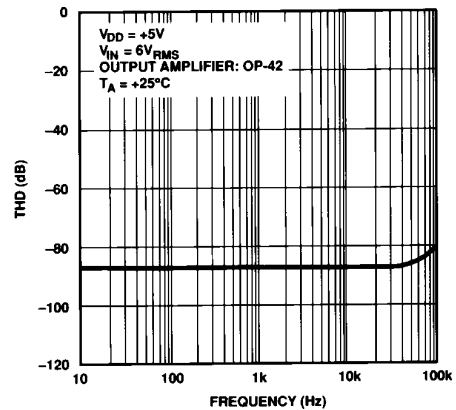

Total Harmonic Distortion vs. Frequency (Multiplying Mode)

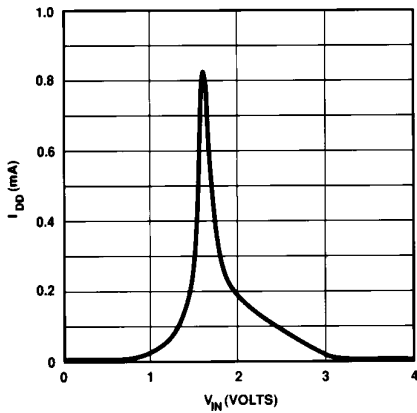

Supply Current vs. Logic Input Voltage

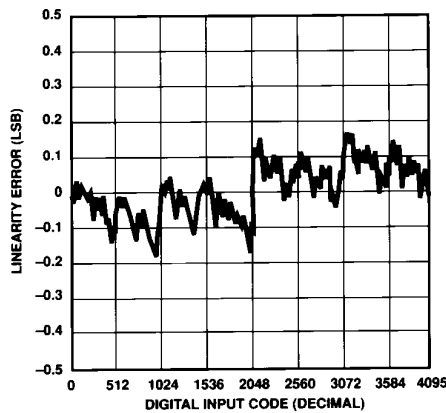

Linearity Error vs. Digital Code

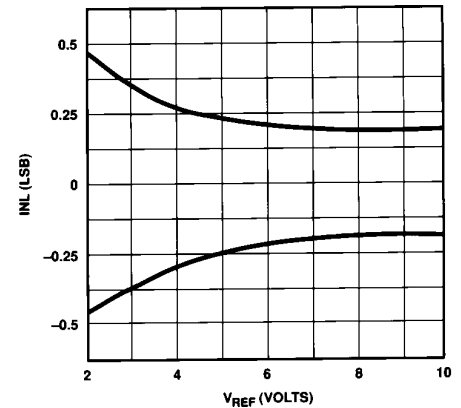

Linearity Error vs. Reference Voltage

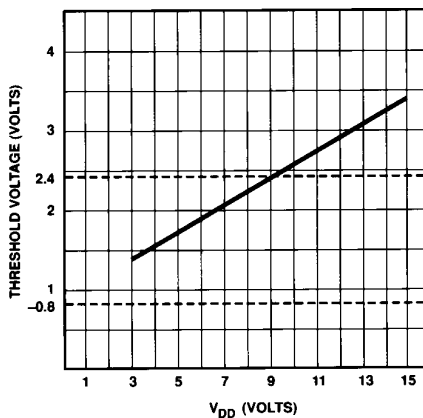

Logic Threshold Voltage vs. Supply Voltage

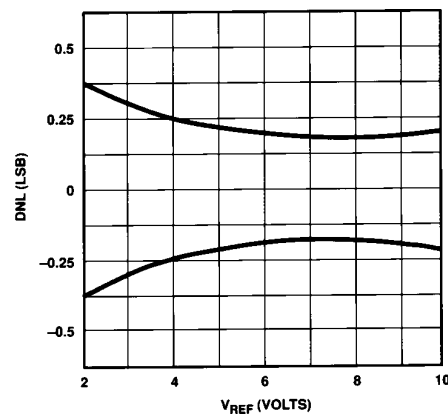

DNL Error vs. Reference Voltage

# DAC8043

## PARAMETER DEFINITIONS

### INTEGRAL NONLINEARITY (INL)

This is the single most important DAC specification. ADI measures INL as the maximum deviation of the analog output (from the ideal) from a straight line drawn between the end points. It is expressed as a percent of full-scale range or in terms of LSBs.

Refer to PMI 1988 Data Book section 11 for additional digital-to-analog converter definitions.

### INTERFACE LOGIC INFORMATION

The DAC8043 has been designed for ease of operation. The timing diagram illustrates the input register loading sequence. Note that the most significant bit (MSB) is loaded first.

Once the input register is full, the data is transferred to the DAC register by taking  $\overline{LD}$  momentarily low.

### DIGITAL SECTION

The DAC8043's digital inputs, SRI,  $\overline{LD}$ , and CLK, are TTL compatible. The input voltage levels affect the amount of current drawn from the supply; peak supply current occurs as the digital input ( $V_{IN}$ ) passes through the transition region. See the Supply Current vs. Logic Input Voltage graph located under the typical performance characteristics curves. Maintaining the digital input voltage levels as close as possible to the supplies,  $V_{DD}$  and GND, minimizes supply current consumption.

The DAC8043's digital inputs have been designed with ESD resistance incorporated through careful layout and the inclusion of input protection circuitry. Figure 1 shows the input protection diodes and series resistor; this input structure is duplicated on each digital input. High voltage static charges applied to the inputs are shunted to the supply and ground rails through forward biased diodes. These protection diodes were designed to clamp the inputs to well below dangerous levels during static discharge conditions.

### GENERAL CIRCUIT INFORMATION

The DAC8043 is a 12-bit multiplying D/A converter with a very low temperature coefficient. It contains an R-2R resistor ladder network, data input and control logic, and two data registers.

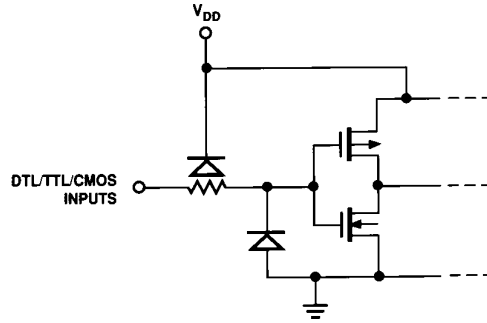

Figure 1. Digital Input Protection

The digital circuitry forms an interface in which serial data can be loaded under microprocessor control into a 12-bit shift register and then transferred, in parallel, to the 12-bit DAC register.

A simplified circuit of the DAC8043 is shown in Figure 2. An inverted R-2R ladder network consisting of silicon-chrome, highly-stable (+50 ppm/°C) thin-film resistors, and twelve pairs of NMOS current-steering switches.

These switches steer binarily weighted currents into either  $I_{OUT}$  or GND; this yields a constant current in each ladder leg, regardless of digital input code. This constant current results in a constant input resistance at  $V_{REF}$  equal to R. The  $V_{REF}$  input may be driven by any reference voltage or current, ac or dc that is within the limits stated in the Absolute Maximum Ratings.

The twelve output current-steering NMOS FET switches are in series with each R-2R resistor, they can introduce bit errors if all are of the same  $R_{ON}$  resistance value. They were designed such that the switch "ON" resistance be binarily scaled so that the voltage drop across each switch remains constant. If, for example, switch 1 of Figure 2 was designed with an "ON" resistance of 10  $\Omega$ , switch 2 for 20  $\Omega$ , etc., a constant 5 mV drop will then be maintained across each switch.

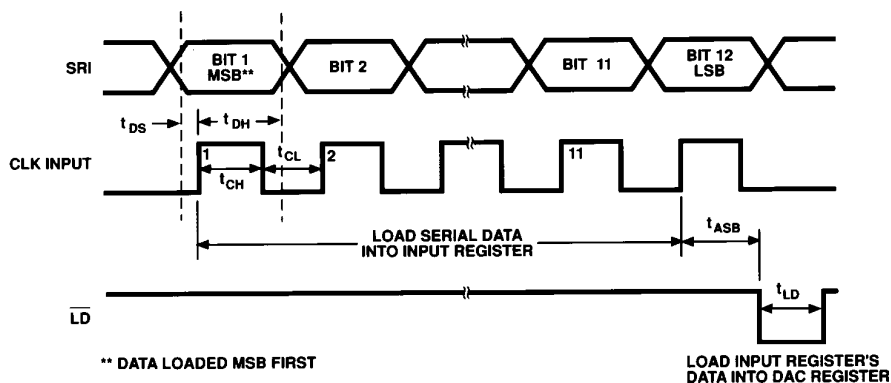

Write Cycle Timing Diagram

To further insure accuracy across the full temperature range, permanently "ON" MOS switches were included in series with the feedback resistor and the R-2R ladder's terminating resistor. The "Simplified DAC Circuit," Figure 2, shows the location of the series switches. These series switches are equivalently scaled to two times switch 1 (MSB) and to switch 12 (LSB) respectively to maintain constant relative voltage drops with varying temperature. During any testing of the resistor ladder or  $R_{FEEDBACK}$  (such as incoming inspection),  $V_{DD}$  must be present to turn "ON" these series switches.

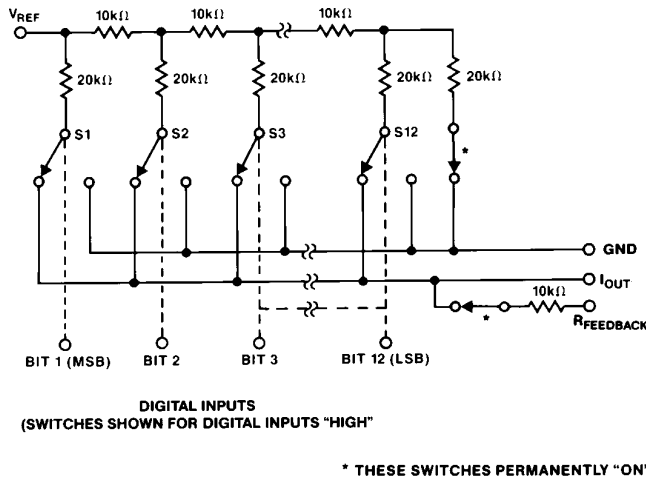

Figure 2. Simplified DAC Circuit

### EQUIVALENT CIRCUIT ANALYSIS

Figure 3 shows an equivalent analog circuit for the DAC8043. The  $(D \times V_{REF})/R$  current source is code dependent and is the current generated by the DAC. The current source  $I_{LKG}$  consists of surface and junction leakages and doubles approximately every  $10^\circ\text{C}$ .  $C_{OUT}$  is the output capacitance; it is the result of the N-channel MOS switches and varies from 80 pF to 110 pF depending on the digital input code.  $R_O$  is the equivalent output resistance that also varies with digital input code.  $R$  is the nominal R-2R resistor ladder resistance.

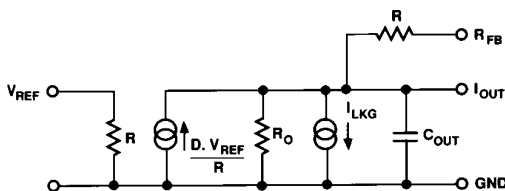

Figure 3. Equivalent Analog Circuit

### DYNAMIC PERFORMANCE

#### OUTPUT IMPEDANCE

The DAC8043's output resistance, as in the case of the output capacitance, varies with the digital input code. This resistance, looking back into the  $I_{OUT}$  terminal, may be between  $10\text{ k}\Omega$  (the feedback resistor alone when all digital inputs are LOW) and  $7.5\text{ k}\Omega$  (the feedback resistor in parallel with approximate  $30\text{ k}\Omega$  of the R-2R ladder network resistance when any single bit logic is HIGH). Static accuracy and dynamic performance will be affected by these variations.

This variation is best illustrated by using the circuit of Figure 4 and the equation:

$$V_{ERROR} = V_{OS} \left( 1 + \frac{R_{FB}}{R_O} \right)$$

where  $R_O$  is a function of the digital code, and:

$$R_O = 10\text{ k}\Omega \text{ for more than four bits of logic 1.}$$

$$R_O = 30\text{ k}\Omega \text{ for any single bit of logic 1.}$$

Therefore, the offset gain varies as follows:

at code 0011 1111 1111,

$$V_{ERROR1} = V_{OS} \left( 1 + \frac{10\text{ k}\Omega}{10\text{ k}\Omega} \right) = 2 V_{OS}$$

at code 0100 0000 0000,

$$V_{ERROR2} = V_{OS} \left( 1 + \frac{10\text{ k}\Omega}{30\text{ k}\Omega} \right) = 4/3 V_{OS}$$

The error difference is  $2/3 V_{OS}$ .

Since one LSB has a weight (for  $V_{REF} = +10\text{ V}$ ) of 2.4 mV for the DAC8043, it is clearly important that  $V_{OS}$  be minimized, either using the amplifier's nulling pins, an external nulling network, or by selection of an amplifier with inherently low  $V_{OS}$ . Amplifiers with sufficiently low  $V_{OS}$  include ADI's OP77, OP07, OP27, and OP42.

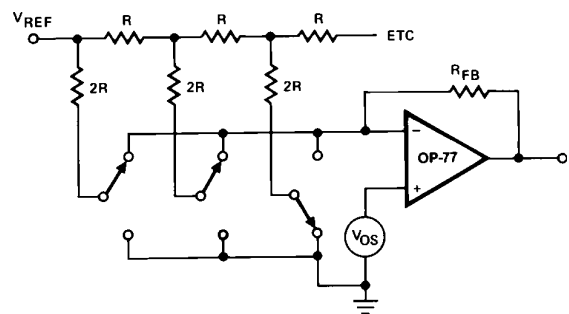

Figure 4. Simplified Circuit

# DAC8043

The gain and phase stability of the output amplifier, board layout, and power supply decoupling will all affect the dynamic performance. The use of a small compensation capacitor may be required when high-speed operational amplifiers are used. It may be connected across the amplifier's feedback resistor to provide the necessary phase compensation to critically damp the output. The DAC8043's output capacitance and the  $R_{FB}$  resistor form a pole that must be outside the amplifier's unity gain crossover frequency.

The considerations when using high-speed amplifiers are:

1. Phase compensation (see Figures 5 and 6).
2. Power supply decoupling at the device socket and use of proper grounding techniques.

## APPLICATIONS INFORMATION

### APPLICATION TIPS

In most applications, linearity depends upon the potential of  $I_{OUT}$  and GND (pins 3 and 4) being exactly equal to each other. In most applications, the DAC is connected to an external op amp with its noninverting input tied to ground (see Figures 5 and 6). The amplifier selected should have a low input bias current and low drift over temperature. The amplifier's input offset voltage should be nulled to less than  $+200 \mu\text{V}$  (less than 10% of 1 LSB).

The operational amplifier's noninverting input should have a minimum resistance connection to ground; the usual bias current compensation resistor should not be used. This resistor can cause a variable offset voltage appearing as a varying output error. All grounded pins should tie to a single common ground point, avoiding ground loops. The  $V_{DD}$  power supply should have a low noise level with no transients greater than  $+17 \text{ V}$ .

### UNIPOLAR OPERATION (2-QUADRANT)

The circuit shown in Figures 5 and 6 may be used with an ac or dc reference voltage. The circuit's output will range between 0 V and approximately  $-V_{REF}$  (4095/4096) depending upon the digital input code. The relationship between the digital input and

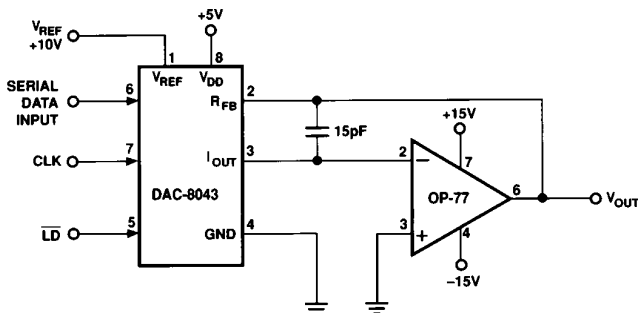

Figure 5. Unipolar Operation with High Accuracy Op Amp (2-Quadrant)

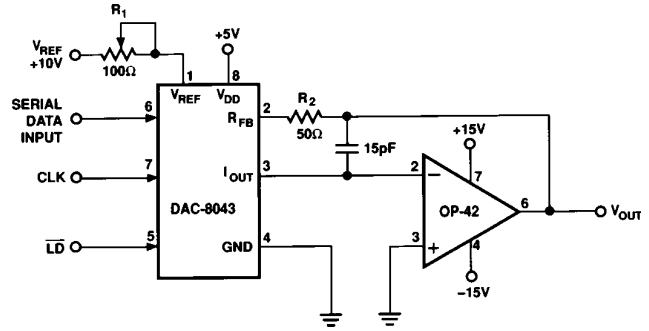

Figure 6. Unipolar Operation with Fast Op Amp and Gain Error Trimming (2-Quadrant)

the analog output is shown in Table I. The limiting parameters for the  $V_{REF}$  range are the maximum input voltage range of the op amp or  $\pm 25 \text{ V}$ , whichever is lowest.

Gain error may be trimmed by adjusting  $R_1$  as shown in Figure 6. The DAC register must first be loaded with all 1s.  $R_1$  may then be adjusted until  $V_{OUT} = -V_{REF}$  (4095/4096). In the case of an adjustable  $V_{REF}$ ,  $R_1$  and  $R_2$  may be omitted, with  $V_{REF}$  adjusted to yield the desired full-scale output.

In most applications the DAC8043's negligible zero scale error and very low gain error permit the elimination of the trimming components ( $R_1$  and the external  $R_2$ ) without adverse effects on circuit performance.

Table I. Unipolar Code Table

Digital Input MSB	LSB	Nominal Analog Output ( $V_{OUT}$ as shown in Figures 5 and 6)
1111	1111 1111	$-V_{REF} \left( \frac{4095}{4096} \right)$
1000	0000 0001	$-V_{REF} \left( \frac{2049}{4096} \right)$
1000	0000 0000	$-V_{REF} \left( \frac{2048}{4096} \right) = -\frac{V_{REF}}{2}$
0111	1111 1111	$-V_{REF} \left( \frac{2047}{4096} \right)$
0000	0000 0001	$-V_{REF} \left( \frac{1}{4096} \right)$
0000	0000 0000	$-V_{REF} \left( \frac{0}{4096} \right) = 0$

#### NOTES

<sup>1</sup>Nominal full scale for the circuits of Figures 5 and 6 is given by

$$FS = -V_{REF} \left( \frac{4095}{4096} \right)$$

<sup>2</sup>Nominal LSB magnitude for the circuits of Figures 5 and 6 is given by

$$LSB = V_{REF} \left( \frac{1}{4096} \right) \text{ or } V_{REF} (2^{-n}).$$

**Table II. Bipolar (Offset Binary) Code Table**

Digital Input MSB	LSB	Nominal Analog Output ( $V_{OUT}$ as Shown in Figure 7)
1111	1111 1111	$+V_{REF} \left( \frac{2047}{2048} \right)$
1000	0000 0001	$+V_{REF} \left( \frac{1}{2048} \right)$
1000	0000 0000	0
0111	1111 1111	$-V_{REF} \left( \frac{1}{2048} \right)$
0000	0000 0001	$-V_{REF} \left( \frac{2047}{2048} \right)$
0000	0000 0000	$-V_{REF} \left( \frac{2048}{2048} \right)$

**NOTES**

<sup>1</sup>Nominal full scale for the circuit of Figure 7 is given by

$$FS = V_{REF} \left( \frac{2047}{2048} \right).$$

<sup>2</sup>Nominal LSB magnitude for the circuit of Figure 7 is given by

$$LSB = V_{REF} \left( \frac{1}{2048} \right).$$

**BIPOLAR OPERATION (4-QUADRANT)**

Figure 7 details a suggested circuit for bipolar, or offset binary operation. Table II shows the digital input to analog output relationship. The circuit uses offset binary coding. Two's complement code can be converted to offset binary by software inversion of the MSB or by the addition of an external inverter to the MSB input.

Resistors  $R_3$ ,  $R_4$ , and  $R_5$  must be selected to match within 0.01% and must all be of the same (preferably metal foil) type to assure temperature coefficient matching. Mismatching between  $R_3$  and  $R_4$  causes offset and full scale errors while an  $R_5$  to  $R_4$  and  $R_3$  mismatch will result in full-scale error.

Calibration is performed by loading the DAC register with 1000 0000 0000 and adjusting  $R_1$  until  $V_{OUT} = 0$  V.  $R_1$  and  $R_2$  may be omitted, adjusting the ratio of  $R_3$  to  $R_4$  to yield  $V_{OUT} = 0$  V. Full scale can be adjusted by loading the DAC register with 1111 1111 1111 and either adjusting the amplitude of  $V_{REF}$  or the value of  $R_5$  until the desired  $V_{OUT}$  is achieved.

**ANALOG/DIGITAL DIVISION**

The transfer function for the DAC8043 connected in the multiplying mode as shown in Figures 5, 6 and 7 is:

$$V_O = -V_{IN} \left( \frac{A_1}{2^1} + \frac{A_2}{2^2} + \frac{A_3}{2^3} + \dots + \frac{A_{12}}{2^{12}} \right)$$

where  $A_X$  assumes a value of 1 for an "ON" bit and 0 for an "OFF" bit.

The transfer function is modified when the DAC is connected in the feedback of an operational amplifier as shown in Figure 8 and becomes:

$$V_O = \left( \frac{-V_{IN}}{\frac{A_1}{2^1} + \frac{A_2}{2^2} + \frac{A_3}{2^3} + \dots + \frac{A_{12}}{2^{12}}} \right)$$

The above transfer function is the division of an analog voltage ( $V_{REF}$ ) by a digital word. The amplifier goes to the rails with all bits "OFF" since division by zero is infinity. With all bits "ON," the gain is 1 ( $\pm 1$  LSB). The gain becomes 4096 with the LSB, bit 12 "ON."

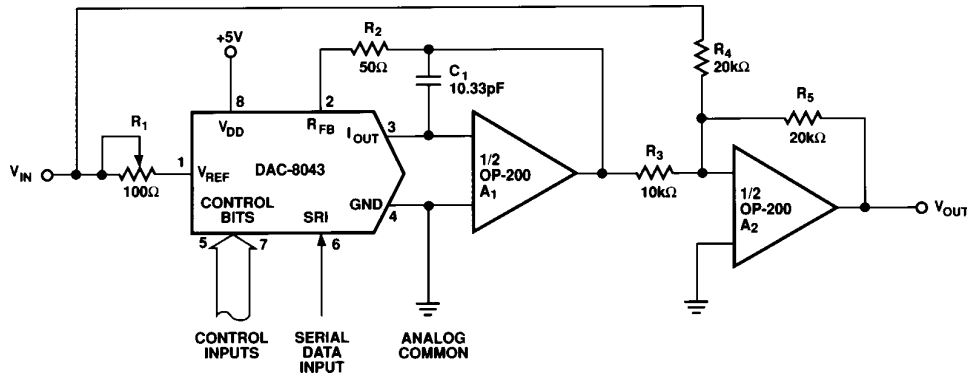

Figure 7. Bipolar Operation (4-Quadrant, Offset Binary)

# DAC8043

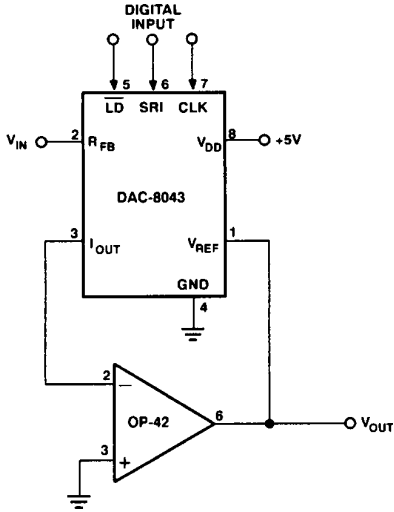

Figure 8. Analog/Digital Divider

## INTERFACING TO THE MC6800

As shown in Figure 9, the DAC8043 may be interfaced to the 6800 by successively executing memory WRITE instructions while manipulating the data between WRITES, so that each WRITE presents the next bit.

In this example the most significant bits are found in memory location 0000 and 0001. The four MSBs are found in the lower half of 0000, the eight LSBs in 0001. The data is taken from the DB<sub>7</sub> line.

The serial data loading is triggered by the CLK pulse which is asserted by a decoded memory WRITE to memory location 2000, R/W, and  $\phi_2$ . A WRITE to address 4000 transfers data from input register to DAC register.

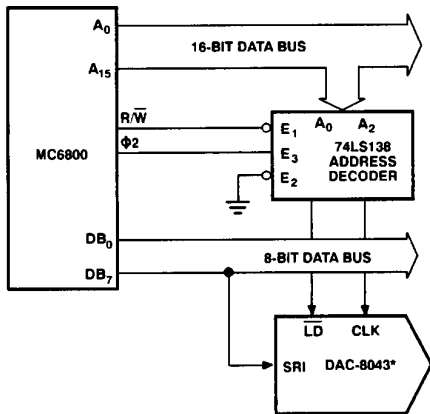

\* ANALOG CIRCUITRY OMITTED FOR SIMPLICITY

Figure 9. DAC8043-MC6800 Interface

## DAC8043 INTERFACE TO THE 8085

The DAC8043's interface to the 8085 microprocessor is shown in Figure 10. Note that the microprocessor's SOD line is used to present data serially to the DAC.

Data is clocked into the DAC8043 by executing memory write instructions. The clock input is generated by decoding address 8000 and WR. Data is loaded into the DAC register with a memory write instruction to address A000.

Serial data supplied to the DAC8043 must be present in the right justified format in registers H and L of the microprocessor.

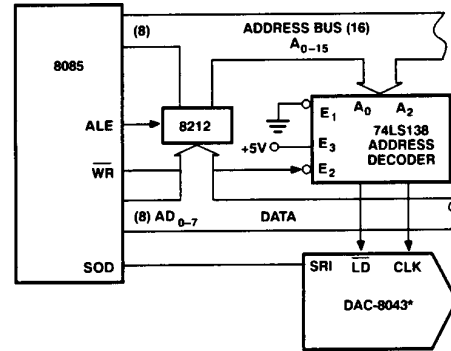

\* ANALOG CIRCUITRY OMITTED FOR SIMPLICITY

Figure 10. DAC8043-8085 Interface

## DAC8043 TO 68000 INTERFACING

The DAC8043 interfacing to the 68000 microprocessor is shown in Figure 11. Again, serial data to the DAC is taken from one of the microprocessor's data bus lines.

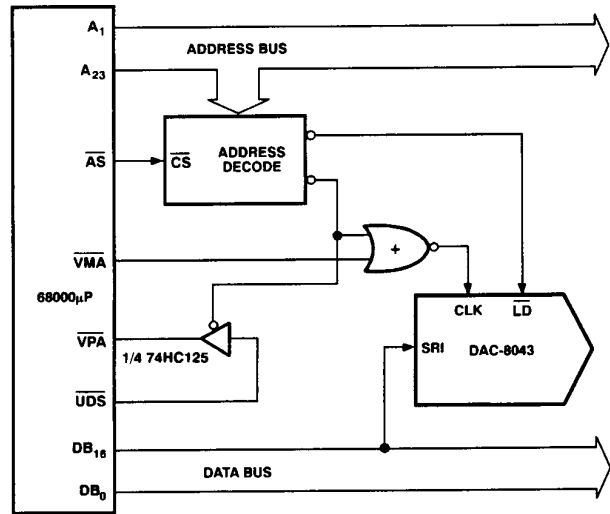

Figure 11. DAC8043-68000  $\mu$ P Interface







LittleDiode supplies new, hard to find or obsolete electronic components and semiconductors all over the world.

With over two million different components listed you are sure to find the part you need.

Feel free to visit us today at our online store:

[LittleDiode.com](http://LittleDiode.com)

Looking forward to providing you with the best possible service.