

**OBSOLETE PRODUCT  
FOR A POSSIBLE SUBSTITUTE PRODUCT  
contact our Technical Support Center at  
1-888-INTERSIL or www.intersil.com/tsc**

# ICL7109

## 12-Bit, Microprocessor- Compatible A/D Converter

November 2000

### Features

- 12-Bit Binary (Plus Polarity and Over-Range) Dual Slope Integrating Analog-to-Digital Converter
- Byte-Organized, TTL Compatible Three-State Outputs and UART Handshake Mode for Simple Parallel or Serial Interfacing to Microprocessor Systems
- RUN/HOLD Input and STATUS Output Can Be Used to Monitor and Control Conversion Timing
- True Differential Input and Differential Reference
- Low Noise (Typ) ..... 15 $\mu$ V<sub>p-p</sub>
- Input Current (Typ) ..... 1pA
- Operates At Up to 30 Conversions/s
- On-Chip Oscillator Operates with Inexpensive 3.58MHz TV Crystal Giving 7.5 Conversions/s for 60Hz Rejection. May Also Be Used with An RC Network Oscillator for Other Clock Frequencies

### Part Number Information

PART NUMBER	TEMP. RANGE (°C)	PACKAGE	PKG. NO.
ICL7109MDL	-55 to 125	40 Ld SBDIP	D40.6
ICL7109IDL	-25 to 85	40 Ld SBDIP	D40.6
ICL7109IJL	-25 to 85	40 Ld CERDIP	F40.6
ICL7109CPL	0 to 70	40 Ld PDIP	E40.6
ICL7109MDL/883B	-55 to 125	40 Ld SBDIP	D40.6
ICL7109IPL	-25 to 85	40 Ld PDIP	E40.6

### Description

The ICL7109 is a high performance, CMOS, low power integrating A/D converter designed to easily interface with microprocessors.

The output data (12 bits, polarity and over-range) may be directly accessed under control of two byte enable inputs and a chip select input for a single parallel bus interface. A UART handshake mode is provided to allow the ICL7109 to work with industry-standard UARTs in providing serial data transmission. The RUN/HOLD input and STATUS output allow monitoring and control of conversion timing.

The ICL7109 provides the user with the high accuracy, low noise, low drift versatility and economy of the dual-slope integrating A/D converter. Features like true differential input and reference, drift of less than 1 $\mu$ V/°C, maximum input bias current of 10pA, and typical power consumption of 20mW make the ICL7109 an attractive per-channel alternative to analog multiplexing for many data acquisition applications.

### Pinout

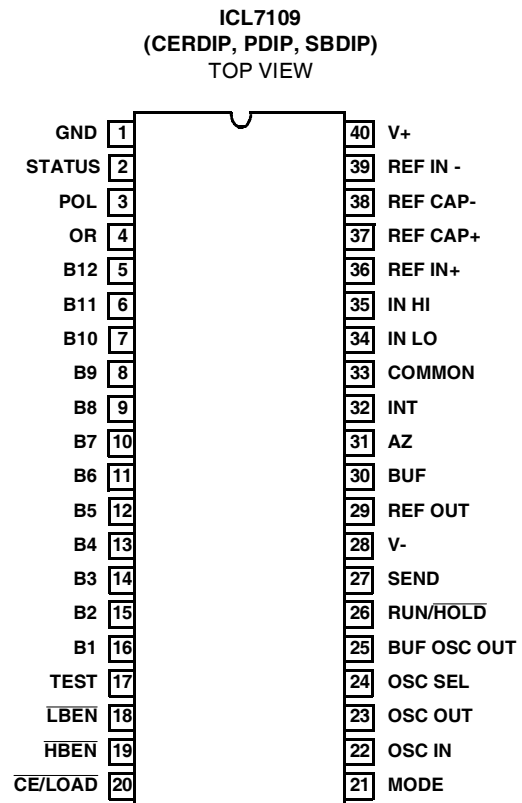

# ICL7109

## Absolute Maximum Ratings

Positive Supply Voltage (GND to V+)	+6.0V
Negative Supply Voltage (GND to V-)	-9V
Analog Input Voltage (Either Input) (Note 1)	V+ to V-
Reference Input Voltage (Either Input) (Note 1)	V+ to V-
Digital Input Voltage	(V+) +0.3V
Pins 2-27 (Note 2)	GND -0.3V

## Operating Conditions

Temperature Range	
M Suffix	-55°C to 125°C
I Suffix	-25°C to 85°C
C Suffix	0°C to 75°C

CAUTION: Stresses above those listed in "Absolute Maximum Ratings" may cause permanent damage to the device. This is a stress only rating and operation of the device at these or any other conditions above those indicated in the operational sections of this specification is not implied.

### NOTE:

1.  $\theta_{JA}$  is measured with the component mounted on an evaluation PC board in free air.

## Thermal Information

Thermal Resistance (Typical, Note 1)	$\theta_{JA}$ (°C/W)	$\theta_{JC}$ (°C/W)
SBDIP Package	60	20
CERDIP Package	55	18
PDIP Package	50	N/A
Maximum Junction Temperature (PDIP Package)	150°C	
Maximum Junction Temperature (CERDIP Package)	175°C	
Maximum Storage Temperature Range	-65°C to 150°C	
Maximum Lead Temperature (Soldering 10s Max)	300°C	

## Analog Electrical Specifications $V_+ = +5V$ , $V_- = -5V$ , $GND = 0V$ , $T_A = 25^\circ C$ , $f_{CLK} = 3.58MHz$ , Unless Otherwise Specified

PARAMETER	TEST CONDITIONS	MIN	TYP	MAX	UNIT
<b>SYSTEM PERFORMANCE</b>					
Oscillator Output Current					
High, $O_{OH}$	$V_{OUT} = 2.5V$	-	1	-	mA
Low, $O_{OL}$	$V_{OUT} = 2.5V$	-	1.5	-	mA
Buffered Oscillator Output Current					
High, $BO_{OH}$	$V_{OUT} = 2.5V$	-	2	-	mA
Low, $BO_{OL}$	$V_{OUT} = 2.5V$	-	5	-	mA
Zero Input Reading	$V_{IN} = 0.0000V$ , $V_{REF} = 204.8mV$	-0000	$\pm 0000$	+0000	Counts
Ratiometric Error	$V_{IN} = V_{REF}$ , $V_{REF} = 204.8mV$ (Note 7)	-3	-	0	Counts
Non-Linearity	Full Scale = 409.6mV to 2.048mV Maximum Deviation from Best Straight Line Fit, Over Full Operating Temperature Range (Notes 4 and 6)	-1	$\pm 0.2$	+1	Counts
Rollover Error	Full Scale = 409.6mV to 2.048V Difference in Reading for Equal Positive and Negative Inputs Near Full Scale (Notes 5 and 6), $R_1 = 0\Omega$	-1	$\pm 0.2$	+1	Counts
Linearity	Full-Scale = 200mV or Full Scale = 2V Maximum Deviation from Best Straight Line Fit (Note 4)	-	$\pm 0.2$	$\pm 1$	Counts
Common Mode Rejection Ratio, CMRR	$V_{CM} = \pm 1V$ , $V_{IN} = 0V$ , Full Scale = 409.6mV	-	50	-	$\mu V/V$
Input Common Mode Range, VCMR	Input HI, Input LO, Common (Note 4)	(V-) +2.0	-	(V+) -2.0	V
Noise, eN	$V_{IN} = 0V$ , Full-Scale = 409.6mV (Peak-to-Peak Value Not Exceeded 95% of Time)	-	15	-	$\mu V$
Leakage Current Input, $I_{ILK}$	$V_{IN} = 0V$ , All Devices at 25°C (Note 4)	-	1	10	pA
ICL7109CPL	0°C to 70°C (Note 4)	-	20	100	pA
ICL7109IDL	-25°C to 85°C (Note 4)	-	100	250	pA
ICL7109MDL	-55°C to 125°C	-	2	100	nA
Zero Reading Drift	$V_{IN} = 0V$ , $R_1 = 0\Omega$ (Note 4)	-	0.2	1	$\mu V/^\circ C$

# ICL7109

**Analog Electrical Specifications**  $V_+ = +5V$ ,  $V_- = -5V$ ,  $GND = 0V$ ,  $T_A = 25^\circ C$ ,  $f_{CLK} = 3.58MHz$ ,  
Unless Otherwise Specified (Continued)

PARAMETER	TEST CONDITIONS	MIN	TYP	MAX	UNIT
Scale Factor Temperature Coefficient	$V_{IN} = 408.9mV = > 7770_8$ Reading Ext. Ref. $0ppm/^\circ C$ (Note 4)	-	1	5	$ppm/^\circ C$
<b>REFERENCE VOLTAGE</b>					
Ref Out Voltage, $V_{REF}$	Referred to $V_+$ , $25k\Omega$ Between $V_+$ and REF OUT	-2.4	-2.8	-3.2	V
Ref Out Temperature Coefficient	$25k\Omega$ Between $V_+$ and REF OUT (Note 4)	-	80	-	$ppm/^\circ C$
<b>POWER SUPPLY CHARACTERISTICS</b>					
Supply Current $V_+$ to GND, $I_+$	$V_{IN} = 0V$ , Crystal Osc 3.58MHz Test Circuit	-	700	1500	$\mu A$
Supply Current $V_+$ to $V_-$ , $I_{SUPP}$	Pins 2 - 21, 25, 26, 27, 29; Open	-	700	1500	$\mu A$

**Digital Electrical Specifications**  $V_+ = +5V$ ,  $V_- = -5V$ ,  $GND = 0V$ ,  $T_A = 25^\circ C$ , Unless Otherwise Specified

PARAMETER	TEST CONDITIONS	MIN	TYP	MAX	UNIT
<b>DIGITAL OUTPUTS</b>					
Output High Voltage, $V_{OH}$	$I_{OUT} = 100\mu A$ Pins 2 - 16, 18, 19, 20	3.5	4.3	-	V
Output Low Voltage, $V_{OL}$	$I_{OUT} = 1.6mA$ Pins 2 - 16, 18, 19, 20	-	$\pm 0.20$	$\pm 0.40$	V
Output Leakage Current	Pins 3 - 16 High Impedance	-	$\pm 0.01$	$\pm 1$	$\mu A$
Control I/O Pullup Current	Pins 18, 19, 20 $V_{OUT} = V_+ - 3V$ MODE Input at GND (Note 4)	-	5	-	$\mu A$
Control I/O Loading	$\overline{HBEN}$ Pin 19 $\overline{LBEN}$ Pin 18 (Note 4)	-	-	50	pF
<b>DIGITAL INPUTS</b>					
Input High Voltage, $V_{IH}$	Pins 18 - 21, 26, 27 Referred to GND	3.0	-	-	V
Input Low Voltage, $V_{IL}$	Pins 18 - 21, 26, 27 Referred to GND	-	-	1	V
Input Pull-Up Current	Pins 26, 27 $V_{OUT} = (V_+) - 3V$	-	5	-	$\mu A$
Input Pull-Up Current	Pins 17, 24 $V_{OUT} = (V_+) - 3V$	-	25	-	$\mu A$
Input Pull-Down Current	Pin 21 $V_{OUT} = GND + 3V$	-	5	-	$\mu A$
<b>TIMING CHARACTERISTICS</b>					
MODE Input Pulse Width, $t_W$	(Note 4)	50	-	-	ns

**NOTES:**

1. Input voltages may exceed the supply voltages provided the input current is limited to  $\pm 100\mu A$ .
2. Due to the SCR structure inherent in the process used to fabricate these devices, connecting any digital inputs or outputs to voltages greater than  $V_+$  or less than GND may cause destructive device latchup. For this reason it is recommended that no inputs from sources other than the same power supply be applied to the ICL7109 before its power supply is established, and that in multiple supply systems the supply to the ICL7109 be activated first.
3. This limit refers to that of the package and will not be obtained during normal operation.
4. This parameter is not production tested, but is guaranteed by design.
5. Roll-over error for  $T_A = -55^\circ C$  to  $125^\circ C$  is  $\pm 10$  counts (Max).
6. A full scale voltage of 2.048V is used because a full scale voltage of 4.096V exceeds the devices Common Mode Voltage Range.
7. For CERDIP package the Ratiometric error can be -4 (Min).

# ICL7109

## Pin Descriptions

PIN	SYMBOL	DESCRIPTION	
1	GND	Digital Ground, 0V. Ground return for all digital logic.	
2	STATUS	Output High during integrate and deintegrate until data is latched. Output Low when analog section is in Auto-Zero configuration.	
3	POL	Polarity - HI for positive input.	Three-State Output Data Bits
4	OR	Overrange - HI if overranged.	Three-State Output Data Bits
5	B12	Bit 12	(Most Significant Bit) Three-State Output Data Bits
6	B11	Bit 11	High = True Three-State Output Data Bits
7	B10	Bit 10	High = True Three-State Output Data Bits
8	B9	Bit 9	High = True Three-State Output Data Bits
9	B8	Bit 8	High = True Three-State Output Data Bits
10	B7	Bit 7	High = True Three-State Output Data Bits
11	B6	Bit 6	High = True Three-State Output Data Bits
12	B5	Bit 5	High = True Three-State Output Data Bits
13	B4	Bit 4	High = True Three-State Output Data Bits
14	B3	Bit 3	High = True Three-State Output Data Bits
15	B2	Bit 2	High = True Three-State Output Data Bits
16	B1	Bit 1	(Least Significant Bit) Three-State Output Data Bits
17	TEST	Input High - Normal Operation. Input Low - Forces all bit outputs high. Note: This input is used for test purposes only. Tie high if not used.	
18	$\overline{\text{LBEN}}$	Low Byte Enable - With Mode (Pin 21) low, and $\overline{\text{CE/LOAD}}$ (Pin 20) low, taking this pin low activates low order byte outputs B1 through B8. With Mode (Pin 21) high, this pin serves as a low byte flag output used in handshake mode. See Figures 7, 8, 9.	
19	$\overline{\text{HBEN}}$	High Byte Enable - With Mode (Pin 21) low, and $\overline{\text{CE/LOAD}}$ (Pin 20) low, taking this pin low activates high order byte outputs B9 through B12, POL, OR. With Mode (Pin 21) high, this pin serves as a high byte flag output used in handshake mode. See Figures 7, 8, 9.	
20	$\overline{\text{CE/LOAD}}$	Chip Enable Load - With Mode (Pin 21) low, $\overline{\text{CE/LOAD}}$ serves as a master output enable. When high, B1 through B12, POL, OR outputs are disabled. With Mode (Pin 21) high, this pin serves as a load strobe used in handshake mode. See Figures 7, 8, 9.	
21	MODE	Input Low - Direct output mode where $\overline{\text{CE/LOAD}}$ (Pin 20), $\overline{\text{HBEN}}$ (Pin 19) and $\overline{\text{LBEN}}$ (Pin 18) act as inputs directly controlling byte outputs. Input Pulsed High - Causes immediate entry into handshake mode and output of data as in Figure 9. Input High - Enables $\overline{\text{CE/LOAD}}$ (Pin 20), $\overline{\text{HBEN}}$ (Pin 19), and $\overline{\text{LBEN}}$ (Pin 18) as outputs, handshake mode will be entered and data output as in Figures 7 and 8 at conversion completion.	
22	OSC IN	Oscillator Input	
23	OSC OUT	Oscillator Output	

## ICL7109

### **Pin Descriptions** (Continued)

PIN	SYMBOL	DESCRIPTION
24	OSC SEL	Oscillator Select - Input high configures OSC IN, OSC OUT, BUF OSC OUT as RC oscillator - clock will be same phase and duty cycle as BUF OSC OUT. Input low configures OSC IN, OSC OUT for crystal oscillator - clock frequency will be 1/58 of frequency at BUF OSC OUT.
25	BUF OSC OUT	Buffered Oscillator Output
26	RUN/HOLD	Input High - Conversions continuously performed every 8192 clock pulses. Input Low - Conversion in progress completed, converter will stop in Auto-Zero 7 counts before integrate.
27	SEND	Input - Used in handshake mode to indicate ability of an external device to accept data. Connect to +5V if not used.
28	V-	Analog Negative Supply - Nominally -5V with respect to GND (Pin 1).
29	REF OUT	Reference Voltage Output - Nominally 2.8V down from V+ (Pin 40).
30	BUFFER	Buffer Amplifier Output.
31	AUTO-ZERO	Auto-Zero Node - Inside foil of C <sub>AZ</sub> .
32	INTEGRATOR	Integrator Output - Outside foil of C <sub>INT</sub> .
33	COMMON	Analog Common - System is Auto-Zeroed to COMMON.
34	INPUT LO	Differential Input Low Side.
35	INPUT HI	Differential Input High Side.
36	REF IN +	Differential Reference Input Positive.
37	REF CAP +	Reference Capacitor Positive.
38	REF CAP-	Reference Capacitor Negative.
39	REF IN-	Differential Reference Input Negative.
40	V+	Positive Supply Voltage - Nominally +5V with respect to GND (Pin 1).

NOTE: All digital levels are positive true.

**Design Information Summary Sheet**

• **OSCILLATOR FREQUENCY**

$f_{OSC} = 0.45/RC$   
 $C_{OSC} > 50pF$ ;  $R_{OSC} > 50k\Omega$   
 $f_{OSC} (Typ) = 60kHz$   
 or  
 $f_{OSC} (Typ) = 3.58MHz$  Crystal

• **OSCILLATOR PERIOD**

$t_{OSC} = RC/0.45$   
 $t_{OSC} = 1/3.58MHz$  (Crystal)

• **INTEGRATION CLOCK FREQUENCY**

$f_{CLOCK} = f_{OSC}$  (RC Mode)  
 $f_{CLOCK} = f_{OSC}/58$  (Crystal)  
 $t_{CLOCK} = 1/f_{CLOCK}$

• **INTEGRATION PERIOD**

$t_{INT} = 2048 \times t_{CLOCK}$

• **60/50Hz REJECTION CRITERION**

$t_{INT}/t_{60Hz}$  or  $t_{INT}/t_{50Hz} = \text{Integer}$

• **OPTIMUM INTEGRATION CURRENT**

$I_{INT} = 20\mu A$

• **FULL-SCALE ANALOG INPUT VOLTAGE**

$V_{INFS}$  Typically = 200mV or 2V

• **INTEGRATE RESISTOR**

$$R_{INT} = \frac{V_{INFS}}{I_{INT}}$$

• **INTEGRATE CAPACITOR**

$$C_{INT} = \frac{(t_{INT})(I_{INT})}{V_{INT}}$$

• **INTEGRATOR OUTPUT VOLTAGE SWING**

$$V_{INT} = \frac{(t_{INT})(I_{INT})}{C_{INT}}$$

•  **$V_{INT}$  MAXIMUM SWING**

$(V- + 0.5V) < V_{INT} < (V+ - 0.5V)$   
 $V_{INT} (Typ) = 2V$

• **DISPLAY COUNT**

$$COUNT = 2048 \times \frac{V_{IN}}{V_{REF}}$$

• **CONVERSION CYCLE**

$t_{CYC} = t_{CLOCK} \times 8192$   
 (In Free Run Mode, Run/ $\overline{HOLD}$  = 1)  
 when  $f_{CLOCK} = 60kHz$ ,  $t_{CYC} = 133ms$

• **COMMON MODE INPUT VOLTAGE**

$(V- + 2.0V) < V_{IN} < (V+ - 2V)$

• **AUTO-ZERO CAPACITOR**

$0.01\mu F < C_{AZ} < 1\mu F$

• **REFERENCE CAPACITOR**

$0.1\mu F < C_{REF} < 1\mu F$

•  **$V_{REF}$**

Biased between  $V+$  and  $V-$   
 $V_{REF} \equiv V+ - 2.8V$   
 Regulation lost when  $V+$  to  $V- \leq 6.4V$ .  
 If  $V_{REF}$  is not used, float output pin.

• **POWER SUPPLY: DUAL  $\pm 5.0V$**

$V+ = +5V$  to GND  
 $V- = -5V$  to GND

• **OUTPUT TYPE**

Binary Amplitude with Polarity and Overrange Bits  
 Tips: Always tie TEST pin HIGH.  
 Don't leave any inputs floating.

# ICL7109

## Typical Integrator Amplifier Output Waveform (INT Pin)

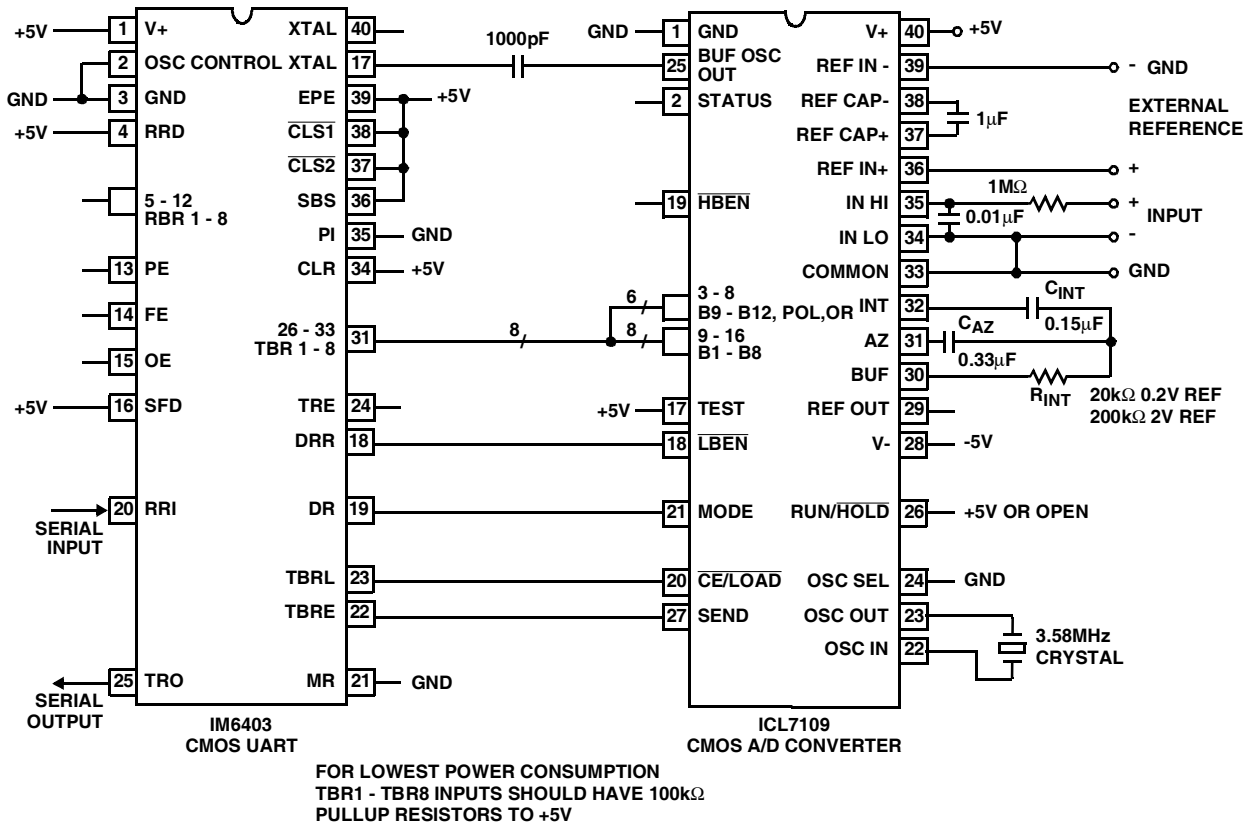
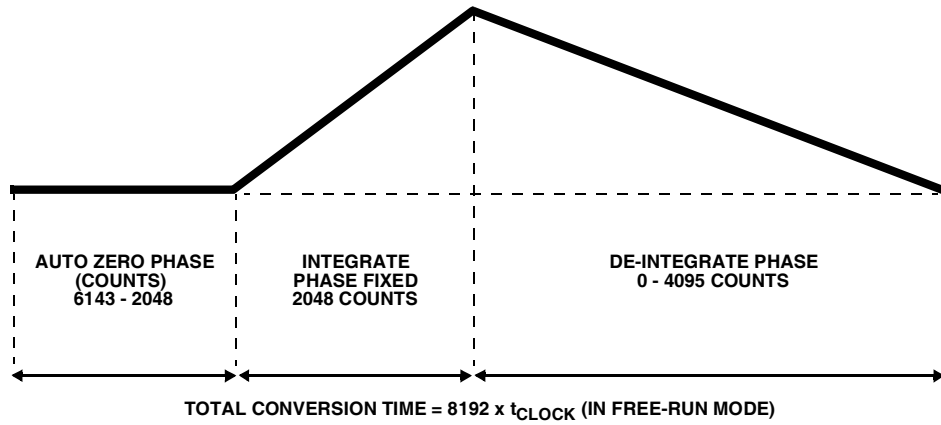

FIGURE 1A. TYPICAL CONNECTION DIAGRAM UART INTERFACE-TO TRANSMIT LATEST RESULT, SEND ANY WORD TO UART



**De-Integrate Phase**

The final phase is de-integrate, or reference integrate. Input low is internally connected to analog COMMON and input high is connected across the previously charged (during auto-zero) reference capacitor. Circuitry within the chip ensures that the capacitor will be connected with the correct polarity to cause the integrator output to return to zero crossing (established in Auto-Zero) with a fixed slope. The time required for the output to return to zero is proportional to the input signal.

**Differential Input**

The input can accept differential voltages anywhere within the common mode range of the input amplifier, or specifically from 1V below the positive supply to 1.5V above the negative supply. In this range, the system has a CMRR of 86dB typical. However, care must be exercised to assure the integrator output does not saturate. A worst case condition would be a large positive common mode voltage with a near full-scale negative differential input voltage. The negative input signal drives the integrator positive when most of its swing has been used up by the positive common mode voltage. For these critical applications the integrator output swing can be reduced to less than the recommended 4V full scale swing with little loss of accuracy. The integrator output can swing to within 0.3V of either supply without loss of linearity.

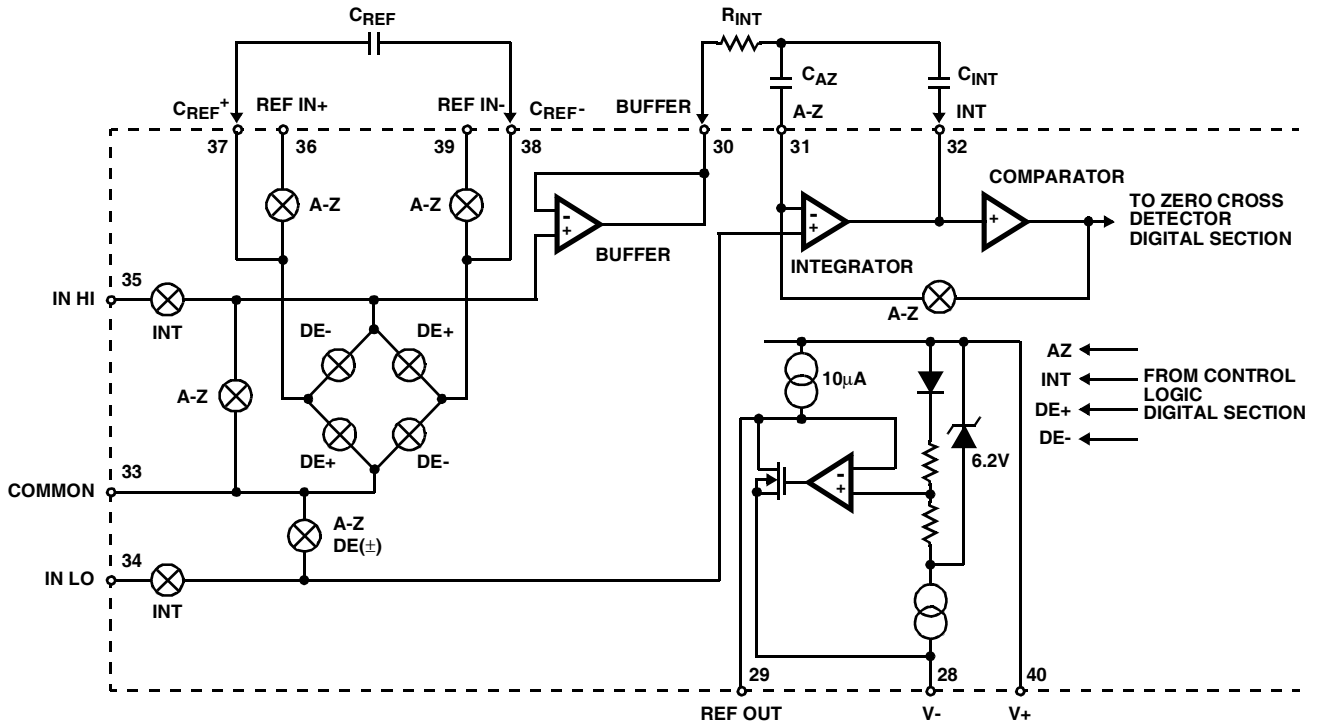

FIGURE 2. ANALOG SECTION OF ICL7109

The ICL7109 has, however, been optimized for operation with analog common near digital ground. With power supplies of +5V and -5V, this allows a 4V full scale integrator swing positive or negative thus maximizing the performance of the analog section.

**Differential Reference**

The reference voltage can be generated anywhere within the power supply voltage of the converter. The main source of common mode error is a roll-over voltage caused by the reference capacitor losing or gaining charge to stray capacity on its nodes. If there is a large common mode voltage, the reference capacitor can gain charge (increase voltage) when called up to deintegrate a positive signal but lose charge (decrease voltage) when called up to deintegrate a negative input signal. This difference in reference for positive or negative input voltage will give a roll-over error. However, by

selecting the reference capacitor large enough in comparison to the stray capacitance, this error can be held to less than 0.5 count worst case. (See Component Value Selection.)

The roll-over error from these sources is minimized by having the reference common mode voltage near or at analog COMMON.

**Component Value Selection**

For optimum performance of the analog section, care must be taken in the selection of values for the integrator capacitor and resistor, auto-zero capacitor, reference voltage, and conversion rate. These values must be chosen to suit the particular application.

The most important consideration is that the integrator output swing (for full-scale input) be as large as possible. For example, with ±5V supplies and COMMON connected to

Teflon™ is a trademark of DuPont Corporation

GND, the normal integrator output swing at full scale is  $\pm 4V$ . Since the integrator output can go to 0.3V from either supply without significantly affecting linearity, a 4V integrator output swing allows 0.7V for variations in output swing due to component value and oscillator tolerances. With  $\pm 5V$  supplies and a common mode range of  $\pm 1V$  required, the component values should be selected to provide  $\pm 3V$  integrator output swing. Noise and roll-over will be slightly worse than in the  $\pm 4V$  case. For larger common mode voltage ranges, the integrator output swing must be reduced further. This will increase both noise and roll-over errors. To improve the performance, supplies of  $\pm 6V$  may be used.

#### Integrating Resistor

Both the buffer amplifier and the integrator have a class A output stage with  $100\mu A$  of quiescent current. They supply  $20\mu A$  of drive current with negligible nonlinearity. The integrating resistor should be large enough to remain in this very linear region over the input voltage range, but small enough that undue leakage requirements are not placed on the PC board. For 409.6mV full-scale,  $200k\Omega$  is near optimum and similarly a  $20k\Omega$  for a 409.6mV scale. For other values of full scale voltage,  $R_{INT}$  should be chosen by the relation :

$$R_{INT} = \frac{\text{full scale voltage}}{20\mu A}$$

#### Integrating Capacitor

The integrating capacitor  $C_{INT}$  should be selected to give the maximum voltage swing that ensures tolerance build-up will not saturate the integrator swing (approximately 0.3V from either supply). For the ICL7109 with  $\pm 5V$  supplies and analog common connected to GND, a  $\pm 3.5V$  to  $\pm 4V$  integrator output swing is nominal. For  $7^{1/2}$  conversions per second (61.72kHz clock frequency) as provided by the crystal oscillator, nominal values for  $C_{INT}$  and  $C_{AZ}$  are  $0.15\mu F$  and  $0.33\mu F$ , respectively. If different clock frequencies are used, these values should be changed to maintain the integrator output swing. In general, the value  $C_{INT}$  is given by:

$$C_{INT} = \frac{(2048 \times \text{clock period})(20\mu A)}{\text{integrator output voltage swing}}$$

An additional requirement of the integrating capacitor is that it have low dielectric absorption to prevent roll-over errors. While other types of capacitors are adequate for this application, polypropylene capacitors give undetectable errors at The integrating capacitor should have a low dielectric absorption to prevent roll-over errors. While other types may be adequate for this application, polypropylene capacitors give undetectable errors at reasonable cost up to  $85^{\circ}C$ . Teflon™ capacitors are recommended for the military temperature range. While their dielectric absorption characteristics vary somewhat from unit to unit, selected devices should give less than 0.5 count of error due to dielectric absorption.

#### Auto-Zero Capacitor

The size of the auto-zero capacitor has some influence on the noise of the system: a smaller physical size and a larger capacitance value lower the overall system noise. However,  $C_{AZ}$  cannot be increased without limits since it, in parallel

with the integrating capacitor forms an R-C time constant that determines the speed of recovery from overloads and the error that exists at the end of an auto-zero cycle. For 409.6mV full scale where noise is very important and the integrating resistor small, a value of  $C_{AZ}$  twice  $C_{INT}$  is optimum. Similarly for 4.096V full scale where recovery is more important than noise, a value of  $C_{AZ}$  equal to half of  $C_{INT}$  is recommended.

For optimal rejection of stray pickup, the outer foil of  $C_{AZ}$  should be connected to the R-C summing junction and the inner foil to pin 31. Similarly the outer foil of  $C_{INT}$  should be connected to pin 32 and the inner foil to the R-C summing junction. Teflon, or equivalent, capacitors are recommended above  $85^{\circ}C$  for their low leakage characteristics.

#### Reference Capacitor

A  $1\mu F$  capacitor gives good results in most applications. However, where a large reference common mode voltage exists (i.e., the reference low is not at analog common) and a 409.6mV scale is used, a large value is required to prevent roll-over error. Generally  $10\mu F$  will hold the roll-over error to 0.5 count in this instance. Again, Teflon, or equivalent capacitors should be used for temperatures above  $85^{\circ}C$  for their low leakage characteristics.

**Reference Voltage**

The analog input required to generate a full scale output of 4096 counts is  $V_{IN} = 2V_{REF}$ . For normalized scale, a reference of 2.048V should be used for a 4.096V full scale, and 204.8mV should be used for a 0.4096V full scale. However, in many applications where the A/D is sensing the output of a transducer, there will exist a scale factor other than unity between the absolute output voltage to be measured and a desired digital output. For instance, in a weighing system, the designer might like to have a full scale reading when the voltage from the transducer is 0.682V. Instead of driving the input down to 409.6mV, the input voltage should be measured directly and a reference voltage of 0.341V should be used. Suitable values for integrating resistor and capacitor are 33kΩ and 0.15μF. This avoids a divider on the input. Another advantage of this system occurs when a zero reading is desired for non-zero input. Temperature and weight measurements with an offset or tare are examples. The offset may be introduced by connecting the voltage output of the transducer between common and analog high, and the offset voltage between common and analog low, observing polarities carefully. However, in processor-based systems using the ICL7109, it may be more efficient to perform this type of scaling or tare subtraction digitally using software.

**Reference Sources**

The stability of the reference voltage is a major factor in the overall absolute accuracy of the converter. The resolution of the ICL7109 at 12 bits is one part in 4096, or 244ppm. Thus if the reference has a temperature coefficient of 80ppm/°C (onboard reference) a temperature difference of 3°C will introduce a one-bit absolute error.

For this reason, it is recommended that an external high-quality reference be used where the ambient temperature is not controlled or where high-accuracy absolute measure-

ments are being made.

The ICL7109 provides a REFERENCE OUTPUT (Pin 29) which may be used with a resistive divider to generate a suitable reference voltage. This output will sink up to about 20mA without significant variation in output voltage, and is provided with a pullup bias device which sources about 10μA. The output voltage is nominally 2.8V below V+, and has a temperature coefficient of ±80ppm/°C (Typ). When using the onboard reference, REF OUT (Pin 29) should be connected to REF- (Pin 39), and REF+ should be connected to the wiper of a precision potentiometer between REF OUT and V+. The circuit for a 204.8mV reference is shown in the test circuit. For a 2.048mV reference, the fixed resistor should be removed, and a 25kΩ precision potentiometer between REF OUT and V+ should be used.

Note that if Pins 29 and 39 are tied together and Pins 39 and 40 accidentally shorted (e.g., during testing), the reference supply will sink enough current to destroy the device. This can be avoided by placing a 1kΩ resistor in series with Pin 39.

**Detailed Description**

**Digital Section**

The digital section includes the clock oscillator and scaling circuit, a 12-bit binary counter with output latches and TTL-compatible three-state output drivers, polarity, over-range and control logic, and UART handshake logic, as shown in Figure 4.

Throughout this description, logic levels will be referred to as "low" or "high". The actual logic levels are defined in the Electrical Specifications Table. For minimum power consumption, all inputs should swing from GND (low) to V+ (high). Inputs driven from TTL gates should have 3-5kΩ pullup resistors

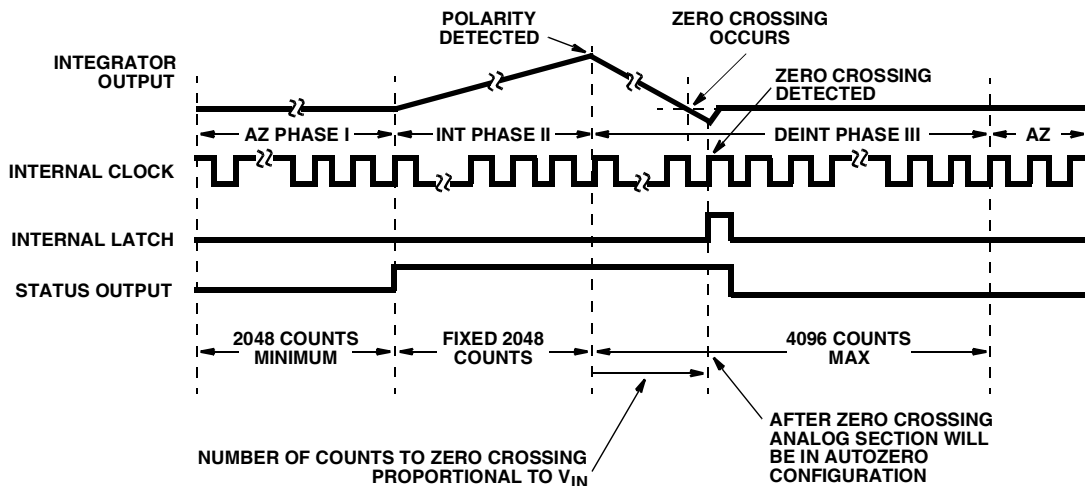

FIGURE 3. CONVERSION TIMING (RUN/HOLD PIN HIGH)

**MODE Input**

The MODE input is used to control the output mode of the



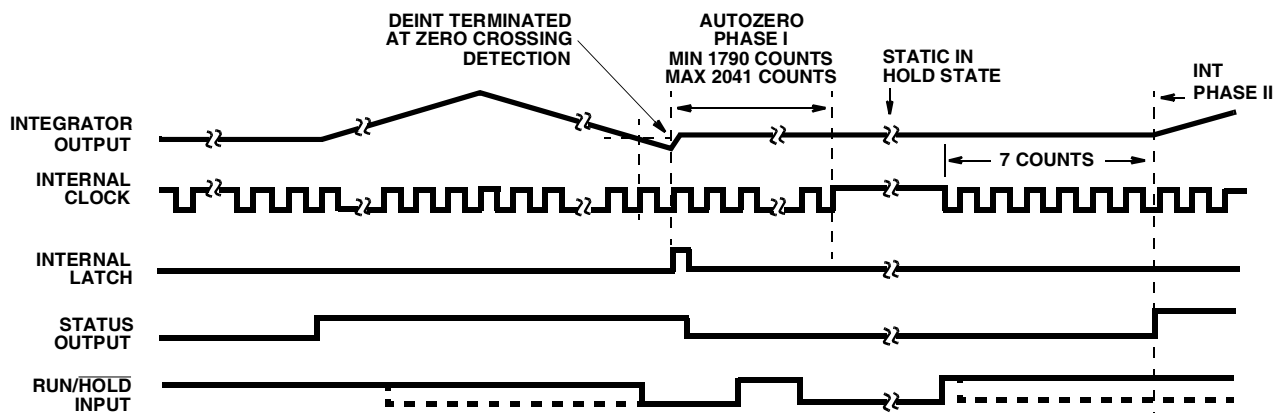

FIGURE 5. RUN/HOLD OPERATION

If RUN/HOLD goes low at any time during Deintegrate (Phase III) after the zero crossing has occurred, the circuit will immediately terminate Deintegrate and jump to Auto-Zero. This feature can be used to eliminate the time spent in Deintegrate after the zero-crossing. If RUN/HOLD stays or goes low, the converter will ensure minimum Auto-Zero time, and then wait in Auto-Zero until the RUN/HOLD input goes high. The converter will begin the Integrate (Phase II) portion of the next conversion (and the STATUS output will go high) seven clock periods after the high level is detected at RUN/HOLD. See Figure 5 for details.

Using the RUN/HOLD input in this manner allows an easy "convert on demand" interface to be used. The converter may be held at idle in auto-zero with RUN/HOLD low. When RUN/HOLD goes high the conversion is started, and when the STATUS output goes low the new data is valid (or transferred to the UART; see Handshake Mode). RUN/HOLD may now be taken low which terminates deintegrate and ensures a minimum Auto-Zero time before the next conversion.

Alternately, RUN/HOLD can be used to minimize conversion time by ensuring that it goes low during Deintegrate, after zero crossing, and goes high after the hold point is reached. The required activity on the RUN/HOLD input can be provided by connecting it to the Buffered Oscillator Output. In this mode the conversion time is dependent on the input value measured. Also refer to Intersil Application Note AN032 for a discussion of the effects this will have on Auto-Zero performance.

If the RUN/HOLD input goes low and stays low during Auto-Zero (Phase I), the converter will simply stop at the end of Auto-Zero and wait for RUN/HOLD to go high. As above, Integrate (Phase II) begins seven clock periods after the high level is detected.

**Direct Mode**

When the MODE pin is left at a low level, the data outputs (bits 1 through 8 low order byte, bits 9 through 12, polarity and over-range high order byte) are accessible under control of the byte and chip enable terminals as inputs. These three inputs are all active low, and are provided with pullup resistors

to ensure an inactive high level when left open. When the chip enable input is low, taking a byte enable input low will allow the outputs of that byte to become active (three-stated on). This allows a variety of parallel data accessing techniques to be used, as shown in the section entitled "Interfacing." The timing requirements for these outputs are shown in Figure 6 and Table 1.

It should be noted that these control inputs are asynchronous with respect to the converter clock - the data may be accessed at any time. Thus it is possible to access the latches while they are being updated, which could lead to erroneous data. Synchronizing the access of the latches with the conversion cycle by monitoring the STATUS output will prevent this. Data is never updated while STATUS is low.

TABLE 1. DIRECT MODE TIMING REQUIREMENTS  
(See Note 4 of Electrical Specifications)

DESCRIPTION	SYMBOL	MIN	TYP	MAX	UNITS
Byte Enable Width	t <sub>BEA</sub>	350	220	-	ns
Data Access Time from Byte Enable	t <sub>DAB</sub>	-	210	350	ns
Data Hold Time from Byte Enable	t <sub>DHB</sub>	-	150	300	ns
Chip Enable Width	t <sub>CEA</sub>	400	260	-	ns
Data Access Time from Chip Enable	t <sub>DAC</sub>	-	260	400	ns
Data Hold Time from Chip Enable	t <sub>DHC</sub>	-	240	400	ns

**TABLE 1. DIRECT MODE TIMING REQUIREMENTS**  
(See Note 4 of Electrical Specifications)

DESCRIPTION	SYMBOL	MIN	TYP	MAX	UNITS
-------------	--------	-----	-----	-----	-------

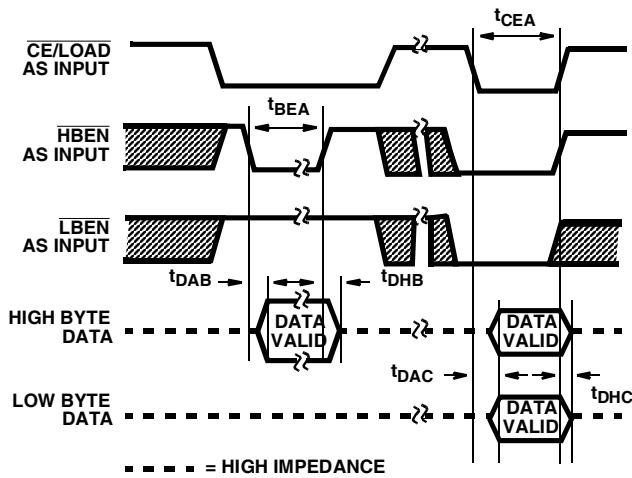

**FIGURE 6. DIRECT MODE OUTPUT TIMING**

**Handshake Mode**

The handshake output mode is provided as an alternative means of interfacing the ICL7109 to digital systems where the A/D converter becomes active in controlling the flow of data instead of passively responding to chip and byte enable inputs. This mode is specifically designed to allow a direct interface between the ICL7109 and industry-standard UARTs (such as the Intersil IM6402/3) with no external logic required. When triggered into the handshake mode, the ICL7109 provides all the control and flag signals necessary to sequentially transfer two bytes of data into the UART and initiate their transmission in serial form. This greatly eases the task and reduces the cost of designing remote data acquisition stations using serial data transmission.

Entry into the handshake mode is controlled by the MODE pin. When the MODE terminal is held high, the ICL7109 will enter the handshake mode after new data has been stored in the output latches at the end of a conversion (See Figures 7 and 8). The MODE terminal may also be used to trigger entry into the handshake mode on demand. At any time during the conversion cycle, the low to high transition of a short pulse at the MODE input will cause immediate entry into the handshake mode. If this pulse occurs while new data is being stored, the entry into handshake mode is delayed until the data is stable. While the converter is in the handshake mode, the MODE input is ignored, and although conversions will still be performed, data updating will be inhibited (See Figure 9) until the converter completes the output cycle and clears the handshake mode.

When the converter enters the handshake mode, or when the MODE input is high, the chip and byte enable terminals become TTL-compatible outputs which provide the control

signals for the output cycle (See Figures 7, 8, and 9).

In handshake mode, the SEND input is used by the converter as an indication of the ability of the receiving device (such as a UART) to accept data.

Figure 7 shows the sequence of the output cycle with SEND held high. The handshake mode (Internal MODE high) is entered after the data latch pulse, and since MODE remains high the  $\overline{\text{CE/LOAD}}$ ,  $\overline{\text{LBEN}}$  and  $\overline{\text{HBEN}}$  terminals are active as outputs. The high level at the SEND input is sensed on the same high to low internal clock edge that terminates the data latch pulse. On the next low to high internal clock edge the  $\overline{\text{CE/LOAD}}$  and the  $\overline{\text{HBEN}}$  outputs assume a low level, and the high-order byte (Bits 9 through 12, POL, and OR) outputs are enabled. The  $\overline{\text{CE/LOAD}}$  output remains low for one full internal clock period only, the data outputs remain active for  $1\frac{1}{2}$  internal clock periods, and the high byte enable remains low for two clock periods. Thus the  $\overline{\text{CE/LOAD}}$  output low level or low to high edge may be used as a synchronizing signal to ensure valid data, and the byte enable as an output may be used as a byte identification flag. With SEND remaining high the converter completes the output cycle using  $\overline{\text{CE/LOAD}}$  and  $\overline{\text{LBEN}}$  while the low order byte outputs (bits 1 through 8) are activated. The handshake mode is terminated when both bytes are sent.

Figure 8 shows an output sequence where the SEND input is used to delay portions of the sequence, or handshake to ensure correct data transfer. This timing diagram shows the relationships that occur using an industry-standard IM6402/3 CMOS UART to interface to serial data channels. In this interface, the SEND input to the ICL7109 is driven by the TBRE (Transmitter Buffer Register Empty) output of the UART, and the  $\overline{\text{CE/LOAD}}$  terminal of the ICL7109 drives the TBRL (Transmitter Buffer Register Load) input to the UART. The data outputs are paralleled into the eight Transmitter Buffer Register inputs.

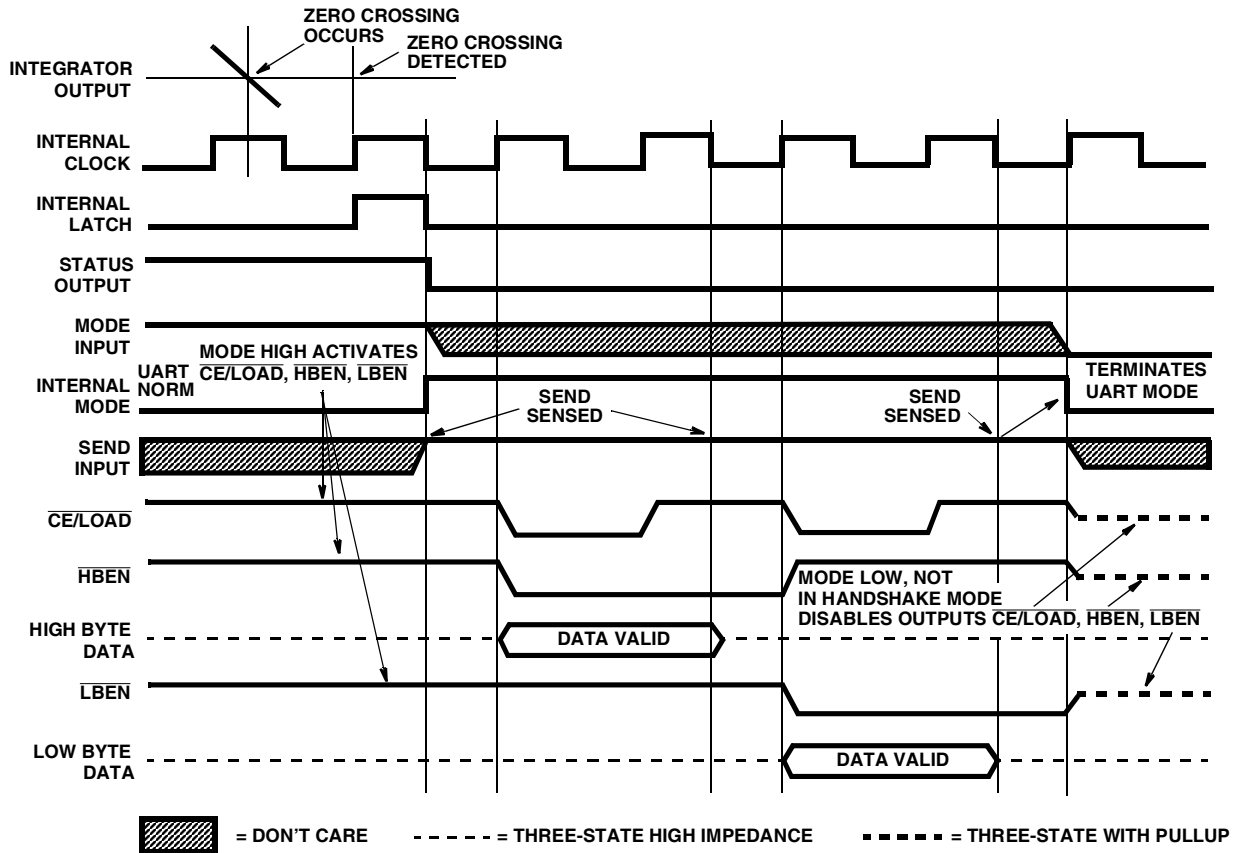

FIGURE 7. HANDSHAKE WITH SEND HELD HIGH

Assuming the UART Transmitter Buffer Register is empty, the SEND input will be high when the handshake mode is entered after new data is stored. The CE/LOAD and HBEN terminals will go low after SEND is sensed, and the high order byte outputs become active. When CE/LOAD goes high at the end of one clock period, the high order byte data is clocked into the UART Transmitter Buffer Register. The UART TBRE output will now go low, which halts the output cycle with the HBEN output low, and the high order byte outputs active. When the UART has transferred that data to the Transmitter Register and cleared the Transmitter Buffer Register, the TBRE returns high. On the next ICL7109 internal clock high to low edge, the high order byte outputs are disabled, and one-half internal clock later, the HBEN output returns high. At the same time, the CE/LOAD and LBEN outputs go low, and the low order byte outputs become active. Similarly, when the CE/LOAD returns high at the end of one clock period, the low order data is clocked into the UART Transmitter Buffer Register, and TBRE again goes low. When TBRE returns to a high it will be sensed on the next ICL7109 internal clock high to low edge, disabling the data outputs. One-half internal clock later, the handshake mode will be cleared, and the CE/LOAD, HBEN and LBEN terminals return high and stay inactive (as long as MODE stays high).

With the MODE input remaining high as in these examples, the converter will output the results of every conversion except those completed during a handshake operation. By triggering the converter into handshake mode with a low to

high edge on the MODE input, handshake output sequences may be performed on demand. Figure 9 shows a handshake output sequence triggered by such an edge. In addition, the SEND input is shown as being low when the converter enters handshake mode. In this case, the whole output sequence for the first (high order) byte is similar to the sequence for the second byte. This diagram also shows the output sequence taking longer than a conversion cycle. Note that the converter still makes conversions, with the STATUS output and RUN/HOLD input functioning normally. The only difference is that new data will not be latched when in handshake mode, and is therefore lost.

**Oscillator**

The ICL7109 is provided with a versatile three terminal oscillator to generate the internal clock. The oscillator may be overdriven, or may be operated with an RC network or crystal. The OSCILLATOR SELECT input changes the internal configuration of the oscillator to optimize it for RC or crystal operation.

When the OSCILLATOR SELECT input is high or left open (the input is provided with a pullup resistor), the oscillator is configured for RC operation, and the internal clock will be of the same frequency and phase as the signal at the BUFFERED OSCILLATOR OUTPUT. The resistor and capacitor should be connected as in Figure 10. The circuit will oscillate at a frequency given by  $f = 0.45/RC$ . A 100kΩ resistor is recommended for useful ranges of frequency. For optimum 60Hz line rejection, the capacitor value should be chosen

such that 2048 clock periods is close to an integral multiple of the 60Hz period (but should not be less than 50pF).

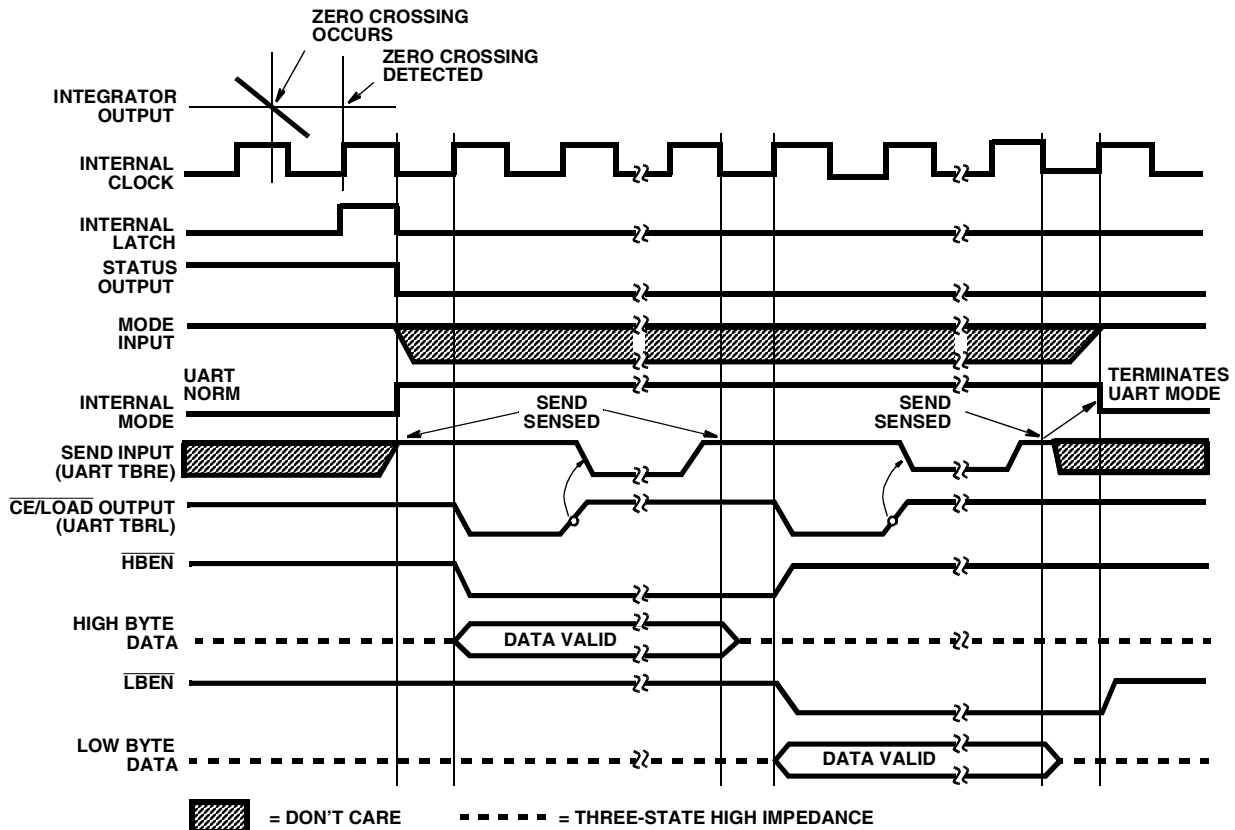

FIGURE 8. HANDSHAKE - TYPICAL UART INTERFACE TIMING

When the OSCILLATOR SELECT input is low a feedback device and output and input capacitors are added to the oscillator. In this configuration, as shown in Figure 11, the oscillator will operate with most crystals in the 1MHz to 5MHz range with no external components. Taking the OSCILLATOR SELECT input low also inserts a fixed ÷58 divider circuit between the BUFFERED OSCILLATOR OUTPUT and the internal clock. Using an inexpensive 3.58MHz TV crystal, this division ratio provides an integration time given by:

$$t_{INT} = (2048 \text{ clock periods}) \times (t_{CLOCK}) = 33.18\text{ms where:}$$

$$t_{CLOCK} = \frac{58}{3.58\text{MHZ}}$$

This time is very close to two 60Hz periods or 33ms. The error is less than one percent, which will give better than 40dB 60Hz rejection. The converter will operate reliably at conversion rates of up to 30 per second, which corresponds to a clock frequency of 245.8kHz.

If at any time the oscillator is to be overdriven, the overdriving signal should be applied at the OSCILLATOR INPUT, and the OSCILLATOR OUTPUT should be left open. The internal clock will be of the same frequency, duty cycle, and phase as the input signal when OSCILLATOR SELECT is left open. When OSCILLATOR SELECT is at GND, the clock will be a factor of 58 below the input frequency.

When using the ICL7109 with the IM6403 UART, it is

possible to use one 3.58MHz crystal for both devices. The BUFFERED OSCILLATOR OUTPUT of the ICL7109 may be used to drive the OSCILLATOR INPUT of the UART, saving the need for a second crystal. However, the BUFFERED OSCILLATOR OUTPUT does not have a great deal of drive capability, and when driving more than one slave device external buffering should be used.

**Test Input**

When the TEST input is taken to a level halfway between V+ and GND, the counter output latches are enabled, allowing the counter contents to be examined anytime.

When the RUN/HOLD is low and the TEST input is connected to GND, the counter outputs are all forced into the high state, and the internal clock is disabled. When the RUN/HOLD returns high and the TEST input returns to the 1/2 (V+ - GND) voltage (or to V+) and one clock is applied, all the counter outputs will be clocked to the low state. This allows easy testing of the counter and its outputs.

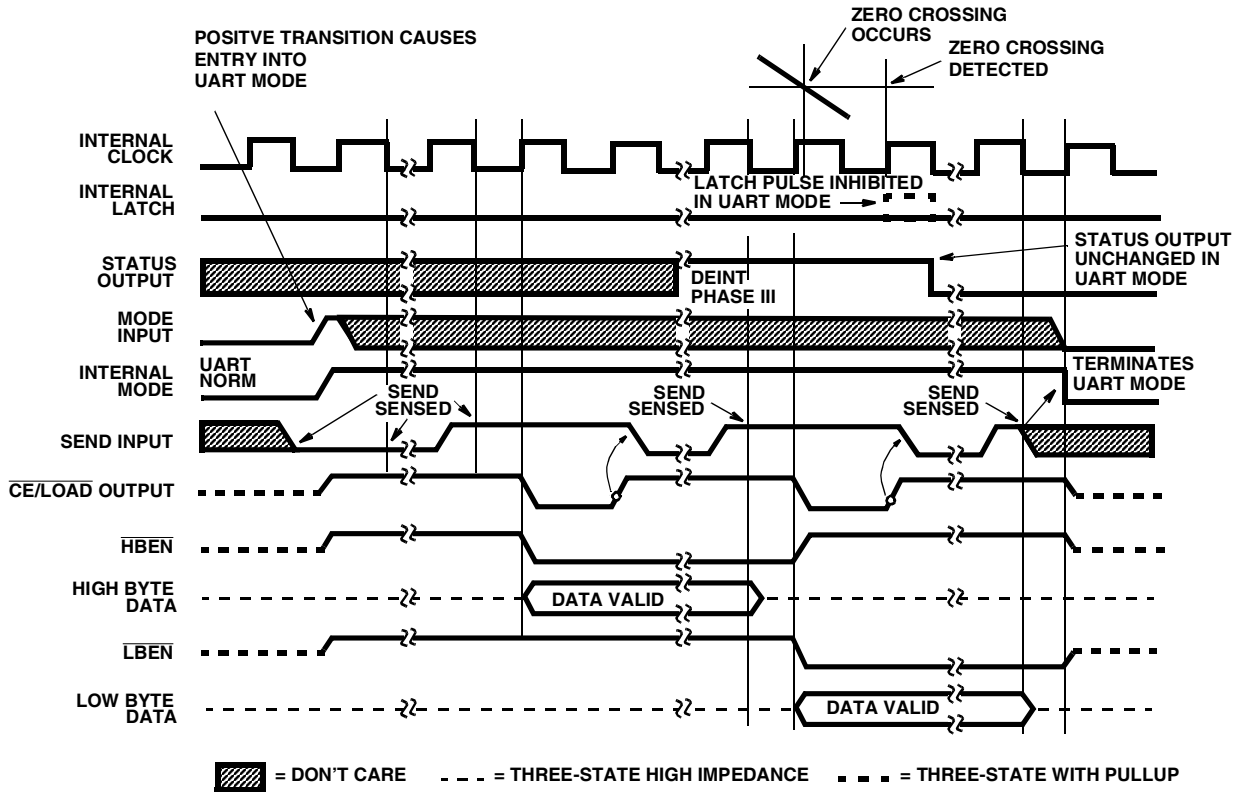

FIGURE 9. HANDSHAKE TRIGGERED BY MODE

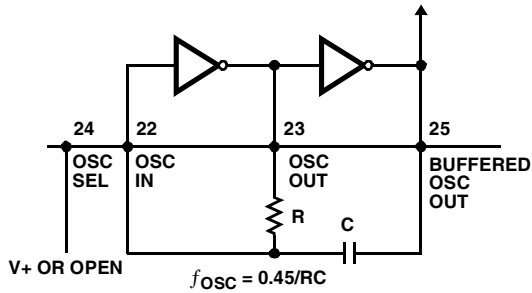

FIGURE 10. RC OSCILLATOR

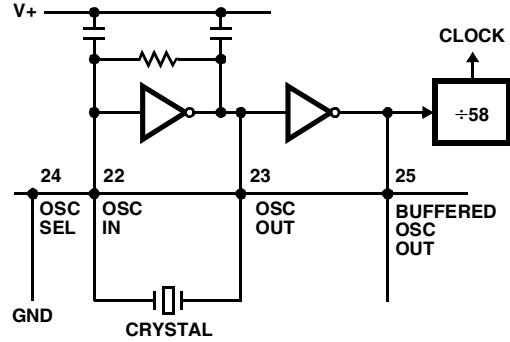

FIGURE 11. CRYSTAL OSCILLATOR

# ICL7109

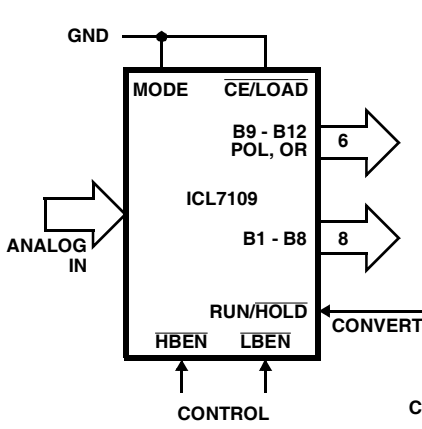

FIGURE 12A.

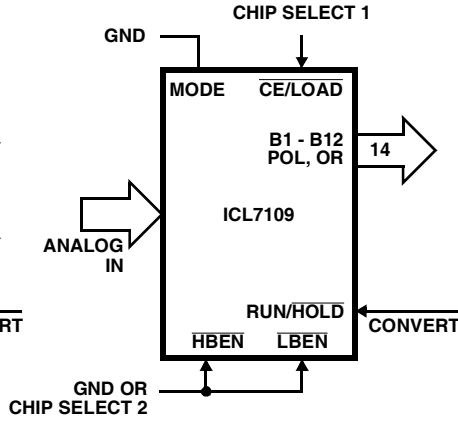

FIGURE 12B.

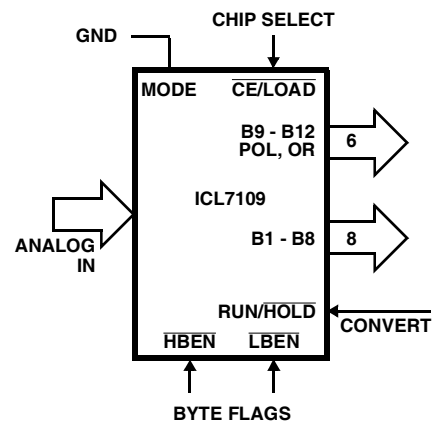

FIGURE 12C.

FIGURE 12. DIRECT MODE CHIP AND BYTE ENABLE COMBINATIONS

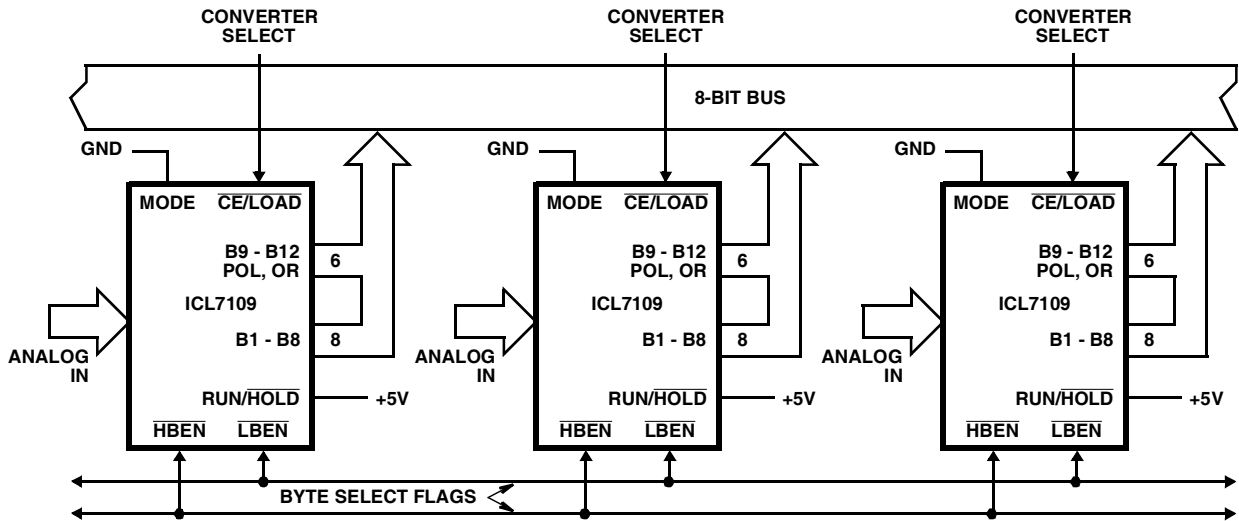

FIGURE 13. THREE-STATE SEVERAL ICL7109'S TO A SMALL BUS

# ICL7109

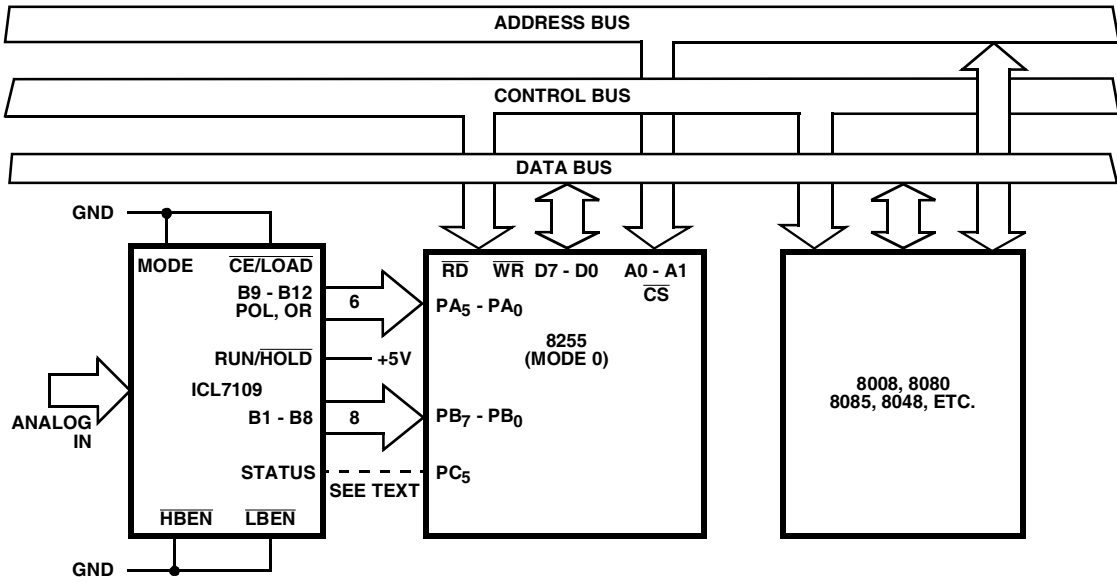

FIGURE 14. FULL-TIME PARALLEL INTERFACE TO 8040/80/85 MICROPROCESSORS

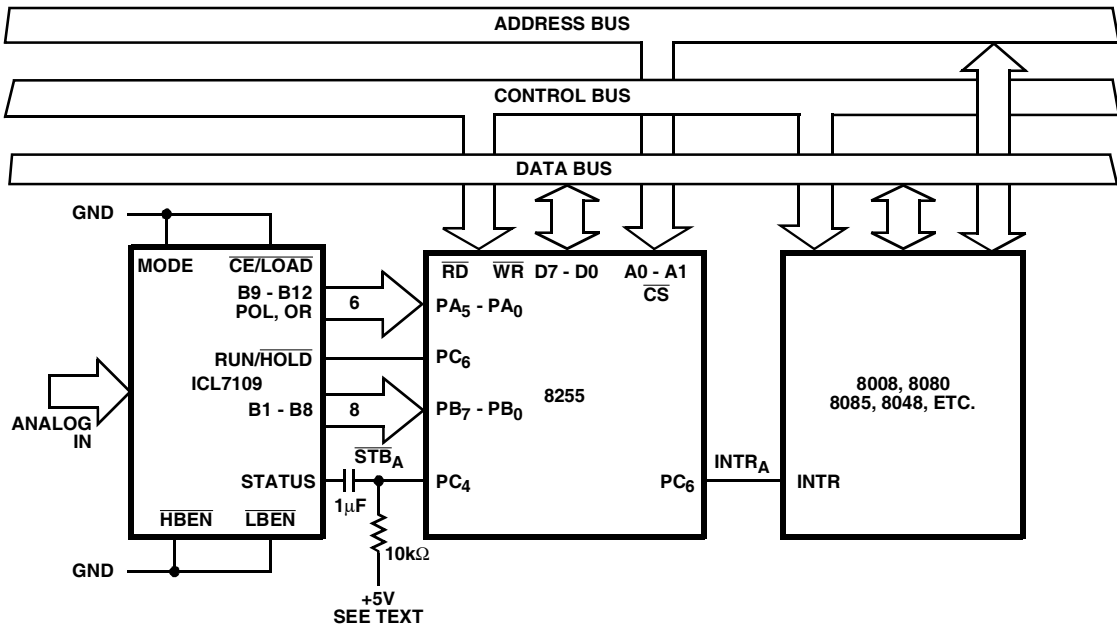
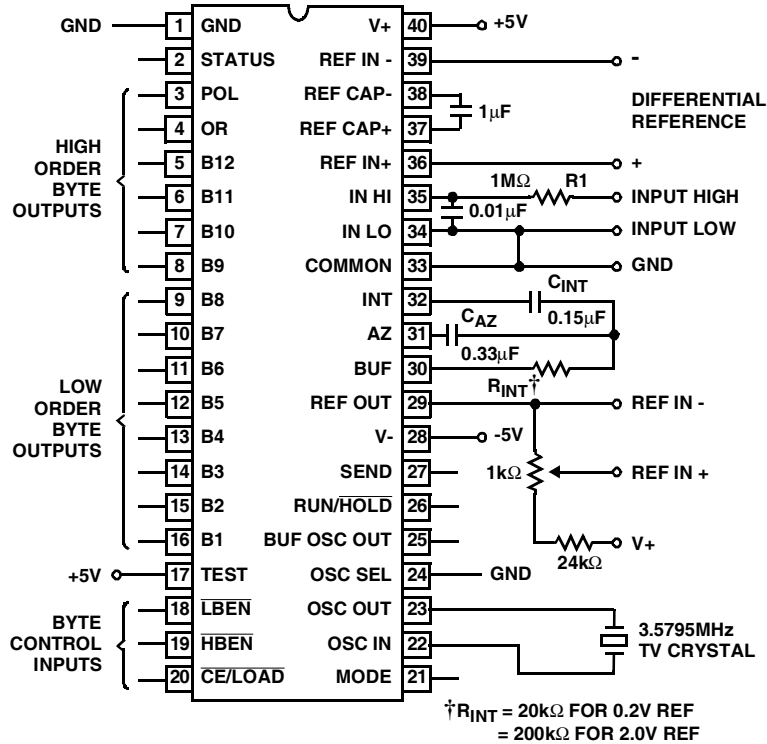

FIGURE 15. FULL-TIME PARALLEL INTERFACE TO 8048/80/85 MICROPROCESSORS WITH INTERRUPT

**Test Circuit**



**Typical Applications**

**Direct Mode Interfacing**

Figure 12 shows some of the combinations of chip enable and byte enable control signals which may be used when interfacing the ICL7109 to parallel data lines. The  $\overline{CE/LOAD}$  input may be tied low, allowing either byte to be controlled by its own enable as in Figure 12A. Figure 12B shows a configuration where the two byte enables are connected together. In this configuration, the  $\overline{CE/LOAD}$  serves as a chip enable, and the  $\overline{HBEN}$  and  $\overline{LBEN}$  may be connected to GND or serve as a second chip enable. The 14 data outputs will all be enabled simultaneously. Figure 12C shows the  $\overline{HBEN}$  and  $\overline{LBEN}$  as flag inputs, and  $\overline{CE/LOAD}$  as a master enable, which could be the READ strobe available from most microprocessors.

Figure 13 shows an approach to interfacing several ICL7109s to a bus, connecting the  $\overline{HBEN}$  and  $\overline{LBEN}$  signals of several converters together, and using the  $\overline{CE/LOAD}$  inputs (perhaps decode from an address) to select the desired converter.

Some practical circuits utilizing the parallel three-state output capabilities of the ICL7109 are shown in Figures 14 through 19. Figure 14 shows a straightforward application to the Intel 8048/80/85 microprocessors via an 8255PPI, where the ICL7109 data outputs are active at all times. The I/O ports of an 8155 may be used in the same way. This interface can be used in a read-anytime mode, although a read performed while the data latches are being updated will lead to scrambled data. This will occur very rarely, in the proportion of

set-up skew times to conversion time. One way to overcome this is to read the STATUS output as well, and if it is high, read the data again after a delay of more than  $1/2$  converter clock period. If STATUS is now low, the second reading is correct, and if it is still high, the first reading is correct. Alternatively, this timing problem is completely avoided by using a read-after-update sequence, as shown in Figure 15. Here the high to low transition of the STATUS output drives an interrupt to the microprocessor causing it to access the data latches. This application also shows the RUN/HOLD input being used to initiate conversions under software control.

A similar interface to Motorola MC6800 or Rockwell R650X systems is shown in Figure 16. The high to low transition of the STATUS output generates an interrupt via the Control Register B CB1 line. Note that CB2 controls the RUN/HOLD pin through Control Register B, allowing software-controlled initiation of conversions in this system as well.

The three-state output capability of the ICL7109 allows direct interfacing to most microprocessor busses. Examples of this are shown in Figures 17 and 18. It is necessary to carefully consider the system in this type of interface, to be sure that requirements for setup and hold times, and minimum pulse widths are met. Note also the drive limitations on long buses. Generally this type of interface is only favored if the memory peripheral address density is low so that simple address decoding can be used. Interrupt handling can also require many additional components, and using an interface device will usually simplify the system in this case.

**Handshake Mode Interfacing**

The handshake mode allows ready interface with a wide variety of external devices. For instance, external latches may be clocked by the rising edge of  $\overline{CE}/LOAD$ , and the byte enables may be used as byte identification flags or as load enables.

Figure 19 shows a handshake interface to Intel microprocessors again using an 8255PPI. The handshake operation with the 8255 is controlled by inverting its Input Buffer Full (IBF) flag to drive the SEND input to the ICL7109, and using the  $\overline{CE}/LOAD$  to drive the 8255 strobe. The internal control register of the PPI should be sent in MODE 1 for the port used. If the ICL7109 is in handshake mode and the 8255 IBF flag is low, the next word will be strobed into the port. The strobe will cause IBF to go high (SEND goes low), which will keep the enable byte outputs active. The PPI will generate an interrupt which when executed will result in the data being read. When the byte is read, the IBF will be reset low, which causes the ICL7109 to sequence into the next byte. This figure shows the MODE input to the ICL7109 connected to a control line on the PPI. If this output is left high, or tied high separately, the data from every conversion (provided the data access takes less time than a conversion) will be sequenced in two bytes into the system.

If this output is made to go from low to high, the output sequence can be obtained on demand, and the interrupt may be used to reset the MODE bit. Note that the RUN/HOLD input to the ICL7109 may also be obtained on command under software control. Note that one port of the

8255 is not used, and can service another peripheral device. The same arrangement can also be used with the 8155.

Figure 20 shows a similar arrangement with the MC6800 or MCS650X microprocessors, except that both MODE and RUN/HOLD are tied high to save port outputs.

The handshake mode is particularly convenient for directly interfacing to industry standard UARTs (such as the Intersil IM6402 or Western Digital TR1602) providing a minimum component count means of serially transmitting converted data. A typical UART connection is shown in Figure 1A. In this circuit, any word received by the UART causes the UART DR (Data Ready) output to go high. This drives the MODE input to the ICL7109 high, triggering the ICL7109 into handshake mode. The high order byte is output to the UART first, and when the UART has transferred the data to the Transmitter Register, TBRE (SEND) goes high again,  $\overline{LBEN}$  will go high, driving the UART DRR (Data Ready Reset) which will signal the end of the transfer of data from the ICL7109 to the UART.

Figure 21 shows an extension of the one converter one UART scheme to several ICL7109s with one UART. In this circuit, the word received by the UART (available at the RBR outputs when DR is high) is used to select which converter will handshake with the UART. With no external components, this scheme will allow up to eight ICL7109s to interface with one UART. Using a few more components to decode the received word will allow up to 256 converters to be accessed on one serial line.

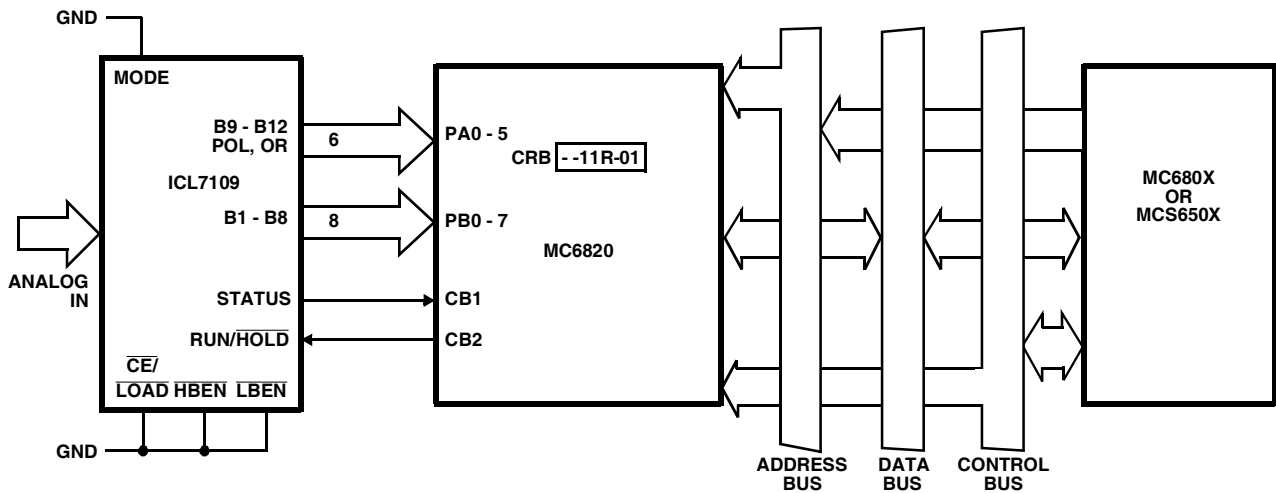

FIGURE 16. FULL-TIME PARALLEL INTERFACE TO MC680X OR MCS650X MICROPROCESSORS

# ICL7109

The applications of the ICL7109 are not limited to those shown here. The purposes of these examples are to provide a starting point for users to develop useful systems and to show some of the variety of interfaces and uses of the combination. In particular the uses of the STATUS, RUN/HOLD, and MODE signals may be mixed.

The following application notes contain very useful information on understanding and applying this part and are available from Intersil Corporation.

## Application Notes

NOTE #	DESCRIPTION	AnswerFAX DOC. #
AN016	"Selecting A/D Converters"	9016
AN017	"The Integrating A/D Converter"	9017
AN018	"Do's and Don'ts of Applying A/D Converters"	9018
AN030	"The ICL7104 - A Binary Output A/D Converter for Microprocessors"	9030
AN032	"Understanding the Auto-Zero and Common Mode Performance of the ICL7136/7/9 Family"	9032

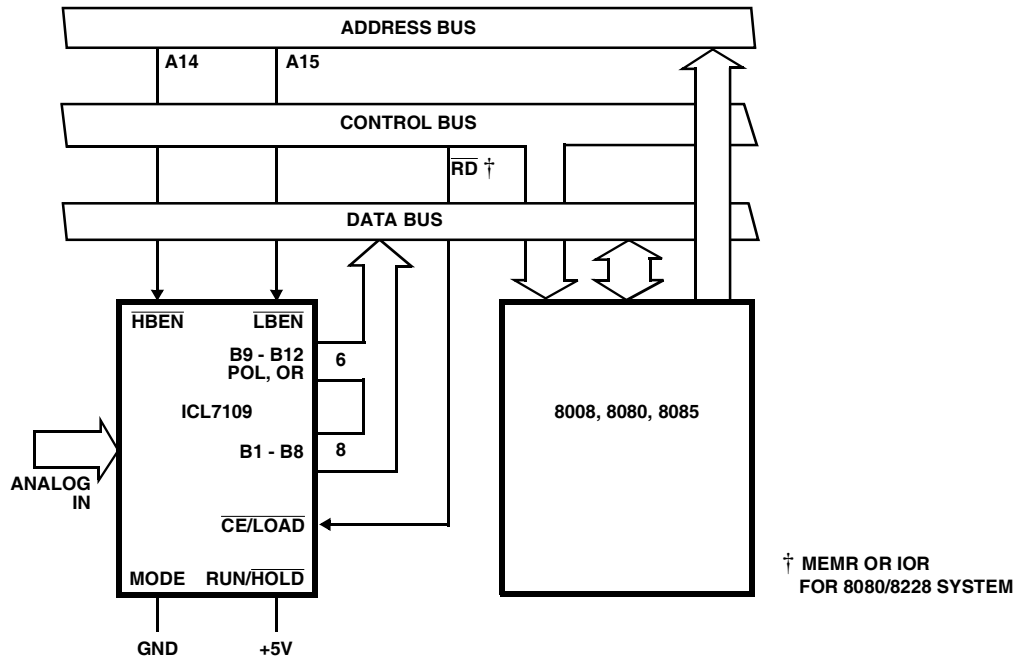

FIGURE 17. DIRECT INTERFACE - ICL7109 TO 8080/8085

# ICL7109

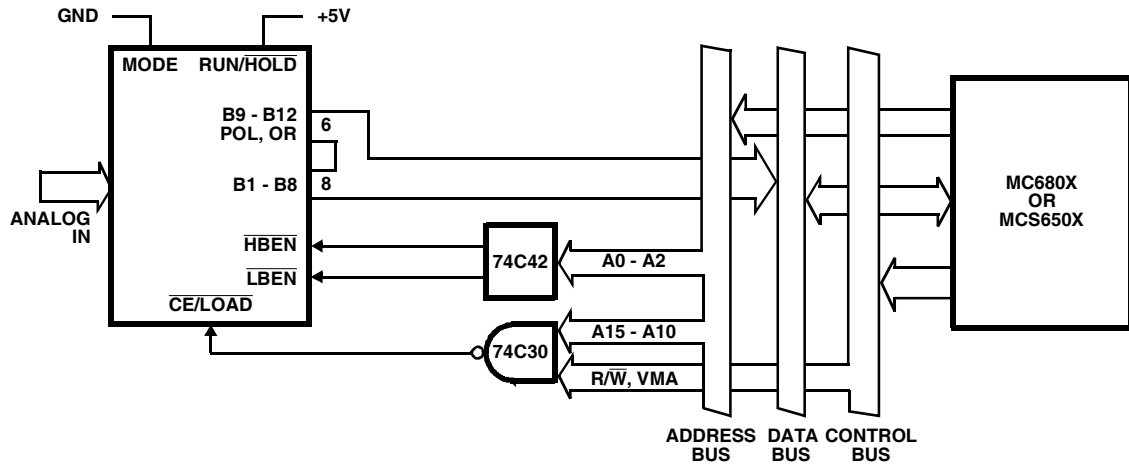

FIGURE 18. DIRECT ICL7109 - MC680X BUS INTERFACE

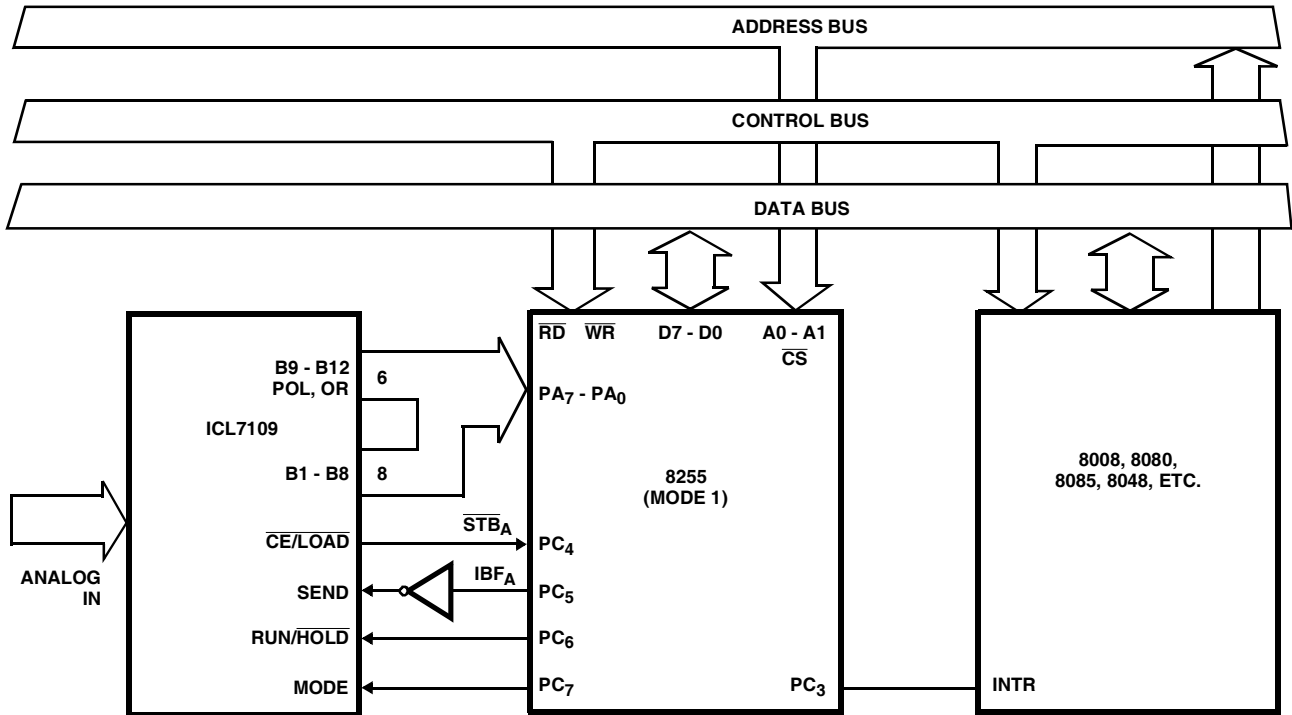

FIGURE 19. HANDSHAKE INTERFACE - ICL7109 TO 8048, 80/85

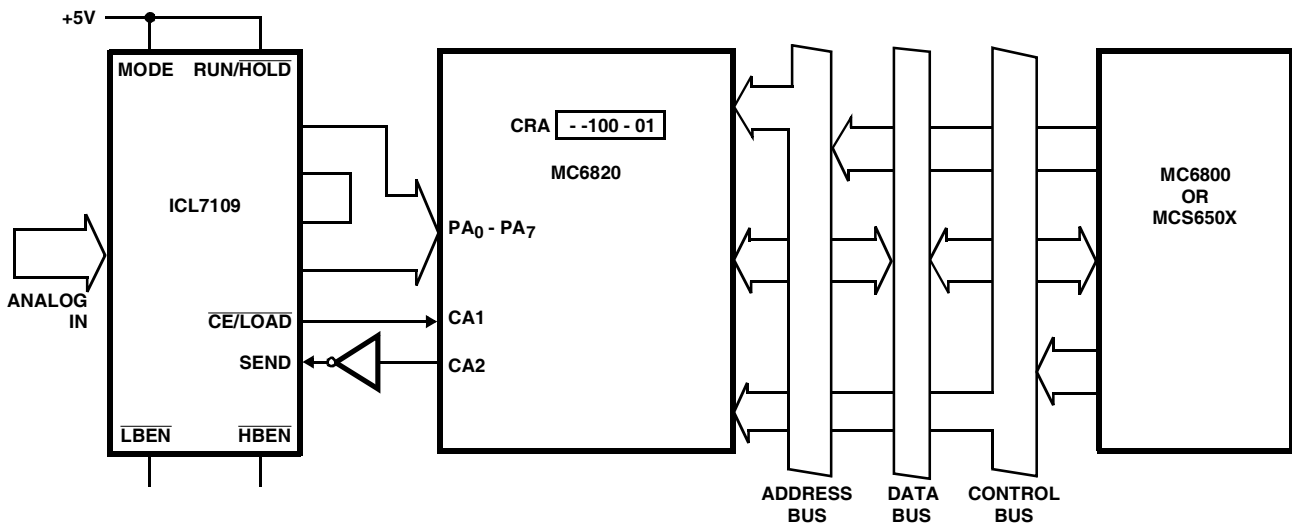

FIGURE 20. HANDSHAKE INTERFACE - ICL7109 TO MC6800, MCS650X

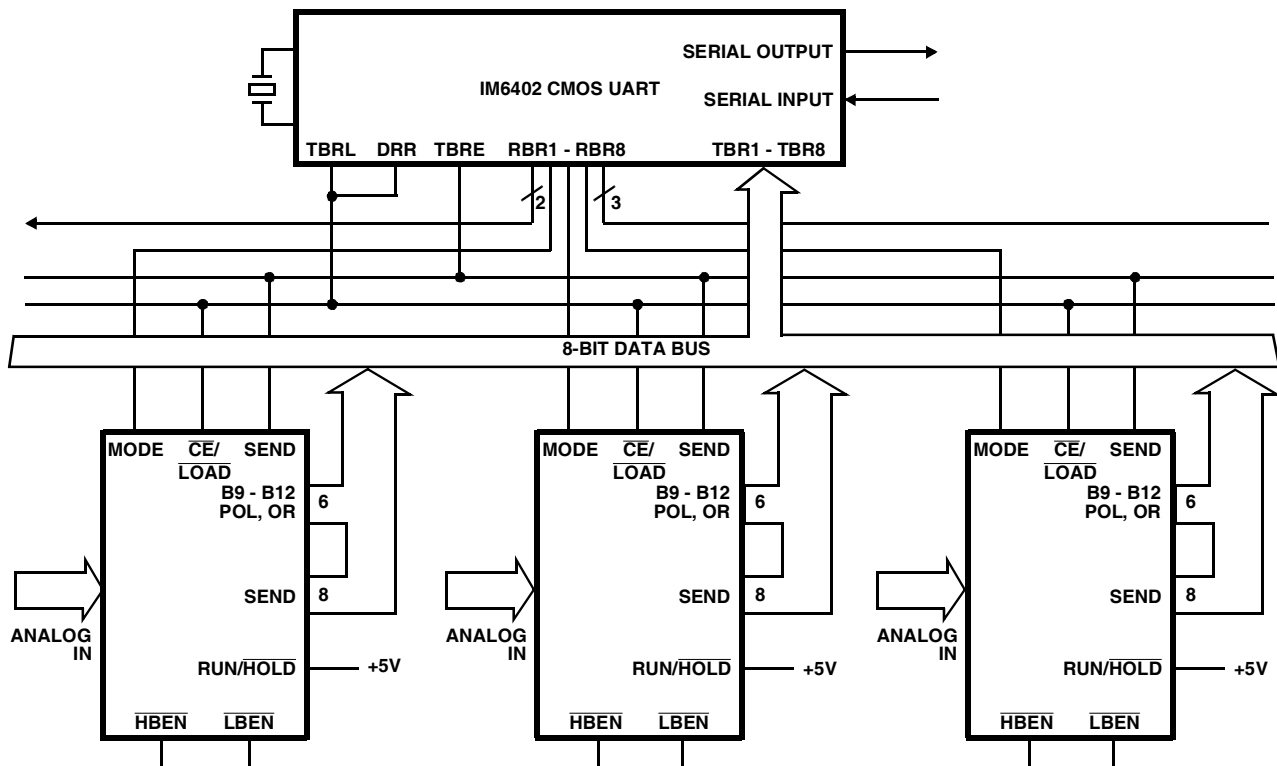

FIGURE 21. MULTIPLEXING CONVERTERS WITH MODE INPUT

## Die Characteristics

### DIE DIMENSIONS:

(122 mils x 135 mils) x 525 $\mu$ m  $\pm$ 25 $\mu$ m Thick

### METALLIZATION:

Type: Al

Thickness: 10k $\text{\AA}$   $\pm$ 1k $\text{\AA}$

### PASSIVATION:

Type: Nitride/Silox Sandwich

Thickness: 8k $\text{\AA}$  Nitride over 7k $\text{\AA}$  Silox

## Metallization Mask Layout

ICL7109

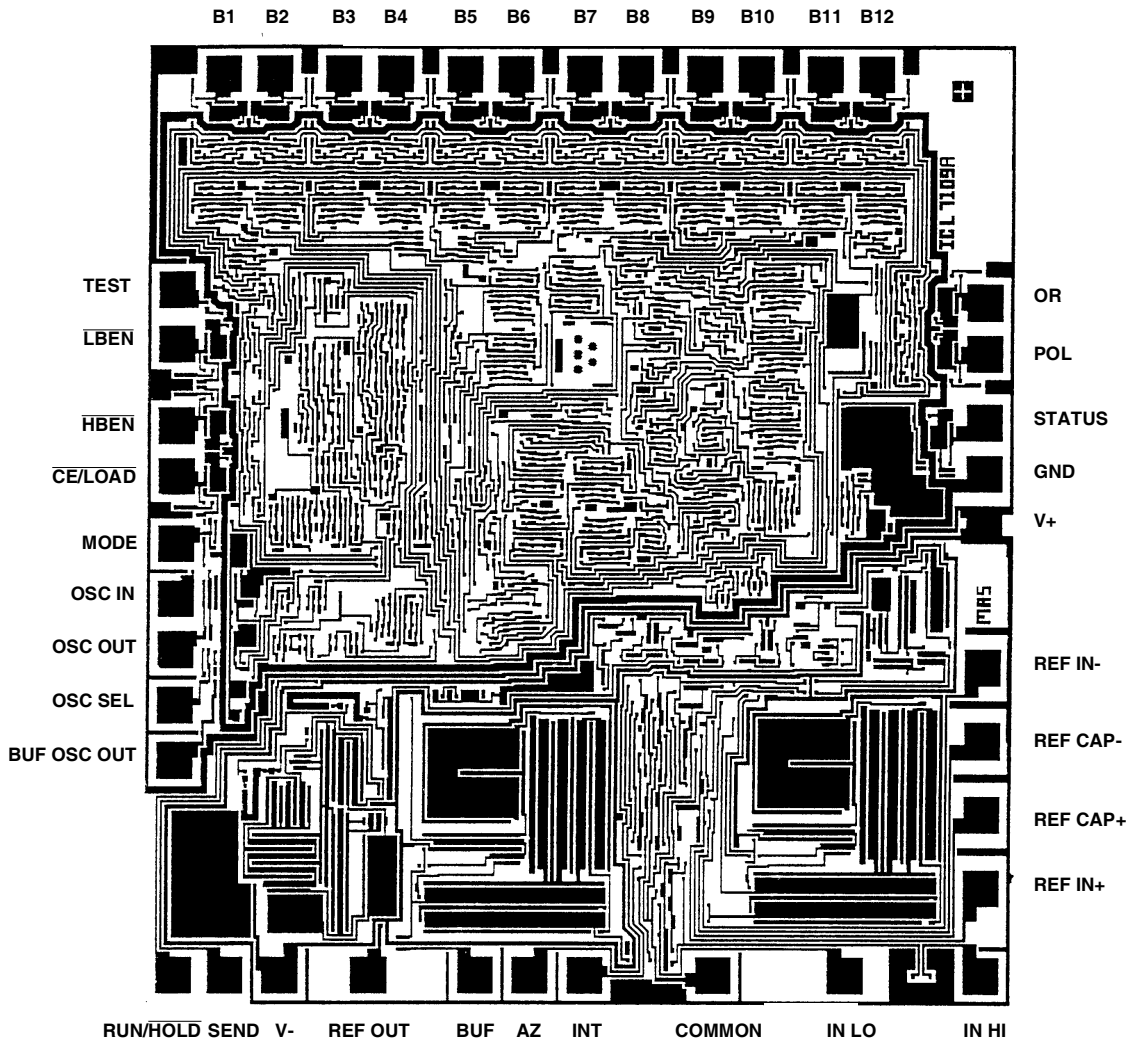

This datasheet has been downloaded from:

[www.DatasheetCatalog.com](http://www.DatasheetCatalog.com)

Datasheets for electronic components.



LittleDiode supplies new, hard to find or obsolete electronic components and semiconductors all over the world.

With over two million different components listed you are sure to find the part you need.

Feel free to visit us today at our online store:

[LittleDiode.com](http://LittleDiode.com)

Looking forward to providing you with the best possible service.