

# DATA SHEET

## **74F657**

Octal transceiver with 8-bit parity generator/checker

Process specification

1990 Jul 30

IC15 Data Handbook

## Octal transceiver with 8-bit parity generator/checker

74F657

## FEATURES

- Combines 74F245 and 74F280A functions in one package
- High impedance base input for reduced loading (70µA in high and low states)
- Ideal in applications where high output drive and light bus loading are required ( $I_{IL}$  is 70µA vs FAST std of 600µA)
- 3–state buffer outputs sink 64mA and source 15mA
- Input diodes for termination effects
- 24–pin plastic slim DIP (300mil) package
- Industrial temperature range available (–40°C to +85°C)

## DESCRIPTION

The 74F657 is an octal transceiver featuring non–inverting buffers with 3–state outputs and an 8–bit parity generator/checker, and is intended for bus–oriented applications. The buffers have a guaranteed current sinking capability of 24mA at the A ports and 64mA at the B ports. The transmit/receive (T/R) input determines the direction of the data flow through the bidirectional transceivers. Transmit (active high) enables data from A ports to B ports; receive (active low) enables data from B ports to A ports. The output enable ( $\overline{OE}$ ) input disables both the A and B ports by placing them in a high impedance condition when the  $\overline{OE}$  input is high.

The parity select ( $\overline{ODD/EVEN}$ ) input gives the user the option of odd or even parity systems.

The parity (PARITY) pin is an output from the generator/checker when transmitting from the port A to B (T/R = high) and an input when receiving from port B to A port (T/R = low).

When transmitting (T/R = high) the parity select ( $\overline{ODD/EVEN}$ ) input is set, then the A port data is polled to determine the number of high bits. The parity (PARITY) output then goes to the logic state determined by the parity select ( $\overline{ODD/EVEN}$ ) setting and by the number of high bits on port A.

For example, if the parity select ( $\overline{ODD/EVEN}$ ) is set low (even parity), and the number of high bits on port A is odd, then the parity (PARITY) output will be high, transmitting even parity. If the number of high bits on port A is even, then the parity (PARITY) output will be low, keeping even parity.

When in receive mode (T/R = low) the B port is polled to determine the number of high bits. If parity select ( $\overline{ODD/EVEN}$ ) is low (even parity) and the number of highs on port B is:

(1) odd and the parity (PARITY) input is high, then  $\overline{ERROR}$  will be high, significantly no error.

(2) even and the parity (PARITY) input is high, then  $\overline{ERROR}$  will be asserted low, indicating an error.

TYPE	TYPICAL PROPAGATION DELAY	TYPICAL SUPPLY CURRENT(TOTAL)
74F657	8.0ns	100mA

## ORDERING INFORMATION

DESCRIPTION	ORDER CODE		PKG DWG #
	COMMERCIAL RANGE $V_{CC} = 5V \pm 10\%$ , $T_{amb} = 0^{\circ}C$ to $+70^{\circ}C$	INDUSTRIAL RANGE $V_{CC} = 5V \pm 10\%$ , $T_{amb} = -40^{\circ}C$ to $+85^{\circ}C$	
24–pin plastic slim DIP (300mil)	N74F657N	I74F657N	SOT222-1
24–pin plastic SOL	N74F657D	I74F657D	SOT137-1
24–pin plastic SSOP	N74F657DB	I74F657DB	SOT340-1

## INPUT AND OUTPUT LOADING AND FAN OUT TABLE

PINS	DESCRIPTION	74F (U.L.) HIGH/LOW	LOAD VALUE HIGH/LOW
A0 – A7	A ports 3–state inputs	3.5/0.117	70µA/70µA
B0 – B7	B ports 3–state inputs	3.5/0.117	70µA/70µA
PARITY	Parity input	3.5/0.117	70µA/70µA
T/R	Transmit/receive input	2.0/0.066	40µA/40µA
$\overline{ODD/EVEN}$	Parity select input	1.0/0.033	20µA/20µA
$\overline{OE}$	Output enable input (active low)	2.0/0.066	40µA/40µA
A0 – A7	A ports 3–state outputs	150/40	3.0mA/24mA
B0 – B7	B ports 3–state outputs	750/106.7	15mA/64mA
PARITY	Parity output	750/106.7	15mA/64mA
ERROR	Error output	750/106.7	15mA/64mA

## Note to input and output loading and fan out table

1. One (1.0) FAST unit load is defined as: 20µA in the high state and 0.6mA in the low state.

# Octal transceiver with 8-bit parity generator/checker

## 74F657

### PIN CONFIGURATION

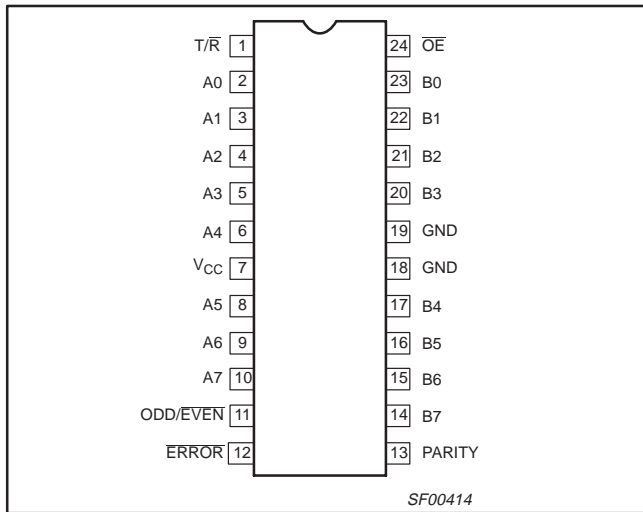

### LOGIC SYMBOL

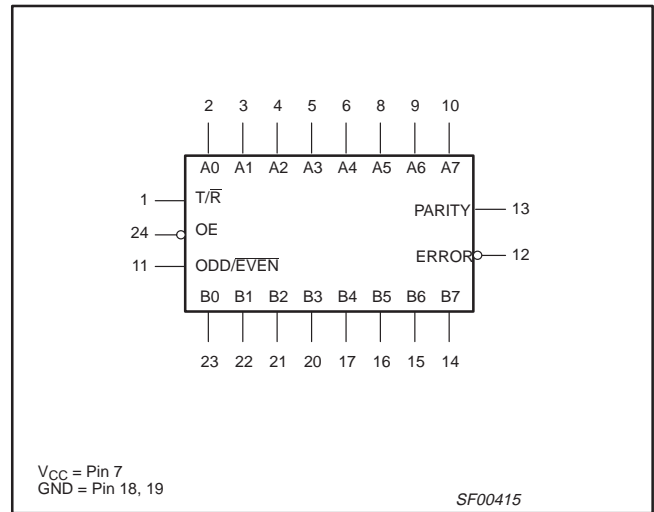

### IEC/IEEE SYMBOL

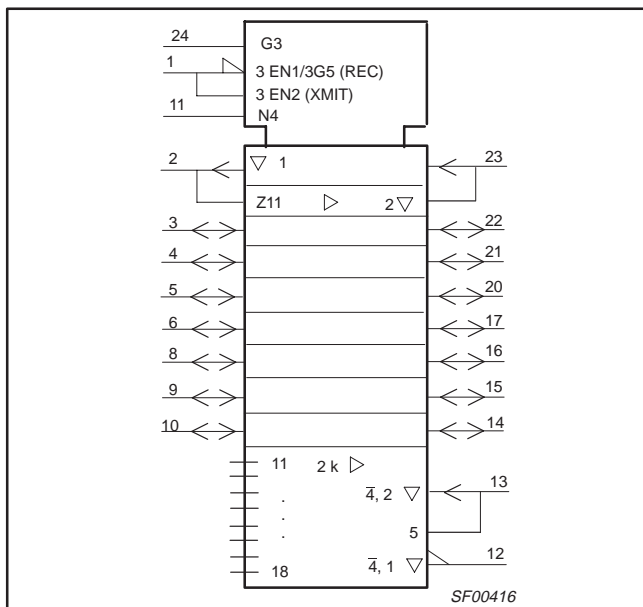

# Octal transceiver with 8-bit parity generator/checker

74F657

## LOGIC DIAGRAM

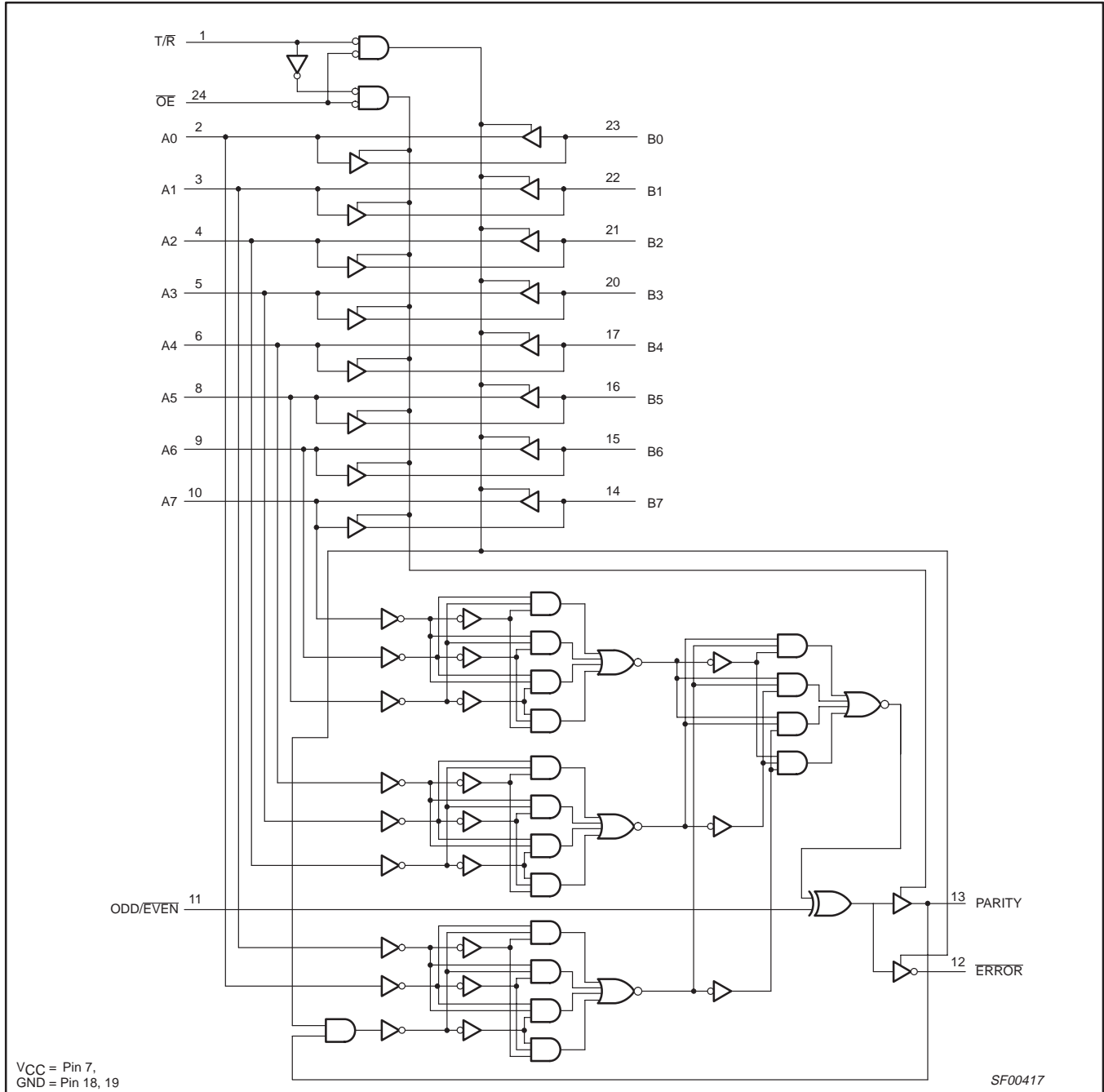

## Octal transceiver with 8-bit parity generator/checker

74F657

## FUNCTION TABLE

NUMBER OF INPUTS THAT ARE HIGH	INPUTS			INPUT/OUTPUT	OUTPUTS	
	OE	T/R	ODD/EVEN	PARITY	ERROR	OUTPUTS MODE
0, 2, 4, 6, 8	L	H	H	H	Z	Transmit
	L	H	L	L	Z	Transmit
	L	L	H	H	H	Receive
	L	L	H	L	L	Receive
	L	L	L	H	L	Receive
	L	L	L	L	H	Receive
1, 3, 5, 7	L	H	H	L	Z	Transmit
	L	H	L	H	Z	Transmit
	L	L	H	H	L	Receive
	L	L	H	L	H	Receive
	L	L	L	H	H	Receive
	L	L	L	L	L	Receive
Don't care	H	X	X	Z	Z	Z

## Notes to function table

1. H = High voltage level
2. L = Low voltage level
3. X = Don't care
4. Z = High impedance "off" state

## ABSOLUTE MAXIMUM RATINGS

(Operation beyond the limit set forth in this table may impair the useful life of the device. Unless otherwise noted these limits are over the operating free air temperature range.)

SYMBOL	PARAMETER	RATING	UNIT
V <sub>CC</sub>	Supply voltage	-0.5 to +7.0	V
V <sub>IN</sub>	Input voltage	-0.5 to +7.0	V
I <sub>IN</sub>	Input current	-30 to +5	mA
V <sub>OUT</sub>	Voltage applied to output in high output state	-0.5 to V <sub>CC</sub>	V
I <sub>OUT</sub>	Current applied to output in low output state	A0 – A7	48
		B0 – B7, PARITY, ERROR	128
T <sub>amb</sub>	Operating free air temperature range	Commercial range	0 to +70
		Industrial range	-40 to +85
T <sub>stg</sub>	Storage temperature range	-65 to +150	°C

## RECOMMENDED OPERATING CONDITIONS

SYMBOL	PARAMETER	LIMITS			UNIT
		MIN	NOM	MAX	
V <sub>CC</sub>	Supply voltage	4.5	5.0	5.5	V
V <sub>IH</sub>	High-level input voltage	2.0			V
V <sub>IL</sub>	Low-level input voltage			0.8	V
I <sub>Ik</sub>	Input clamp current			-18	mA
I <sub>OH</sub>	High-level output current	A0 – A7		-3	mA
		B0 – B7, PARITY, ERROR		-15	mA
I <sub>OL</sub>	Low-level output current	A0 – A7		24	mA
		B0 – B7, PARITY, ERROR		64	mA
T <sub>amb</sub>	Operating free air temperature range	Commercial range	0	+70	°C
		Industrial range	-40	+85	°C

## Octal transceiver with 8-bit parity generator/checker

74F657

**DC ELECTRICAL CHARACTERISTICS**

(Over recommended operating free-air temperature range unless otherwise noted.)

SYMBOL	PARAMETER		TEST CONDITIONS <sup>1</sup>			LIMITS			UNIT
						MIN	TYP <sup>2</sup>	MAX	
V <sub>OH</sub>	High-level output voltage	All outputs	V <sub>CC</sub> = MIN,	I <sub>OH</sub> = -3mA <sup>4,5</sup>	±10%V <sub>CC</sub>	2.4			V
					±5%V <sub>CC</sub>	2.7			V
		B0 – B7, PARITY, ERROR	V <sub>IL</sub> = MAX, V <sub>IH</sub> = MIN	I <sub>OH</sub> = -12mA <sup>5</sup>	±10%V <sub>CC</sub>	2.0			V
					±5%V <sub>CC</sub>	2.0			V
				I <sub>OH</sub> = -15mA <sup>4</sup>	±10%V <sub>CC</sub>	2.0			V
					±5%V <sub>CC</sub>	2.0			V
V <sub>OL</sub>	Low-level output voltage	A0 – A7	V <sub>CC</sub> = MIN,	I <sub>OL</sub> = 24mA <sup>4,5</sup>	±10%V <sub>CC</sub>		0.35	0.50	V
					±5%V <sub>CC</sub>		0.35	0.50	V
		B0 – B7, PARITY, ERROR	V <sub>IL</sub> = MAX, V <sub>IH</sub> = MIN	I <sub>OL</sub> = 48mA <sup>4</sup>	±10%V <sub>CC</sub>		0.38	0.55	V
					±5%V <sub>CC</sub>		0.42	0.55	V
				I <sub>OL</sub> = 48mA <sup>5</sup>	±10%V <sub>CC</sub>		0.42	0.55	V
					±5%V <sub>CC</sub>		0.42	0.55	V
V <sub>IK</sub>	Input clamp voltage		V <sub>CC</sub> = MIN, I <sub>I</sub> = I <sub>IK</sub>			-0.73	-1.2	V	
I <sub>I</sub>	Input current at maximum input voltage	OE, T/R, ODD/EVEN	V <sub>CC</sub> = 0.0V, V <sub>I</sub> = 7.0V				100	μA	
		A0 – A7	V <sub>CC</sub> = 5.5V, V <sub>I</sub> = 5.5V				2	mA	
		B0 – B7					1	mA	
I <sub>IH</sub>	High-level input current	OOD/EVEN	V <sub>CC</sub> = MAX, V <sub>I</sub> = 2.7V				20 <sup>4</sup>	μA	
		OE, T/R					40 <sup>5</sup>	μA	
							40 <sup>4</sup>	μA	
I <sub>IL</sub>	Low-level input current	OOD/EVEN	V <sub>CC</sub> = MAX, V <sub>I</sub> = 0.5V				-20	μA	
		OE, T/R					-40	μA	
I <sub>OZH</sub> + I <sub>IH</sub>	Off-state output current, high-level voltage applied	A0 – A7, B0 – B7,	V <sub>CC</sub> = MAX, V <sub>O</sub> = 2.7V				70	μA	
I <sub>OZL</sub> + I <sub>IL</sub>	Off-state output current, low-level voltage applied	PARITY	V <sub>CC</sub> = MAX, V <sub>O</sub> = 0.5V				-70	μA	
I <sub>OZH</sub>	Off-state output current, High-level voltage applied	ERROR	V <sub>CC</sub> = MAX, V <sub>O</sub> = 2.7V				50	μA	
I <sub>OZL</sub>	Off-state output current, low-level voltage applied		V <sub>CC</sub> = MAX, V <sub>O</sub> = 0.5V				-50	μA	
I <sub>OS</sub>	Short circuit output current <sup>3</sup>	A0 – A7	V <sub>CC</sub> = MAX			-60	-150	mA	
		B0 – B7				-100	-225	mA	
I <sub>CC</sub>	Supply current (total)	I <sub>CCH</sub>	V <sub>CC</sub> = MAX			90	125 <sup>4</sup>	mA	
						90	135 <sup>5</sup>	mA	
		I <sub>CCL</sub>				106	150 <sup>4</sup>	mA	
						106	160 <sup>5</sup>	mA	
	I <sub>CCZ</sub>				98	145	mA		

**Notes to DC electrical characteristics**

- For conditions shown as MIN or MAX, use the appropriate value specified under recommended operating conditions for the applicable type.
- All typical values are at V<sub>CC</sub> = 5V, T<sub>amb</sub> = 25°C.
- Not more than one output should be shorted at a time. For testing I<sub>OS</sub>, the use of high-speed test apparatus and/or sample-and-hold techniques are preferable in order to minimize internal heating and more accurately reflect operational values. Otherwise, prolonged shorting of a high output may raise the chip temperature well above normal and thereby cause invalid readings in other parameter tests. In any sequence of parameter tests, I<sub>OS</sub> tests should be performed last.
- For commercial range.
- For industrial range.

# Octal transceiver with 8-bit parity generator/checker

74F657

## AC ELECTRICAL CHARACTERISTICS

SYMBOL	PARAMETER	TEST CONDITION	LIMITS								UNIT
			T <sub>amb</sub> = +25°C V <sub>CC</sub> = +5.0V C <sub>L</sub> = 50pF, R <sub>L</sub> = 500Ω			T <sub>amb</sub> = 0°C to +70°C V <sub>CC</sub> = +5.0V ± 10% C <sub>L</sub> = 50pF, R <sub>L</sub> = 500Ω		T <sub>amb</sub> = -40°C to +85°C V <sub>CC</sub> = +5.0V ± 10% C <sub>L</sub> = 50pF, R <sub>L</sub> = 500Ω			
			MIN	TYP	MAX	MIN	MAX	MIN	MAX		
t <sub>PLH</sub> t <sub>PHL</sub>	Propagation delay An to Bn or Bn to An	Waveform 2	2.5 3.0	5.5 6.0	7.5 7.5	2.5 3.0	8.0 8.0	2.0 2.5	9.0 9.0	ns	
t <sub>PLH</sub> t <sub>PHL</sub>	Propagation delay An to PARITY	Waveform 1, 2	7.0 7.0	10.0 10.0	14.0 15.0	7.0 7.0	16.0 16.0	5.5 6.5	16.5 19.0	ns	
t <sub>PLH</sub> t <sub>PHL</sub>	Propagation delay ODD/EVEN to PARITY, ERROR	Waveform 1, 2	4.5 4.5	7.5 8.0	11.0 11.5	4.5 4.5	12.0 12.5	3.5 4.0	13.0 15.5	ns	
t <sub>PLH</sub> t <sub>PHL</sub>	Propagation delay Bn to ERROR	Waveform 1, 2	8.0 8.0	14.0 14.0	20.5 20.5	7.5 7.5	22.5 22.5	7.5 7.5	24.5 25.0	ns	
t <sub>PLH</sub> t <sub>PHL</sub>	Propagation delay PARITY to ERROR	Waveform 1, 2	8.0 8.0	11.5 12.0	15.5 15.5	7.5 8.0	16.5 17.0	6.5 6.5	18.5 20.0	ns	
t <sub>PZH</sub> t <sub>PZL</sub>	Output enable time <sup>1</sup> to high or low level	Waveform 3, 4	3.0 4.0	5.5 7.0	8.0 9.5	3.0 4.0	9.0 11.0	2.0 4.0	9.0 13.0	ns	
t <sub>PHZ</sub> t <sub>PLZ</sub>	Output disable time from high or low level	Waveform 3, 4	2.0 2.0	4.5 4.0	7.5 6.0	2.0 2.0	8.0 6.5	1.0 1.0	8.0 7.5	ns	

**Note to AC electrical characteristics**

1. These delay times reflect the 3-state recovery time only and not the signal through the buffers or the parity check circuitry. To assure **VALID** information at the **ERROR** pin, time must be allowed for the signal to propagate through the drivers (B to A), through the parity check circuitry (same as A to PARITY), and to the **ERROR** output. **VALID** data at the **ERROR** pin ≥ (B to A) + (A to PARITY).

## AC WAVEFORMS

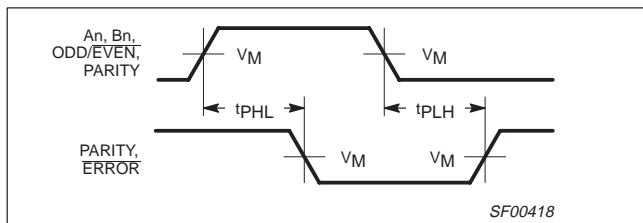

**Waveform 1. Propagation delay for inverting outputs**

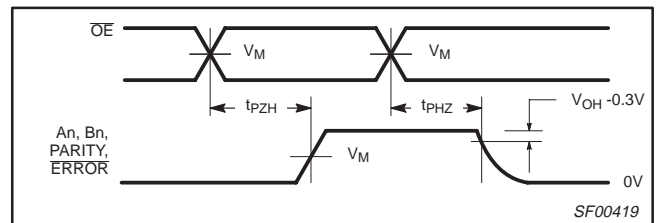

**Waveform 3. 3-state output enable time to high level and output disable time from high level**

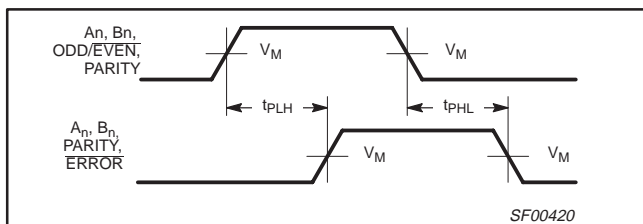

**Waveform 2. Propagation delay for non-inverting outputs**

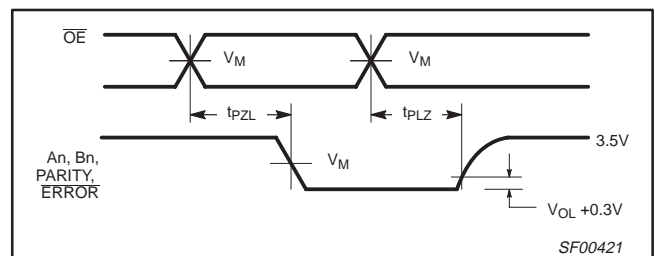

**Waveform 4. 3-state output enable time to low level and output disable time from low level**

**Note to AC waveforms**

1. For all waveforms, V<sub>M</sub> = 1.5V.

# Octal transceiver with 8-bit parity generator/checker

# 74F657

## TEST CIRCUIT AND WAVEFORMS

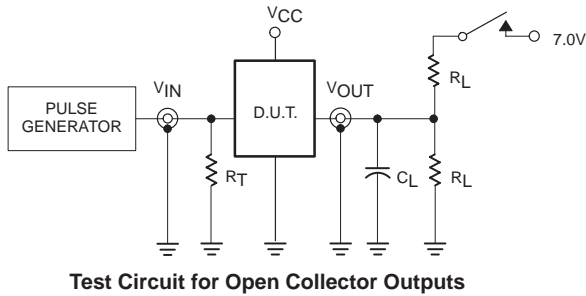

### SWITCH POSITION

TEST	SWITCH
$t_{PLZ}$	closed
$t_{PZL}$	closed
All other	open

### DEFINITIONS:

- $R_L$  = Load resistor; see AC electrical characteristics for value.
- $C_L$  = Load capacitance includes jig and probe capacitance; see AC electrical characteristics for value.
- $R_T$  = Termination resistance should be equal to  $Z_{OUT}$  of pulse generators.

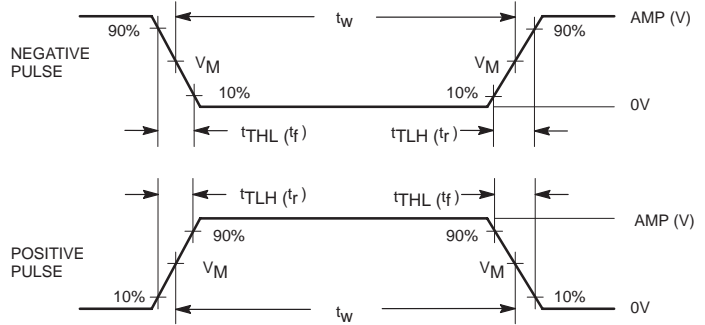

family	INPUT PULSE REQUIREMENTS					
	amplitude	$V_M$	rep. rate	$t_w$	$t_{TLH}$	$t_{THL}$
74F	3.0V	1.5V	1MHz	500ns	2.5ns	2.5ns

SF00128

# Octal transceiver with 8-bit parity generator/checker

## 74F657

DIP24: plastic dual in-line package; 24 leads (300 mil)

SOT222-1

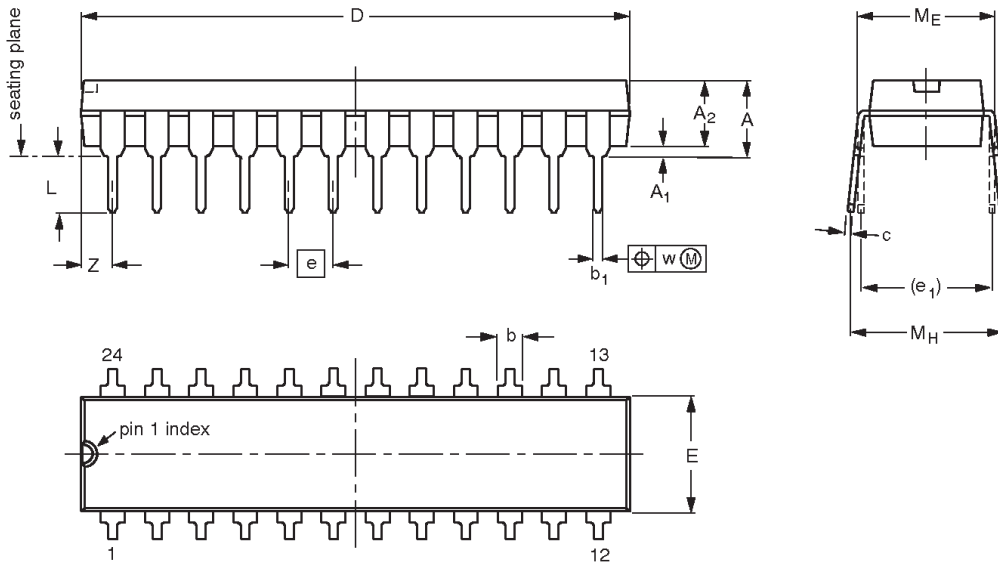

**DIMENSIONS (millimetre dimensions are derived from the original inch dimensions)**

UNIT	A max.	A <sub>1</sub> min.	A <sub>2</sub> max.	b	b <sub>1</sub>	c	D <sup>(1)</sup>	E <sup>(1)</sup>	e	e <sub>1</sub>	L	M <sub>E</sub>	M <sub>H</sub>	w	Z <sup>(1)</sup> max.
mm	4.70	0.38	3.94	1.63 1.14	0.56 0.43	0.36 0.25	31.9 31.5	6.73 6.48	2.54	7.62	3.51 3.05	8.13 7.62	10.03 7.62	0.25	2.05
inches	0.185	0.015	0.155	0.064 0.045	0.022 0.017	0.014 0.010	1.256 1.240	0.265 0.255	0.100	0.300	0.138 0.120	0.32 0.30	0.395 0.300	0.01	0.081

**Note**

1. Plastic or metal protrusions of 0.01 inches maximum per side are not included.

OUTLINE VERSION	REFERENCES				EUROPEAN PROJECTION	ISSUE DATE
	IEC	JEDEC	EIAJ			
SOT222-1		MS-001AF				95-03-11

# Octal transceiver with 8-bit parity generator/checker

## 74F657

**SO24:** plastic small outline package; 24 leads; body width 7.5 mm

**SOT137-1**

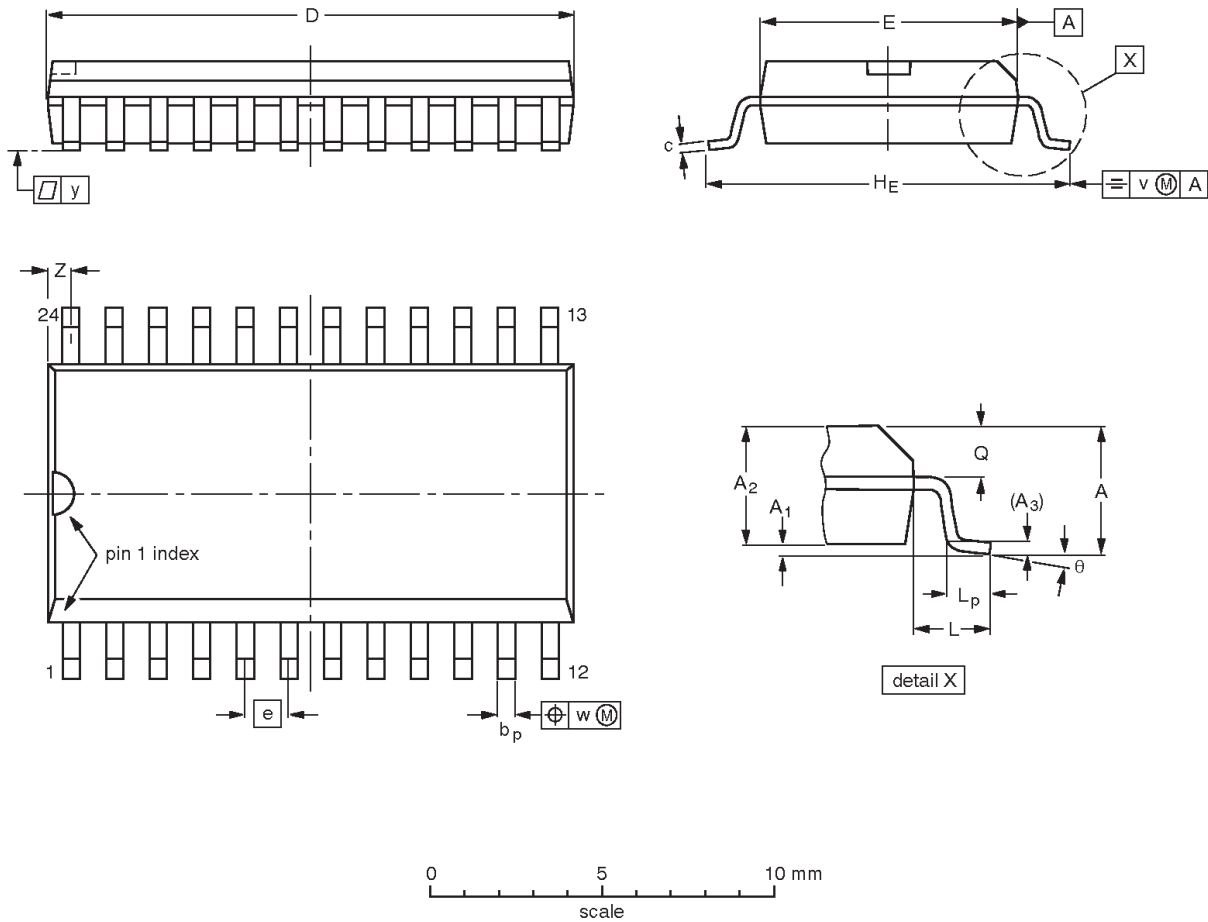

**DIMENSIONS (inch dimensions are derived from the original mm dimensions)**

UNIT	A max.	A <sub>1</sub>	A <sub>2</sub>	A <sub>3</sub>	b <sub>p</sub>	c	D <sup>(1)</sup>	E <sup>(1)</sup>	e	H <sub>E</sub>	L	L <sub>p</sub>	Q	v	w	y	Z <sup>(1)</sup>	θ
mm	2.65	0.30 0.10	2.45 2.25	0.25	0.49 0.36	0.32 0.23	15.6 15.2	7.6 7.4	1.27	10.65 10.00	1.4	1.1 0.4	1.1 1.0	0.25	0.25	0.1	0.9 0.4	8° 0°
inches	0.10	0.012 0.004	0.096 0.089	0.01	0.019 0.014	0.013 0.009	0.61 0.60	0.30 0.29	0.050	0.419 0.394	0.055	0.043 0.016	0.043 0.039	0.01	0.01	0.004	0.035 0.016	

**Note**

1. Plastic or metal protrusions of 0.15 mm maximum per side are not included.

OUTLINE VERSION	REFERENCES				EUROPEAN PROJECTION	ISSUE DATE
	IEC	JEDEC	EIAJ			
SOT137-1	075E05	MS-013AD				95-01-24 97-05-22

# Octal transceiver with 8-bit parity generator/checker

## 74F657

**SSOP24:** plastic shrink small outline package; 24 leads; body width 5.3 mm

**SOT340-1**

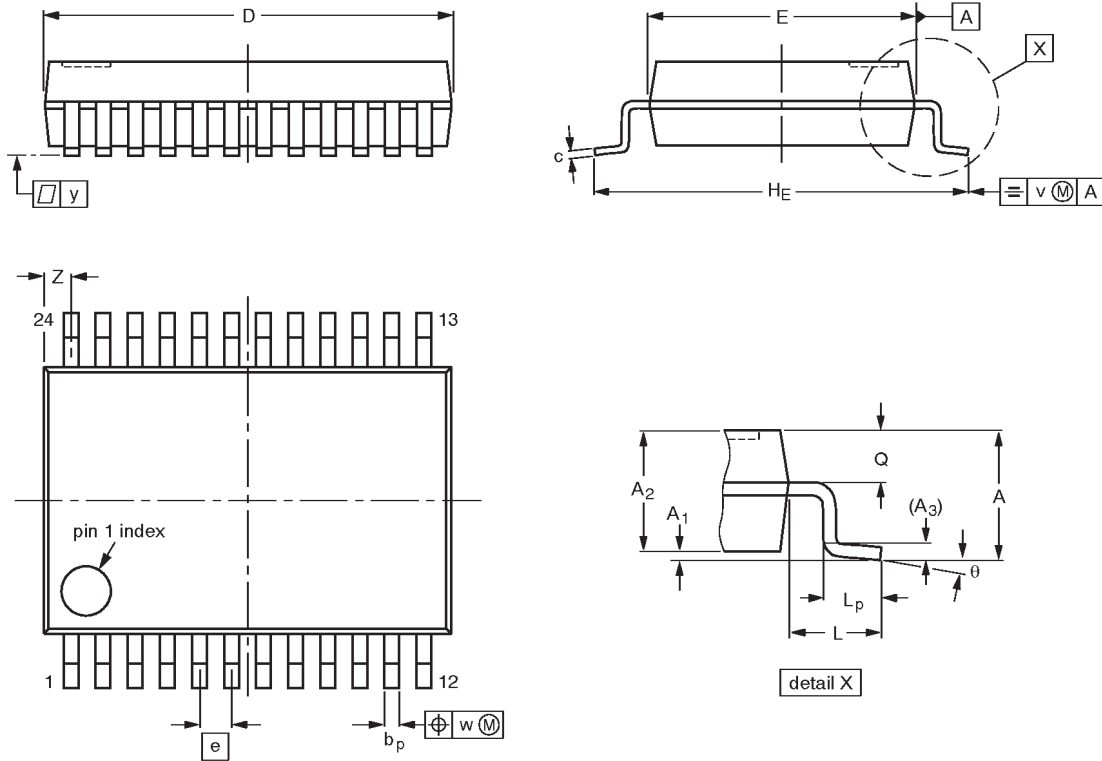

**DIMENSIONS (mm are the original dimensions)**

UNIT	A max.	A <sub>1</sub>	A <sub>2</sub>	A <sub>3</sub>	b <sub>p</sub>	c	D <sup>(1)</sup>	E <sup>(1)</sup>	e	H <sub>E</sub>	L	L <sub>p</sub>	Q	v	w	y	Z <sup>(1)</sup>	θ
mm	2.0	0.21 0.05	1.80 1.65	0.25	0.38 0.25	0.20 0.09	8.4 8.0	5.4 5.2	0.65	7.9 7.6	1.25	1.03 0.63	0.9 0.7	0.2	0.13	0.1	0.8 0.4	8° 0°

**Note**

1. Plastic or metal protrusions of 0.20 mm maximum per side are not included.

OUTLINE VERSION	REFERENCES				EUROPEAN PROJECTION	ISSUE DATE
	IEC	JEDEC	EIAJ			
SOT340-1		MO-150AG				93-09-08 95-02-04

## Octal transceiver with 8-bit parity generator/checker

74F657

## Data sheet status

Data sheet status	Product status	Definition [1]
Objective specification	Development	This data sheet contains the design target or goal specifications for product development. Specification may change in any manner without notice.
Preliminary specification	Qualification	This data sheet contains preliminary data, and supplementary data will be published at a later date. Philips Semiconductors reserves the right to make changes at any time without notice in order to improve design and supply the best possible product.
Product specification	Production	This data sheet contains final specifications. Philips Semiconductors reserves the right to make changes at any time without notice in order to improve design and supply the best possible product.

[1] Please consult the most recently issued datasheet before initiating or completing a design.

## Definitions

**Short-form specification** — The data in a short-form specification is extracted from a full data sheet with the same type number and title. For detailed information see the relevant data sheet or data handbook.

**Limiting values definition** — Limiting values given are in accordance with the Absolute Maximum Rating System (IEC 134). Stress above one or more of the limiting values may cause permanent damage to the device. These are stress ratings only and operation of the device at these or at any other conditions above those given in the Characteristics sections of the specification is not implied. Exposure to limiting values for extended periods may affect device reliability.

**Application information** — Applications that are described herein for any of these products are for illustrative purposes only. Philips Semiconductors make no representation or warranty that such applications will be suitable for the specified use without further testing or modification.

## Disclaimers

**Life support** — These products are not designed for use in life support appliances, devices or systems where malfunction of these products can reasonably be expected to result in personal injury. Philips Semiconductors customers using or selling these products for use in such applications do so at their own risk and agree to fully indemnify Philips Semiconductors for any damages resulting from such application.

**Right to make changes** — Philips Semiconductors reserves the right to make changes, without notice, in the products, including circuits, standard cells, and/or software, described or contained herein in order to improve design and/or performance. Philips Semiconductors assumes no responsibility or liability for the use of any of these products, conveys no license or title under any patent, copyright, or mask work right to these products, and makes no representations or warranties that these products are free from patent, copyright, or mask work right infringement, unless otherwise specified.

Philips Semiconductors  
811 East Arques Avenue  
P.O. Box 3409  
Sunnyvale, California 94088-3409  
Telephone 800-234-7381

© Copyright Philips Electronics North America Corporation 1998  
All rights reserved. Printed in U.S.A.

print code

Date of release: 10-98

Document order number:

9397-750-05171

*Let's make things better.*



LittleDiode supplies new, hard to find or obsolete electronic components and semiconductors all over the world.

With over two million different components listed you are sure to find the part you need.

Feel free to visit us today at our online store:

[LittleDiode.com](http://LittleDiode.com)

Looking forward to providing you with the best possible service.