

DOUBLE SCART INTERFACE

- TWO PERIPLUGS I/O SOURCES MANAGEMENT
- TWO 150Ω INTEGRATED BUFFERS FOR PLUG DRIVE
- ONE OUTPUT WITH MUTING CAPABILITY
- 3 DIGITAL BUFFER OUTPUTS FOR EXTERNAL SWITCHES CONTROL
- LARGE SUPPLY VOLTAGE RANGE
- BANDWIDTH : 19MHz typ.
- CROSSTALK : 50dB min.
- I²C BUS CONTROL

DESCRIPTION

The STV6400 is a bipolar circuit for TV and VCR applications.

It is intended to process all switches relating to a 2 periplugs I/O application

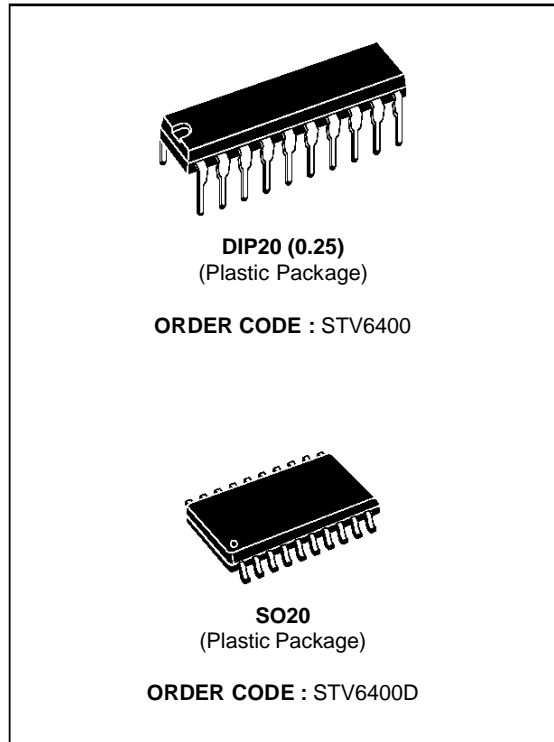

PIN CONNECTIONS

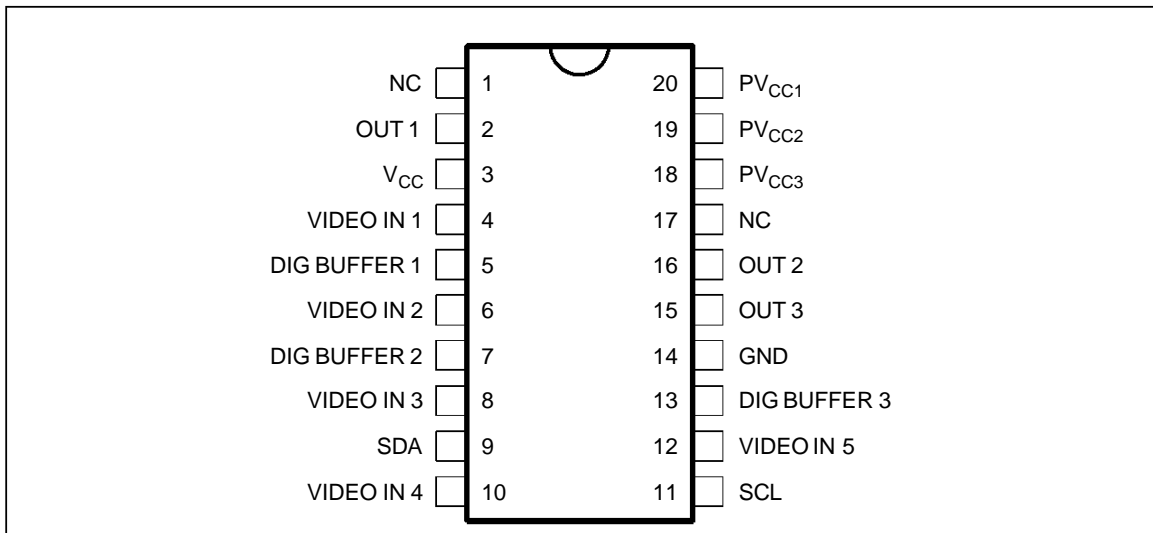

6400-01.EPS

STV6400

BLOCK DIAGRAM

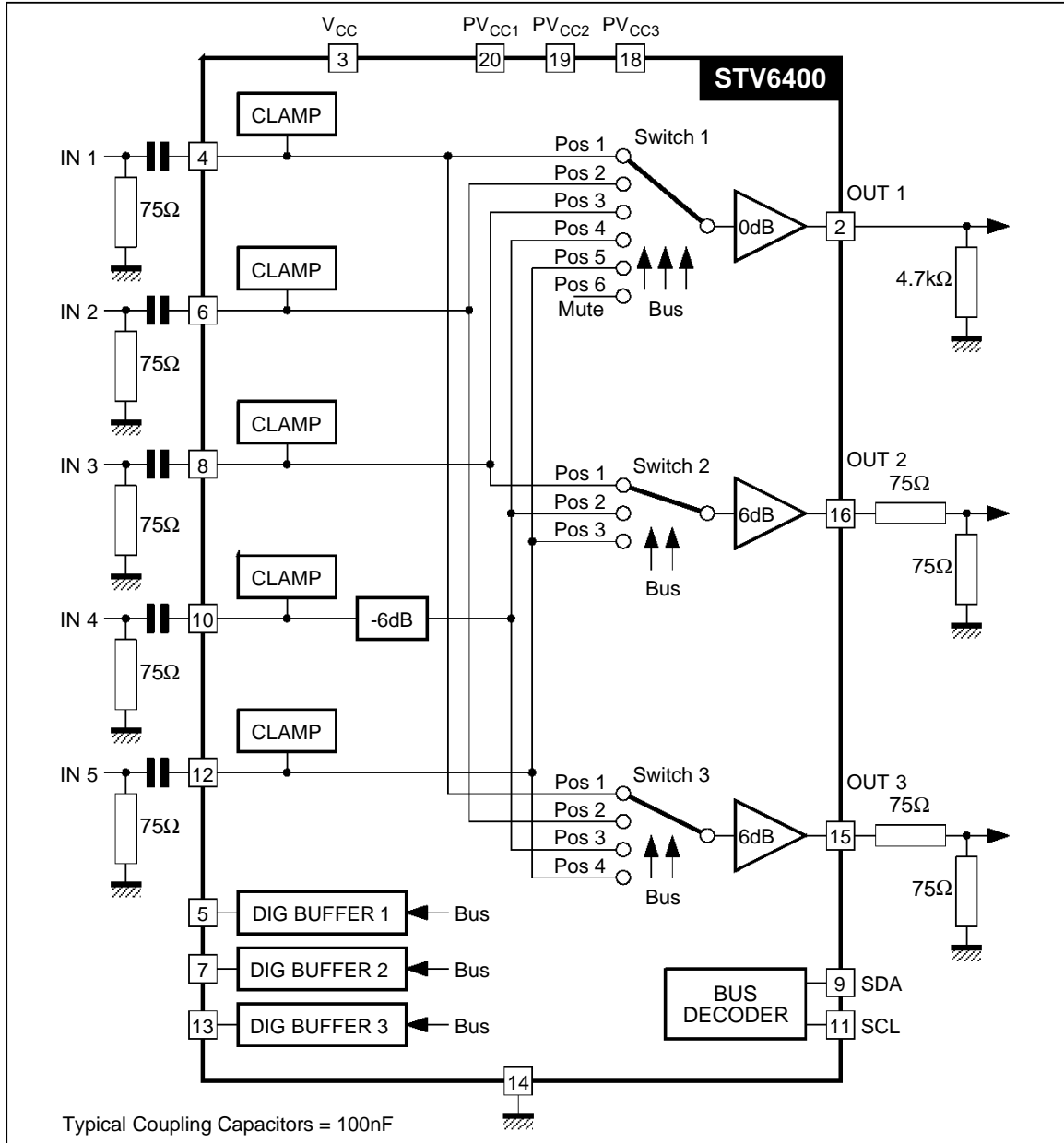

6400-02.EPS

ABSOLUTE MAXIMUM RATINGS

Symbol	Parameter	Value	Unit
V _{CC}	Supply Voltage	12.0	V
T _{oper}	Operating Temperature	-10, + 70	°C
T _{stg}	Storage Temperature	-55, + 150	°C

6400-01.TBL

THERMAL DATA

Symbol	Parameter	Value	Unit
R _{th (j-a)}	Junction-ambient Thermal Resistance	DIP20	70
		SO20	100

6400-02.TBL

DC AND AC ELECTRICAL CHARACTERISTICS

V_{CC} = 5V, T_{amb} = 25°C (Unless otherwise specified)R_{LOAD OUT1} = 4.7kΩ, R_{LOAD OUT2 OUT3} = 150Ω, V_{IN} = 1V_{PP}

Symbol	Parameter	Test conditions	Min.	Typ.	Max.	Unit
V _{CC}	Operating Supply Voltage		4,75	5	11.0	V
I _{CC}	Supply Current	Without loads		27	40	mA
S _{vr}	Supply Voltage Rejection	1kHz		-36		dB

VIDEO INPUTS

V _{DCIN}	DC Input Voltage (black level)			1,4		V
I _{LCAK}	Leakage Current Input			1	3	μA
CAPIN	Input Capacitance			5		pF
V _{IN0}	Input Signal Amplitude	Video 4			2.5	V _{PP}
V _{IN6}	Input Signal Amplitude	Video 1 2 3 5			1.5	V _{PP}

VIDEO OUTPUTS

DYN	Dynamic Output Signal (out 1)	V _{CC} = 5V	2,5			V _{PP}
DYN	Dynamic Output Signal (out 1)	V _{CC} = 4.75V	2,3			V _{PP}
DYN	Dynamic Output Signal (out 2,3)	V _{CC} = 5V V _{CC} = 4.75V	3 2.8			V _{PP} V _{PP}
BW0	0dB Gain Bandwidth at -3dB	V _{IN} = 1V _{PP}	10	23		MHz
BW6	6dB Gain Bandwidth at -3dB	V _{IN} = 1V _{PP}	10	19		MHz
CT*	Crosstalk between Input 1, 2, 3, 5 and Output 2,3	V _{IN} = 1V _{PP} , f = 5MHz		-62	-53	dB
CT*	Crosstalk between Input 4, and Output 2,3	V _{IN4} = 2V _{PP} , f = 5MHz		-60	-52	dB
CT*	Crosstalk between Input 1, 2, 3, 5 and Output 1	V _{IN} = 1V _{PP} , f = 5MHz		-60	-55	dB
CT*	Crosstalk between Input 4 and Output 1	V _{IN4} = 2V _{PP} , f = 5MHz		-53	-50	dB
Z _{OUT}	Output Impedance			4	10	Ω
G ₀	0dB Gain		-0.5	0	+0.5	dB
G ₆	6dB Gain		5.5	6	6.5	dB
DCOUT	DC Output Voltage			0.7		V
DPH10	Differential Phase 0dB Output	V _{IN} = 1V _{PP}		0.25		
DPH6	Differential Phase 6dB Output	V _{IN} = 1V _{PP}		0.5		
DGAIN0	Differential Gain 0dB Output	V _{IN} = 1V _{PP}		1.5		%
DGAIN6	Differential Gain 6dB Output	V _{IN} = 1V _{PP}		1.8		%
MUTE	Muting Suppression at Output 1	V _{IN} = 1V _{PP} , f = 5MHz		-50	-45	dB

DIGITAL BUFFERS

V _{OL}	Low Level Output Voltage	I = 3 mA			0,4	V
Z _{OUT}	Output Resistance at High Level			30		kΩ
DCMAX	Max DC Voltage				V _{CC}	V

* DIP20 package.

6400-03.TBL

I²C BUS CHARACTERISTICS

Symbol	Parameter	Test Conditions	Min.	Max.	Unit
SCL					
V _{IL}	Low Level Input Voltage		- 0.3	+ 1.5	V
V _{IH}	High Level Input Voltage		3.0	V _{CC} + 0.5	V
I _{LI}	Input Leakage Current	V _I = 0 to V _{CC}	- 10	+ 10	μA
f _{SCL}	Clock Frequency		0	100	kHz
t _R	Input Rise Time	1.5V to 3V		1000	ns
t _F	Input Fall Time	1.5V to 3V		300	ns
C _I	Input Capacitance			10	pF
SDA					
V _{IL}	Low Level Input Voltage		- 0.3	+ 1.5	V
V _{IH}	High Level Input Voltage		3.0	V _{CC} + 0.5	V
I _{LI}	Input Leakage Current	V _I = 0 to V _{CC}	- 10	+ 10	μA
C _I	Input Capacitance			10	pF
t _R	Input Rise Time	1.5V to 3V		1000	ns
t _F	Input Fall Time	1.5V to 3V		300	ns
V _{OL}	Low Level Output Voltage	I _{OL} = 3mA		0.4	V
t _F	Output Fall Time	3V to 1.5V		250	ns
C _L	Load Capacitance			400	pF
TIMING					
t _{LOW}	Clock Low Period		4.7		μs
t _{HIGH}	Clock High Period		4.0		μs
t _{SU,DAT}	Data Set-up Time		250		ns
t _{HD,DAT}	Data Hold Time		0	340	ns
t _{SU,STO}	Set-up Time from Clock High to Stop		4.0		μs
t _{BUF}	Start Set-up Time following a Stop		4.7		μs
t _{HD,STA}	Start Hold Time		4.0		μs
t _{SU,STA}	Start Set-up Time following Clock Low-to-High Transition		4.7		μs

6400-04.TBL

Figure 1 : I²C Bus Timing

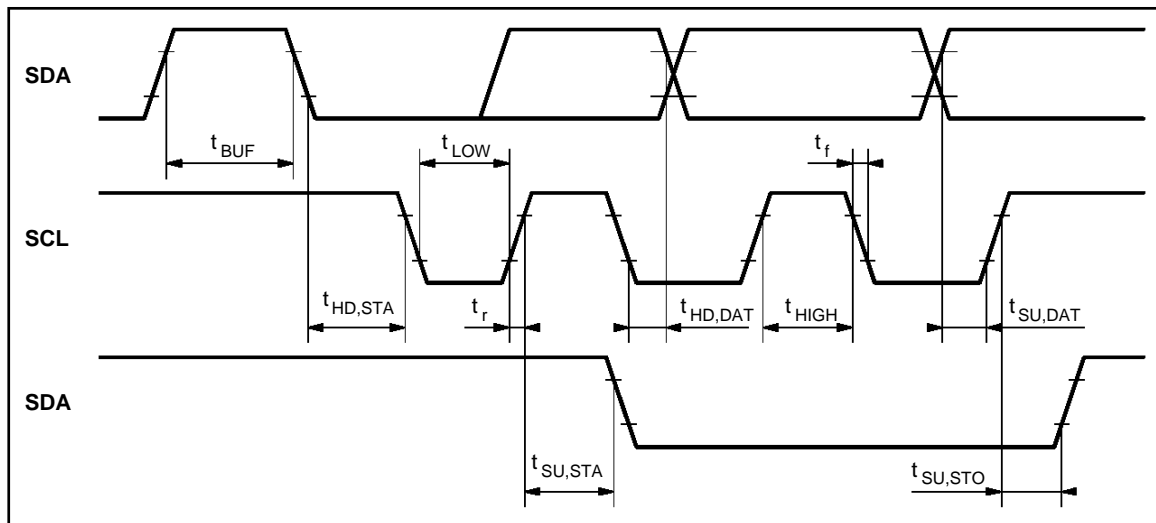

6400-03.EPS

SOFTWARE SPECIFICATION

I²C Address Byte

92 HEXA

DATA BYTE

B7	B6	B5	B4	B3	B2	B1	B0	
X	X	0	0		0 0 0 0 1 1 1 1	0 0 1 1 0 1 1 1	0 1 0 1 0 1 0 1	SWITCH 1 POSITION 1 VIDEO IN 1 POSITION 2 VIDEO IN 2 POSITION 3 VIDEO IN 3 POSITION 4 VIDEO IN 4 POSITION 5 VIDEO IN 5 POSITION 6 MUTE NOT ALLOWED NOT ALLOWED
X	X	0	1		X X X X	0 0 1 1	0 1 0 1	SWITCH 2 POSITION 1 VIDEO IN 3 POSITION 2 VIDEO IN 4 POSITION 3 VIDEO IN 5 NOT ALLOWED
X	X	1	0		X X X X	0 0 1 1	0 1 0 1	SWITCH 2 POSITION 1 VIDEO IN 1 POSITION 2 VIDEO IN 2 POSITION 3 VIDEO IN 4 POSITION 4 VIDEO IN 5
X	X	1	1		X X 1/0	X 1/0 X	1/0 X X	DIGITAL BUFFER DIG BUFFER 1 DIG BUFFER 2 DIG BUFFER 3

Remark : The letter "X" means don't care.

Example : XX00X100 means. The switch 1 is connected to Video input 5

Example : XX11X011 means. Digital buffer 1 is at high level
Digital buffer 2 is at high level
Digital buffer 3 is at low level

The starting condition upon power-on is undetermined.

In this case 4 words of 16 bits are necessary to fix the device configuration.

In other case only one word of 16 bits is necessary to modify one configuration of the device.

INPUT/OUTPUT PIN CONFIGURATION

Pins 4-6-8-10-12 Video Input

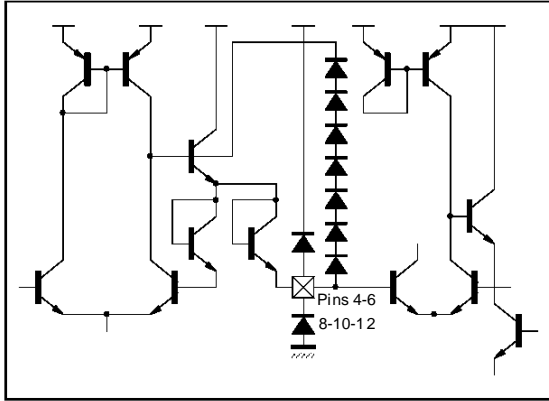

6400-04.EPS

Pins 9 - 11 Bus Inputs

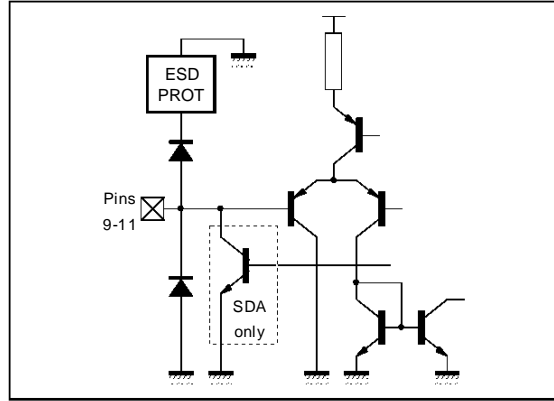

6400-06.EPS

Pins 5-7-13 Digital Buffer Output

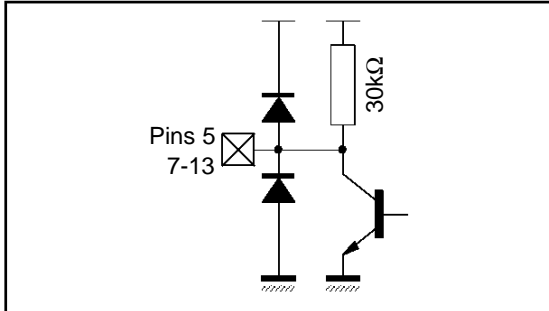

6400-05.EPS

Pins 3-14 Supply Voltage

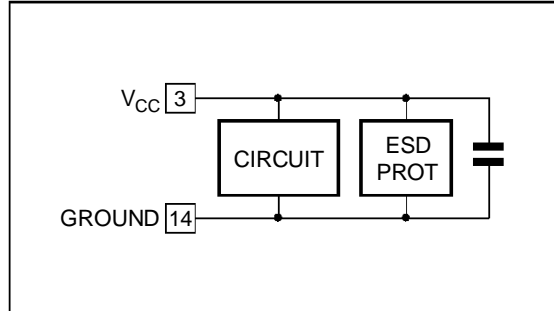

6400-07.EPS

Pins 2-15-16-18-19-20 Video Outputs and PVcc

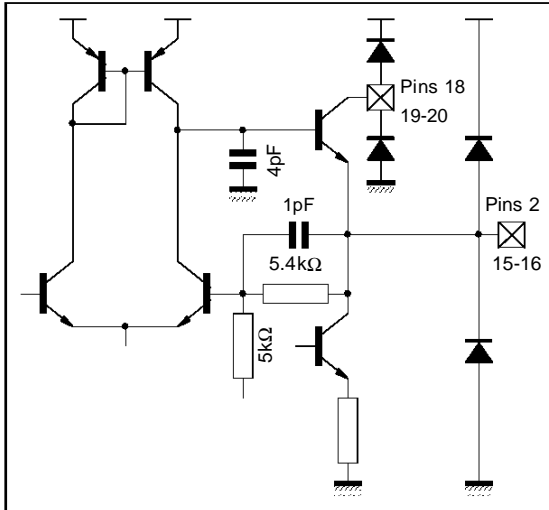

6400-08.EPS

TYPICAL APPLICATION

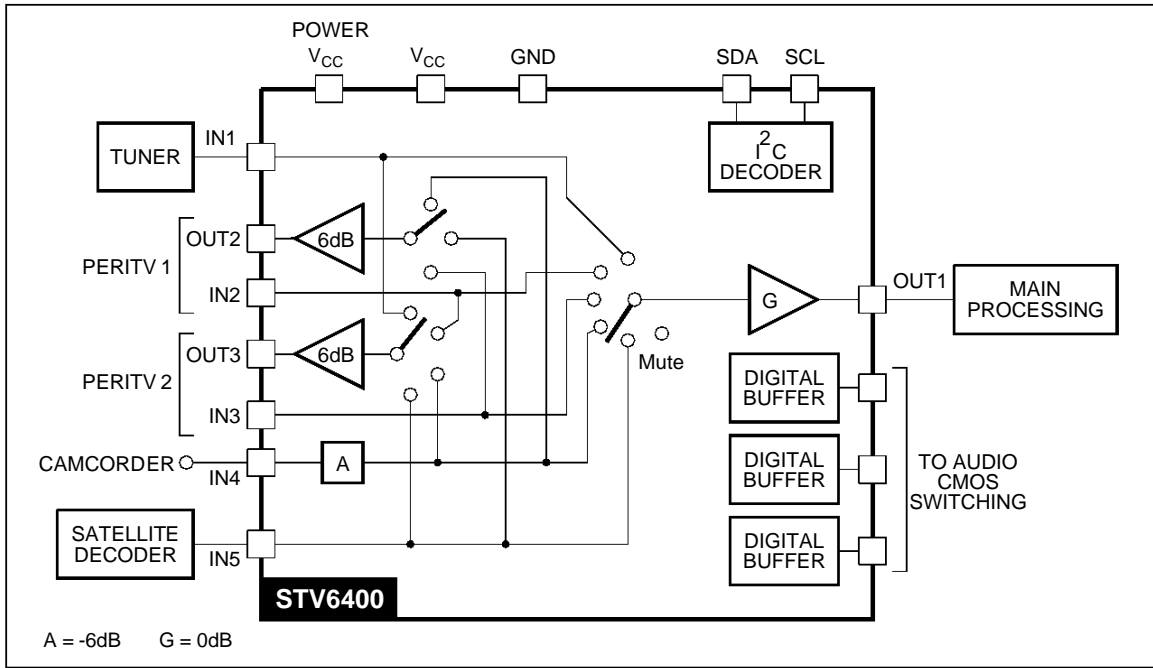

STV6400

PACKAGE MECHANICAL DATA 20 PINS - PLASTIC DIP20 (0.25)

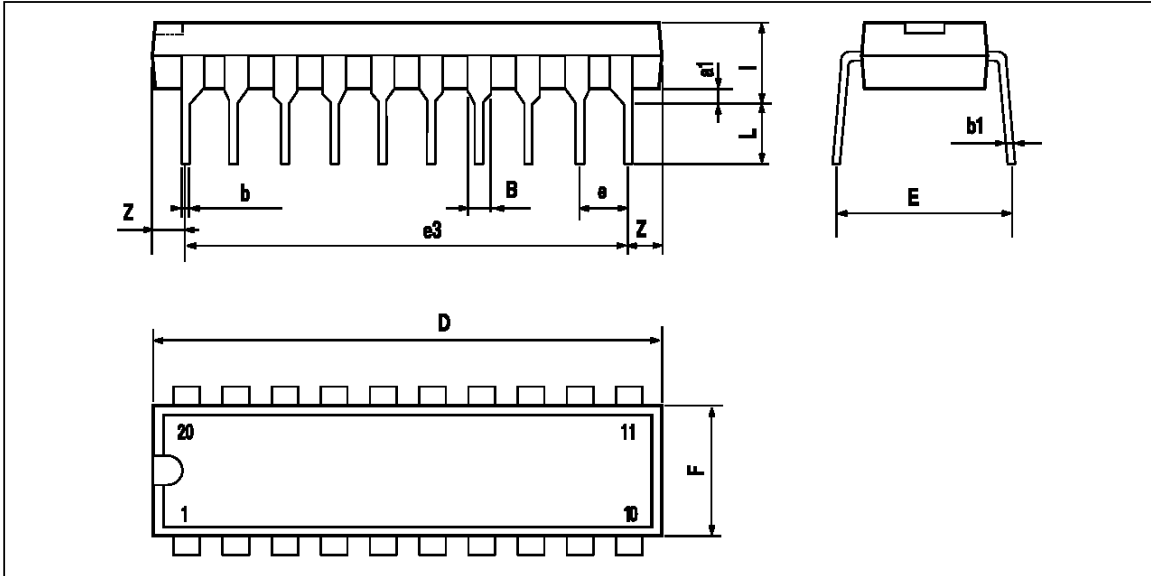

PM-DIP20.EPS

Dimensions	Millimeters			Inches		
	Min.	Typ.	Max.	Min.	Typ.	Max.
a1	0.254			0.010		
B	1.39		1.65	0.055		0.065
b		0.45			0.018	
b1		0.25			0.010	
D			25.4			1.000
E		8.5			0.335	
e		2.54			0.100	
e3		22.86			0.900	
F			7.1			0.280
L			3.93			0.155
L		3.3			0.130	
Z			1.34			0.053

DIP20.TBL

PACKAGE MECHANICAL DATA
20 PINS - PLASTIC MICROPACKAGE (SO)

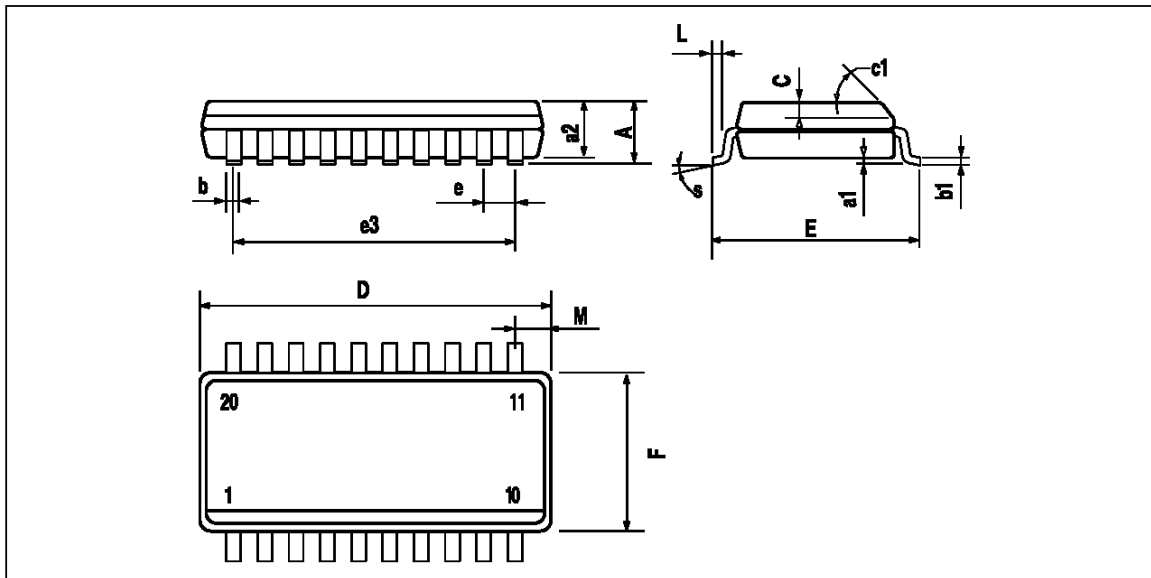

PM-SO20.EPS

Dimensions	Millimeters			Inches		
	Min.	Typ.	Max.	Min.	Typ.	Max.
A			2.65			0.104
a1	0.1		0.3	0.004		0.012
a2			2.45			0.096
b	0.35		0.49	0.014		0.019
b1	0.23		0.32	0.009		0.013
C		0.5			0.020	
c1	45° (typ.)					
D	12.6		13.0	0.496		0.512
E	10		10.65	0.394		0.419
e		1.27			0.050	
e3		11.43			0.450	
F	7.4		7.6	0.291		0.299
L	0.5		1.27	0.020		0.050
M			0.75			0.030
S	8° (Max.)					

SO20.TBL

Information furnished is believed to be accurate and reliable. However, SGS-THOMSON Microelectronics assumes no responsibility for the consequences of use of such information nor for any infringement of patents or other rights of third parties which may result from its use. No licence is granted by implication or otherwise under any patent or patent rights of SGS-THOMSON Microelectronics. Specifications mentioned in this publication are subject to change without notice. This publication supersedes and replaces all information previously supplied. SGS-THOMSON Microelectronics products are not authorized for use as critical components in life support devices or systems without express written approval of SGS-THOMSON Microelectronics.

© 1996 SGS-THOMSON Microelectronics - All Rights Reserved

Purchase of I²C Components of SGS-THOMSON Microelectronics, conveys a license under the Philips I²C Patent. Rights to use these components in a I²C system, is granted provided that the system conforms to the I²C Standard Specifications as defined by Philips.

SGS-THOMSON Microelectronics GROUP OF COMPANIES

Australia - Brazil - Canada - China - France - Germany - Hong Kong - Italy - Japan - Korea - Malaysia - Malta - Morocco
The Netherlands - Singapore - Spain - Sweden - Switzerland - Taiwan - Thailand - United Kingdom - U.S.A.