

DUAL 12V REGULATOR WITH DISABLE

- OUTPUT CURRENTS UP TO 600mA
- FIXED PRECISION OUTPUT 1 VOLTAGE
12V ± 2%
- FIXED PRECISION OUTPUT 2 VOLTAGE
12V ± 2%
- OUTPUT 2 VOLTAGE DISABLED BY A TTL
INPUT
- SHORT CIRCUIT PROTECTION AT BOTH
OUTPUTS
- THERMAL PROTECTION
- LOW DROP OUT 1.5V AT 400mA
- HIGH SUPPLY VOLTAGE REJECTION

DESCRIPTION

The TDA8136 is a monolithic dual positive voltage regulator designed to provide fixed precision output voltages, both 12V at currents up to 600mA.

Output 2 can be disabled by a TTL input. Both output currents are limited by an internal short circuit protection.

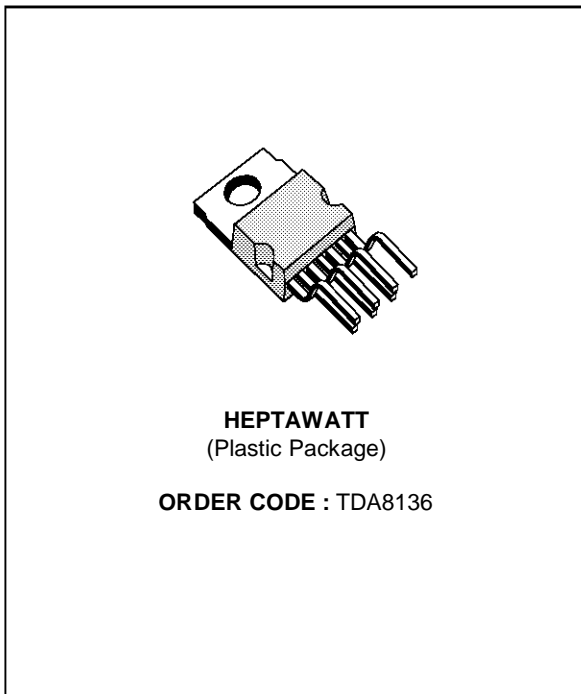

PIN CONNECTIONS

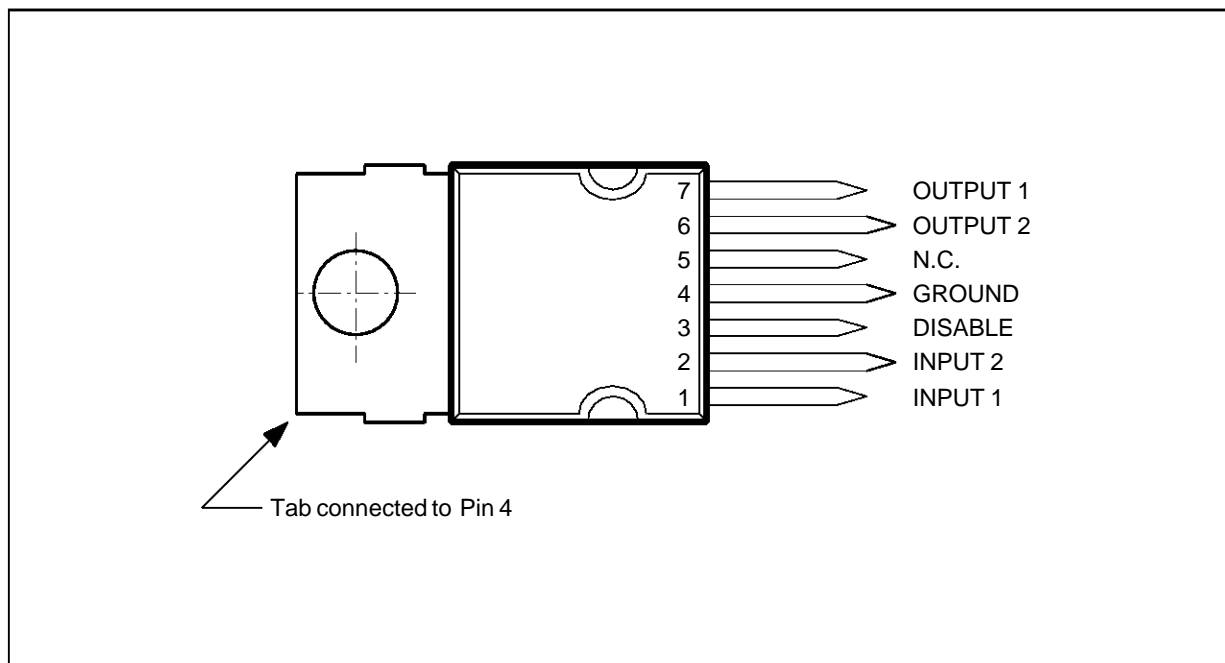

8136-01EPS

BLOCK DIAGRAM

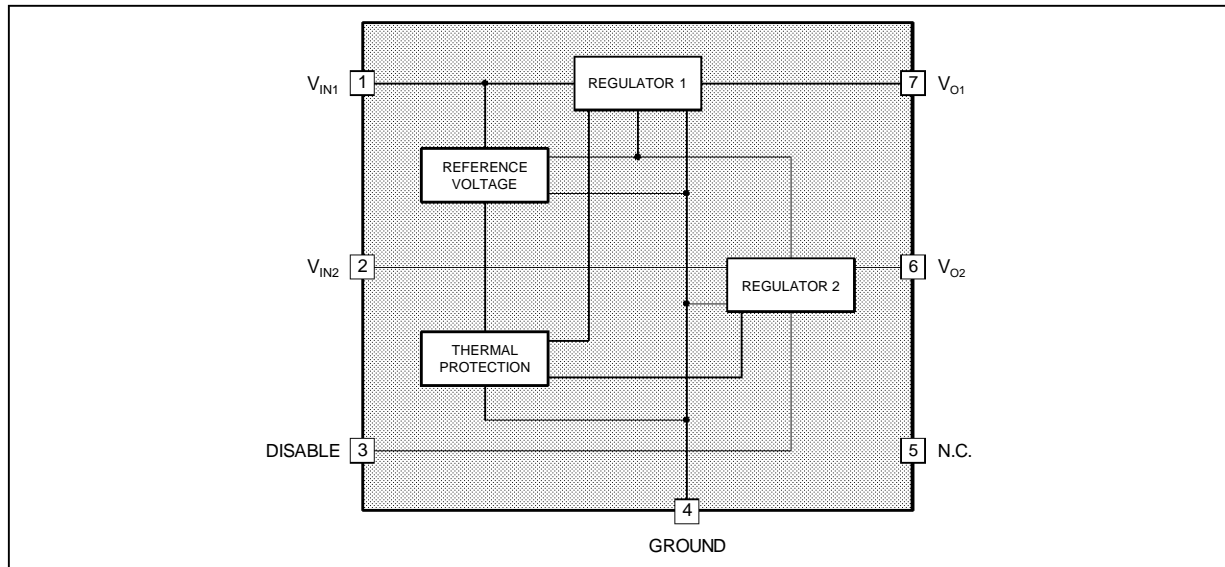

8136-02.EPS

ABSOLUTE MAXIMUM RATINGS

Symbol	Parameter	Value	Unit
$V_{IN1, 2}$	DC Input Voltages	24	V
V_{DIS}	Disable Input Voltage Pin 3	24	V
$I_{O1, 2}$	Output Currents	Internally Limited	
P_t	Power Dissipation	Internally Limited	
T_{STG}	Storage Temperature	- 65 to + 150	°C
T_j	Junction Temperature	0 to + 150	°C

8136-01.TBL

THERMAL DATA

Symbol	Parameter	Value	Unit
$R_{TH(j-c)}$	Thermal Resistance Junction-case Max.	3	°C/W

8136-02.TBL

ELECTRICAL CHARACTERISTICS

($V_{IN1,2} = 14V$; $V_{DIS} = 2.5V$; $I_{O1,2} = 0$; $T_j = 25^{\circ}C$ unless otherwise specified)

Symbol	Parameter	Test Conditions	Min.	Typ.	Max.	Unit
V_{O1}	Output Voltage at Pin 7		11.76	12	12.24	V
V_{O2}	Output Voltage at Pin 6		11.76	12	12.24	V
I_{Q1}	Quiescent Current	$V_{IN2} = 0, V_{DIS} = 0$ $I_{O1} = 10mA$, (see fig. 1)			2	mA
I_{Q2}	Quiescent Current	$I_{O2} = 10mA$ (see fig. 1)			2	mA
$V_{IN1}-V_{O1}$	Drop Out Voltage 1	$I_{O1} = 400mA$			1.5	V
$V_{IN2}-V_{O2}$	Drop Out Voltage 2	$I_{O2} = 400mA$			1.5	V
ΔV_{O1LI}	Line Regulation 1	$14V < V_{IN1} < 18V, I_{O1} = 200mA$			120	mV
ΔV_{O2LI}	Line Regulation 2	$14V < V_{IN2} < 18V, I_{O2} = 200mA$			120	mV
ΔV_{O1LO}	Load Regulation 1	$0 < I_{O1} < 600mA$			240	mV
ΔV_{O2LO}	Load Regulation 2	$0 < I_{O2} < 600mA$			240	mV

8136-03.TBL

ELECTRICAL CHARACTERISTICS (continued)

($V_{IN1,2} = 14V$; $V_{DIS} = 2.5V$; $I_{O1,2} = 0$; $T_j = 25^{\circ}C$ unless otherwise specified)

Symbol	Parameter	Test Conditions	Min.	Typ.	Max.	Unit
I_{O1SC}	Short Circuit Current 1	$14V < V_{IN1} < 18V$			1.3	A
I_{O2SC}	Short Circuit Current 2	$14V < V_{IN2} < 18V$			1.3	A
V_{DISH}	Disable Voltage HIGH at Pin 3		2			V
V_{DISL}	Disable Voltage LOW at Pin 3				0.8	V
I_{DISH}	Bias Current at Pin 3	$V_{DIS} = 5.3V$			10	μA
I_{DISL}	Bias Current at Pin 3	$V_{DIS} = 0.4V$	-80			μA
SVR_1	Supply Voltage Rejection 1 (see note 1)	$V_{IN1} = 16V_{DC} + 1V_{PP} SIN$ $f = 120Hz, I_{O1} = 200mA$	50			dB
SVR_2	Supply Voltage Rejection2 (see note 1)	$V_{IN2} = 16V_{DC} + 1V_{PP} SIN$ $f = 120Hz, I_{O2} = 200mA$	50			dB
I_Q	Quiescent Current	$V_{IN1} = V_{IN2} = 14V_{DC}$ $I_{O1} = I_{O2} = 200mA$ (see fig. 1)			6	mA
T_{JSD}	Thermal Shut-down Junction Temperature			145		$^{\circ}C$

8136-04.TBL

Note 1 : SVR supply voltage rejection :

$$20 \cdot \text{LOG} \cdot \left| \frac{V_{INac}}{V_{Oac}} \right|$$

where :

V_{INac} is the value of the sinusoidal signal forced at the input. (120Hz, 1V_{PP})

V_{Oac} is the peak-peak ripple voltage present at the output

Figure 1 : Test Circuit

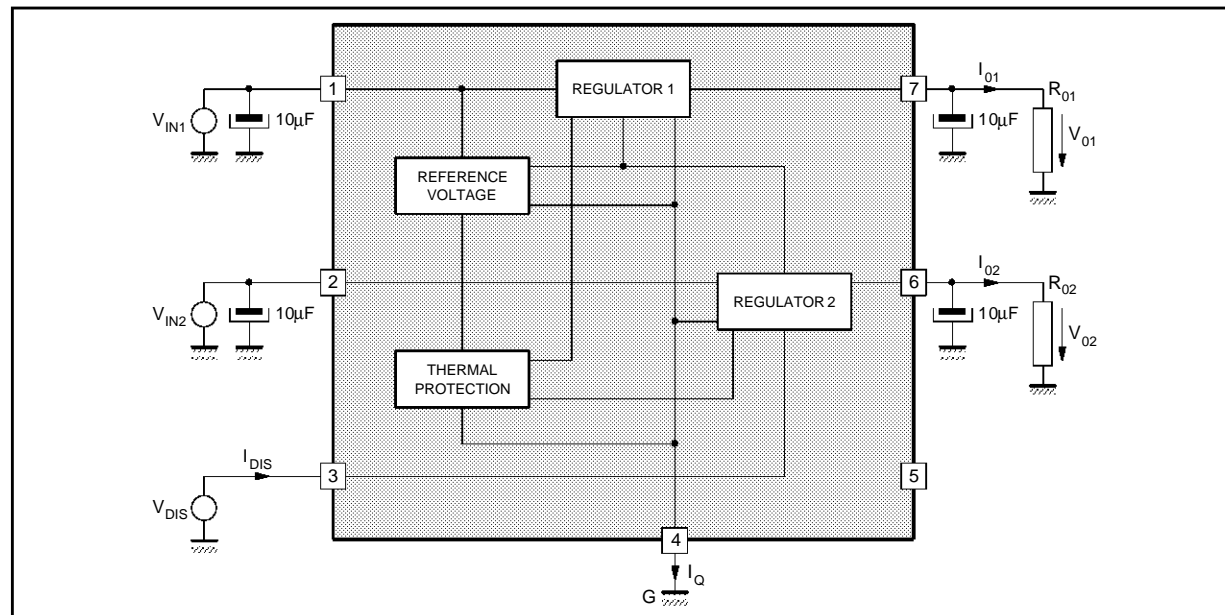

8136-03.EPS

TDA8136

CIRCUIT DESCRIPTION

The TDA8136 is a dual voltage regulator with disable.

The two regulation parts are supplied from one voltage reference circuit, trimmed by zener zap during EWS test. Since the supply voltage of this

last is connected at Pin 1 (V_{IN1}), the regulator 2 will not work if the Pin 1 is not supplied.

It is possible to switch-off the output voltage 2 (V_{O2}) by applying at Pin 3 (disable input) a low TTL level.

TYPICAL APPLICATION

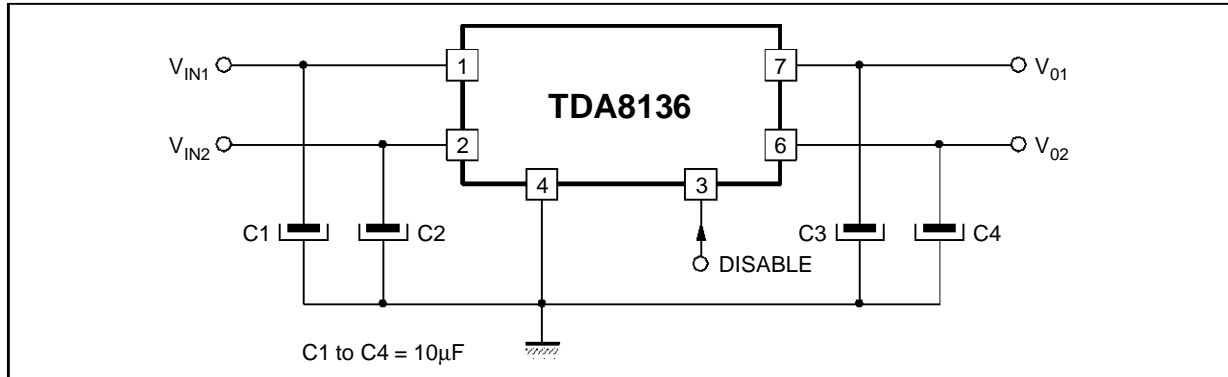

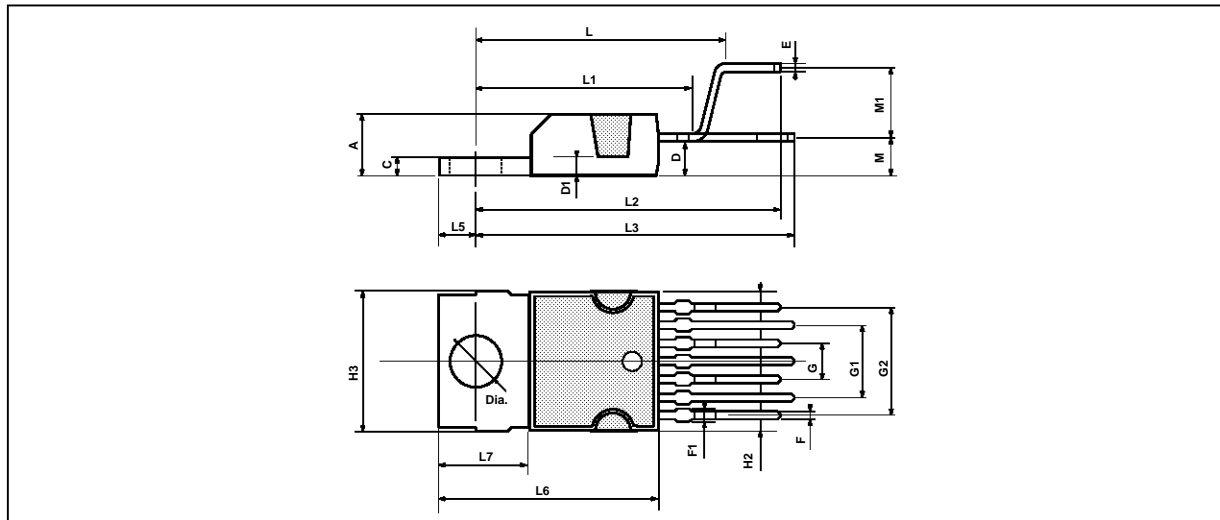
PACKAGE MECHANICAL DATA
9 PINS - PLASTIC HEPTAWATT

PM-HEPTV.EPS

Dimensions	Millimeters			Inches		
	Min.	Typ.	Max.	Min.	Typ.	Max.
A			4.8			0.189
C			1.37			0.054
D	2.4		2.8	0.094		0.110
D1	1.2		1.35	0.047		0.053
E	0.35		0.55	0.014		0.022
F	0.6		0.8	0.024		0.031
F1			0.9			0.035
G	2.41	2.54	2.67	0.095	0.100	0.105
G1	4.91	5.08	5.21	0.193	0.200	0.205
G2	7.49	7.62	7.8	0.295	0.300	0.307
H2			10.4			0.409
H3	10.05		10.4	0.396		0.409
L		16.97			0.668	
L1		14.92			0.587	
L2		21.54			0.848	
L3		22.62			0.891	
L5	2.6		3	0.102		0.118
L6	15.1		15.8	0.594		0.622
L7	6		6.6	0.236		0.260
M		2.8			0.110	
M1		5.08			0.200	
Dia.	3.65		3.85	0.144		0.152

HEPTV.TBL

Information furnished is believed to be accurate and reliable. However, SGS-THOMSON Microelectronics assumes no responsibility for the consequences of use of such information nor for any infringement of patents or other rights of third parties which may result from its use. No licence is granted by implication or otherwise under any patent or patent rights of SGS-THOMSON Microelectronics. Specifications mentioned in this publication are subject to change without notice. This publication supersedes and replaces all information previously supplied. SGS-THOMSON Microelectronics products are not authorized for use as critical components in life support devices or systems without express written approval of SGS-THOMSON Microelectronics.

© 1994 SGS-THOMSON Microelectronics - All Rights Reserved

Purchase of I²C Components of SGS-THOMSON Microelectronics, conveys a license under the Philips I²C Patent. Rights to use these components in a I²C system, is granted provided that the system conforms to the I²C Standard Specifications as defined by Philips.

SGS-THOMSON Microelectronics GROUP OF COMPANIES

Australia - Brazil - China - France - Germany - Hong Kong - Italy - Japan - Korea - Malaysia - Malta - Morocco
The Netherlands - Singapore - Spain - Sweden - Switzerland - Taiwan - Thailand - United Kingdom - U.S.A.