

- Members of the Texas Instruments *Widebus™* Family
- Inputs Are TTL-Voltage Compatible
- Flow-Through Architecture Optimizes PCB Layout
- Distributed V_{CC} and GND Pin Configuration Minimizes High-Speed Switching Noise
- *EPIC™* (Enhanced-Performance Implanted CMOS) 1- μ m Process
- 500-mA Typical Latch-Up Immunity at 125°C
- Package Options Include Plastic 300-mil Shrink Small-Outline (DL) Packages Using 25-mil Center-to-Center Pin Spacings and 380-mil Fine-Pitch Ceramic Flat (WD) Packages Using 25-mil Center-to-Center Pin Spacings

description

The 'ACT16657 contain two noninverting octal transceiver sections with separate parity generator/checker circuits and control signals. For either section, the transmit/receive (1T/R or 2T/R) input determines the direction of data flow. When 1T/R (or 2T/R) is high, data flows from the 1A (or 2A) port to the 1B (or 2B) port (transmit mode); when 1T/R (or 2T/R) is low, data flows from the 1B (or 2B) port to the 1A (or 2A) port (receive mode). When the output-enable (1OE or 2OE) input is high, both the 1A (or 2A) and 1B (or 2B) ports are in the high-impedance state.

Odd or even parity is selected by a logic high or low level, respectively, on the 1ODD/EVEN (or 2ODD/EVEN) input. 1PARITY (or 2PARITY) carries the parity bit value; it is an output from the parity generator/checker in the transmit mode and an input to the parity generator/checker in the receive mode.

In the transmit mode, after the 1A (or 2A) bus is polled to determine the number of high bits, 1PARITY (or 2PARITY) is set to the logic level that maintains the parity sense selected by the level at the 1ODD/EVEN (or 2ODD/EVEN) input. For example, if 1ODD/EVEN is low (even parity selected) and there are five high bits on the 1A bus, then 1PARITY is set to the logic high level so that an even number of the nine total bits (eight 1A-bus bits plus parity bit) are high.

54ACT16657 . . . WD PACKAGE
74ACT16657 . . . DL PACKAGE
(TOP VIEW)

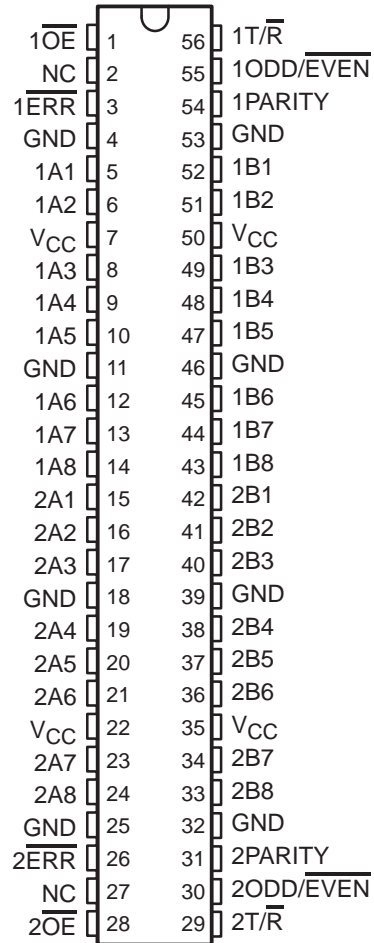

NC – No internal connection



Please be aware that an important notice concerning availability, standard warranty, and use in critical applications of Texas Instruments semiconductor products and disclaimers thereto appears at the end of this data sheet.

EPIC and Widebus are trademarks of Texas Instruments Incorporated.

UNLESS OTHERWISE NOTED this document contains PRODUCTION DATA information current as of publication date. Products conform to specifications per the terms of Texas Instruments standard warranty. Production processing does not necessarily include testing of all parameters.



54ACT16657, 74ACT16657
16-BIT TRANSCEIVERS
WITH PARITY GENERATORS/CHECKERS AND 3-STATE OUTPUTS

SCAS164A – JANUARY 1991 – REVISED APRIL 1996

description (continued)

In the receive mode, after the 1B (or 2B) bus is polled to determine the number of high bits, the $1\overline{ERR}$ (or $2\overline{ERR}$) output logic level indicates whether or not the data to be received exhibits the correct parity sense. For example, if $1ODD/\overline{EVEN}$ is high (odd parity selected), $1PARITY$ is high, and there are three high bits on the 1B bus, then $1\overline{ERR}$ is low, indicating a parity error.

The 74ACT16657 is packaged in TI's shrink small-outline package, which provides twice the I/O pin count and functionality of standard small-outline packages in the same printed-circuit-board area.

The 54ACT16657 is characterized for operation over the full military temperature range of -55°C to 125°C . The 74ACT16657 is characterized for operation from -40°C to 85°C .

FUNCTION TABLE

NUMBER OF A OR B INPUTS THAT ARE HIGH	INPUTS			INPUT/OUTPUT PARITY	OUTPUTS	
	\overline{OE}	$\overline{T/R}$	ODD/\overline{EVEN}		\overline{ERR}	OUTPUT MODE
0, 2, 4, 6, 8	L	H	H	H	Z	Transmit
	L	H	L	L	Z	Transmit
	L	L	H	H	H	Receive
	L	L	H	L	L	Receive
	L	L	L	H	L	Receive
	L	L	L	L	H	Receive
1, 3, 5, 7	L	H	H	L	Z	Transmit
	L	H	L	H	Z	Transmit
	L	L	H	H	L	Receive
	L	L	H	L	H	Receive
	L	L	L	H	H	Receive
	L	L	L	L	L	Receive
Don't care	H	X	X	Z	Z	Z



54ACT16657, 74ACT16657
16-BIT TRANSCEIVERS
WITH PARITY GENERATORS/CHECKERS AND 3-STATE OUTPUTS

SCAS164A – JANUARY 1991 – REVISED APRIL 1996

logic symbol†

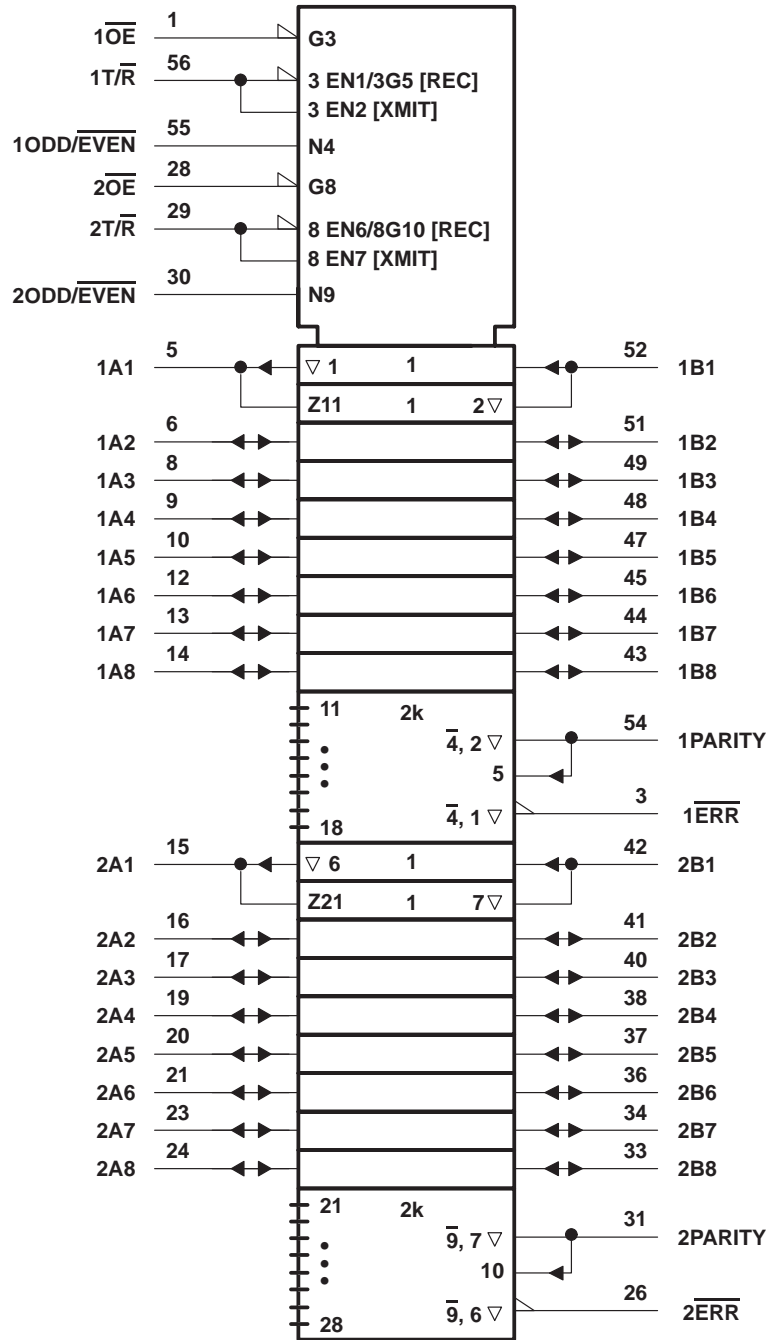

† This symbol is in accordance with ANSI/IEEE Std 91-1984 and IEC Publication 617-12.

54ACT16657, 74ACT16657
16-BIT TRANSCEIVERS
WITH PARITY GENERATORS/CHECKERS AND 3-STATE OUTPUTS

SCAS164A – JANUARY 1991 – REVISED APRIL 1996

logic diagram, each transceiver (positive logic)

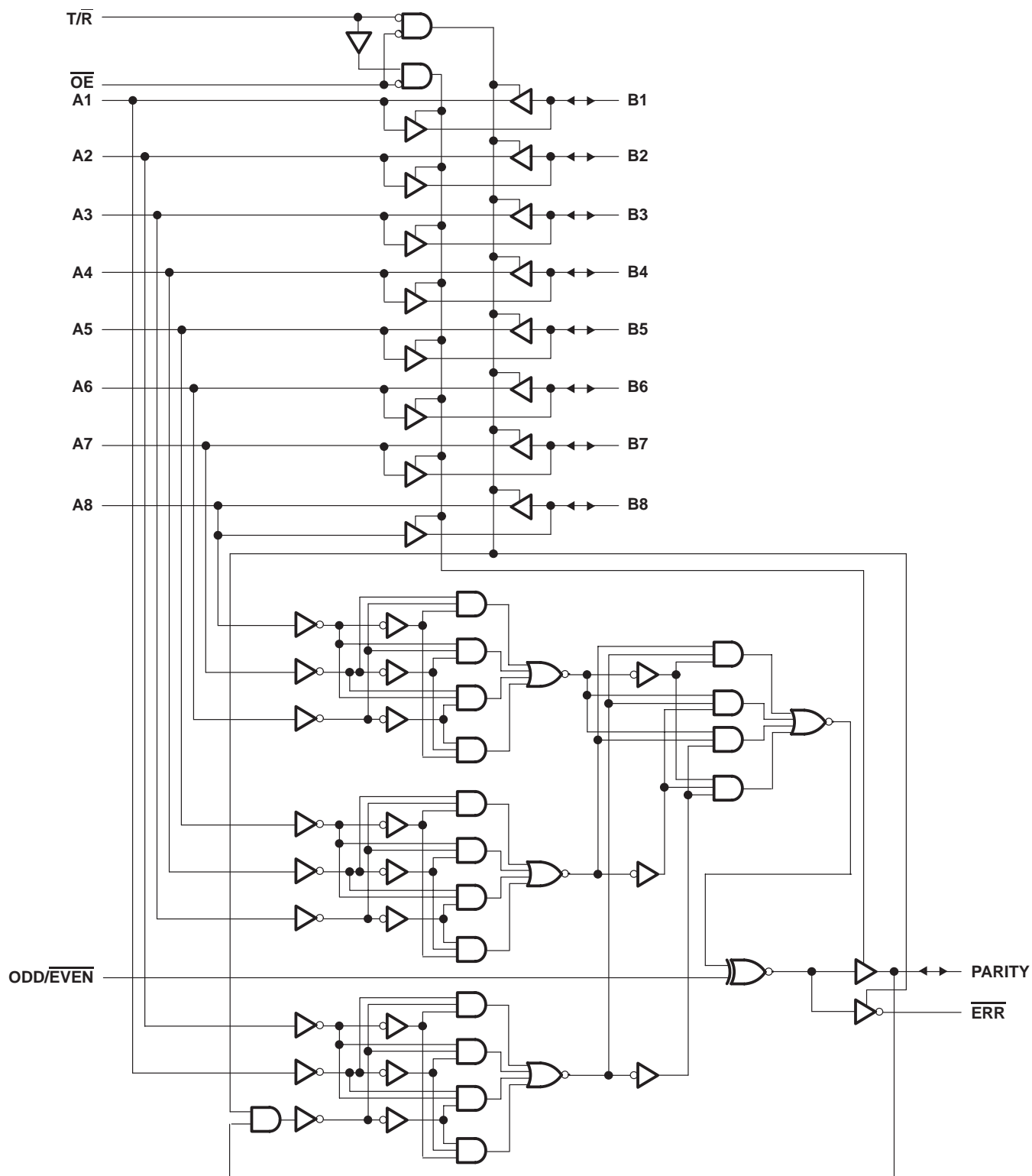

54ACT16657, 74ACT16657
16-BIT TRANSCEIVERS
WITH PARITY GENERATORS/CHECKERS AND 3-STATE OUTPUTS

SCAS164A – JANUARY 1991 – REVISED APRIL 1996

absolute maximum ratings over operating free-air temperature range (unless otherwise noted)†

Supply voltage range, V_{CC}	–0.5 V to 7 V
Input voltage range, V_I (see Note 1)	–0.5 V to $V_{CC} + 0.5$ V
Output voltage range, V_O (see Note 1)	–0.5 V to $V_{CC} + 0.5$ V
Input clamp current, I_{IK} ($V_I < 0$ or $V_I > V_{CC}$)	±20 mA
Output clamp current, I_{OK} ($V_O < 0$ or $V_O > V_{CC}$)	±50 mA
Continuous output current, I_O ($V_O = 0$ to V_{CC})	±50 mA
Continuous current through V_{CC} or GND	±500 mA
Maximum package power dissipation at $T_A = 55^\circ\text{C}$ (in still air) (see Note 2): DL package	1.4 W
Storage temperature range, T_{stg}	–65°C to 150°C

† Stresses beyond those listed under “absolute maximum ratings” may cause permanent damage to the device. These are stress ratings only, and functional operation of the device at these or any other conditions beyond those indicated under “recommended operating conditions” is not implied. Exposure to absolute-maximum-rated conditions for extended periods may affect device reliability.

- NOTES: 1. The input and output voltage ratings may be exceeded if the input and output current ratings are observed.
2. The maximum package power dissipation is calculated using a junction temperature of 150°C and a board trace length of 750 mils.

recommended operating conditions (see Note 3)

	54ACT16657			74ACT16657			UNIT
	MIN	NOM	MAX	MIN	NOM	MAX	
V_{CC} Supply voltage	4.5	5	5.5	4.5	5	5.5	V
V_{IH} High-level input voltage	2			2			V
V_{IL} Low-level input voltage			0.8			0.8	V
V_I Input voltage	0		V_{CC}	0		V_{CC}	V
V_O Output voltage	0		V_{CC}	0		V_{CC}	V
I_{OH} High-level output current			–24			–24	mA
I_{OL} Low-level output current			24			24	mA
$\Delta t/\Delta v$ Input transition rise or fall rate	0		10	0		10	ns/V
T_A Operating free-air temperature	–55		125	–40		85	°C

NOTE 3: Unused inputs must be held high or low to prevent them from floating.

54ACT16657, 74ACT16657
16-BIT TRANSCEIVERS
WITH PARITY GENERATORS/CHECKERS AND 3-STATE OUTPUTS

SCAS164A – JANUARY 1991 – REVISED APRIL 1996

electrical characteristics over recommended operating free-air temperature range (unless otherwise noted)

PARAMETER	TEST CONDITIONS	V _{CC}	T _A = 25°C			54ACT16657		74ACT16657		UNIT
			MIN	TYP	MAX	MIN	MAX	MIN	MAX	
V _{OH}	I _{OH} = -50 μA	4.5 V	4.4			4.4		4.4	V	
		5.5 V	5.4			5.4		5.4		
	I _{OH} = -24 mA	4.5 V	3.94			3.8		3.8		
		5.5 V	4.94			4.8		4.8		
I _{OH} = -75 mA†	5.5 V				3.85		3.85			
V _{OL}	I _{OL} = 50 μA	4.5 V			0.1		0.1	0.1	V	
		5.5 V			0.1		0.1	0.1		
	I _{OL} = 24 mA	4.5 V			0.36		0.44	0.44		
		5.5 V			0.36		0.44	0.44		
I _{OL} = 75 mA†	5.5 V					1.65	1.65			
I _I	A or B ports	V _I = V _{CC} or GND	5.5 V			±0.1		±1	±1	μA
I _{OZ} ‡	Control inputs	V _O = V _{CC} or GND	5.5 V			±0.5		±5	±5	μA
I _{CC}		V _I = V _{CC} or GND, I _O = 0	5.5 V			8		80	80	μA
ΔI _{CC} §		One input at 3.4 V, Other inputs at V _{CC} or GND	5.5 V			0.9		1	1	mA
C _i	Control inputs	V _I = V _{CC} or GND	5 V			4.5				pF
C _O	$\overline{\text{ERR}}$	V _O = V _{CC} or GND	5 V			11				pF
C _{io}	A or B ports	V _O = V _{CC} or GND	5 V			12				pF

† Not more than one output should be tested at a time, and the duration of the test should not exceed 10 ms.

‡ For I/O ports, the parameter I_{OZ} includes the input leakage current.

§ This is the increase in supply current for each input that is at one of the specified TTL voltage levels rather than 0 V or V_{CC}.

switching characteristics over recommended operating free-air temperature range, V_{CC} = 5 V ± 0.5 V (unless otherwise noted) (see Figure 1)

PARAMETER	FROM (INPUT)	TO (OUTPUT)	T _A = 25°C			54ACT16657		74ACT16657		UNIT
			MIN	TYP	MAX	MIN	MAX	MIN	MAX	
t _{PLH}	A or B	B or A	4.1	7.3	9.6	4.1	10.7	4.1	10.7	ns
t _{PHL}			3.2	6.8	9.8	3.2	10.6	3.2	10.6	
t _{PLH}	A	PARITY	4	8.6	12.9	4	14.3	4	14.3	ns
t _{PHL}			4.3	9	13.1	4.3	14.3	4.3	14.3	
t _{PLH}	ODD/ $\overline{\text{EVEN}}$	PARITY, $\overline{\text{ERR}}$	3.7	8.3	12.3	3.7	13.7	3.7	13.7	ns
t _{PHL}			4.1	8.8	12.8	4.1	14.1	4.1	14.1	
t _{PLH}	B	$\overline{\text{ERR}}$	3.9	8.6	13	3.9	14.6	3.9	14.6	ns
t _{PHL}			4.3	9	13.3	4.3	14.7	4.3	14.7	
t _{PLH}	PARITY	$\overline{\text{ERR}}$	3.8	8.4	12.2	3.8	13.8	3.8	13.8	ns
t _{PHL}			4.1	8	12.8	4.1	14.2	4.1	14.2	
t _{PZH}	$\overline{\text{OE}}$	A, B, PARITY, or $\overline{\text{ERR}}$	2.6	6.1	10.1	2.6	11.3	2.6	11.3	ns
t _{PZL}			3.2	7.2	11.7	3.2	13	3.2	13	
t _{PHZ}	$\overline{\text{OE}}$	A, B, PARITY, or $\overline{\text{ERR}}$	5.9	8.6	10.5	5.9	11.2	5.9	11.2	ns
t _{PLZ}			5.3	8	9.8	5.3	10.5	5.3	10.5	

PRODUCT PREVIEW information concerns products in the formative or design phase of development. Characteristic data and other specifications are design goals. Texas Instruments reserves the right to change or discontinue these products without notice.



54ACT16657, 74ACT16657
16-BIT TRANSCEIVERS
WITH PARITY GENERATORS/CHECKERS AND 3-STATE OUTPUTS
SCAS164A – JANUARY 1991 – REVISED APRIL 1996

operating characteristics, $V_{CC} = 5\text{ V}$, $T_A = 25^\circ\text{C}$

PARAMETER		TEST CONDITIONS	TYP	UNIT
C_{pd}	Power dissipation capacitance per transceiver	Outputs enabled	76	pF
		Outputs disabled		

PARAMETER MEASUREMENT INFORMATION

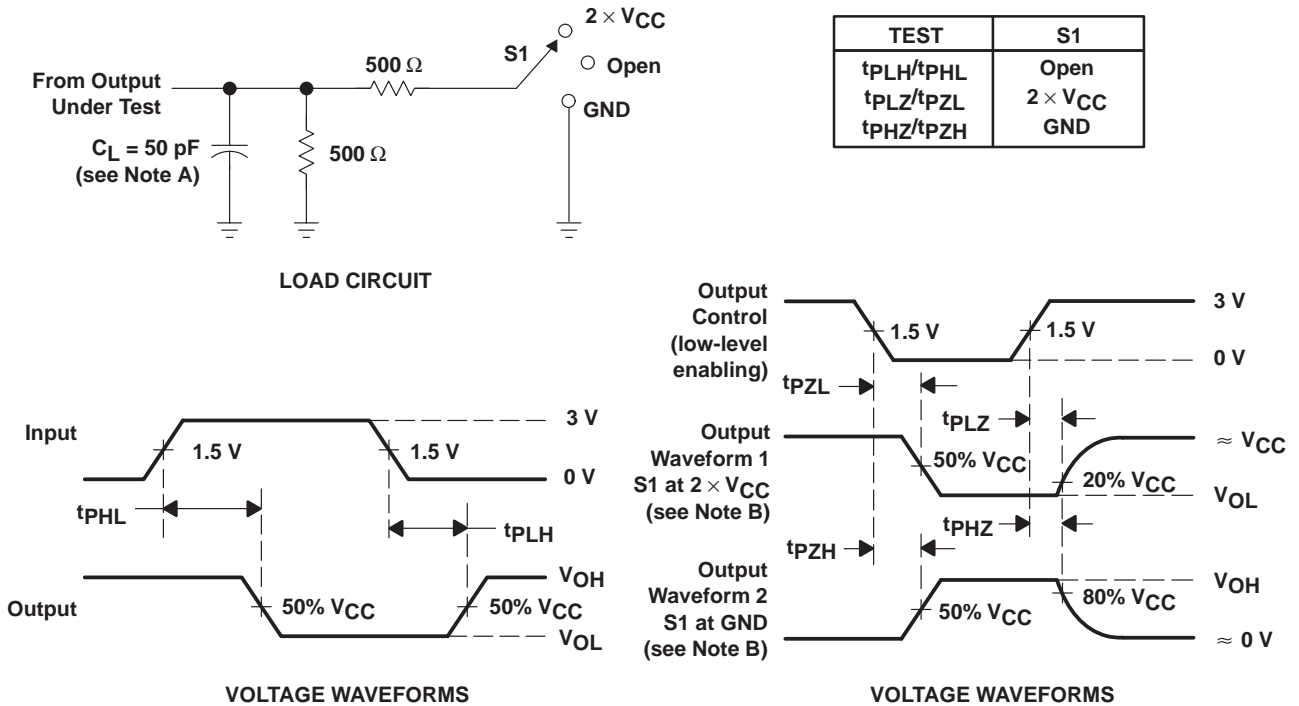

- NOTES: A. C_L includes probe and jig capacitance.
 B. Waveform 1 is for an output with internal conditions such that the output is low except when disabled by the output control. Waveform 2 is for an output with internal conditions such that the output is high except when disabled by the output control.
 C. All input pulses are supplied by generators having the following characteristics: $PRR \leq 1\text{ MHz}$, $Z_O = 50\ \Omega$, $t_r = 3\text{ ns}$, $t_f = 3\text{ ns}$.
 D. The outputs are measured one at a time with one input transition per measurement.

Figure 1. Load Circuit and Voltage Waveforms

IMPORTANT NOTICE

Texas Instruments and its subsidiaries (TI) reserve the right to make changes to their products or to discontinue any product or service without notice, and advise customers to obtain the latest version of relevant information to verify, before placing orders, that information being relied on is current and complete. All products are sold subject to the terms and conditions of sale supplied at the time of order acknowledgement, including those pertaining to warranty, patent infringement, and limitation of liability.

TI warrants performance of its semiconductor products to the specifications applicable at the time of sale in accordance with TI's standard warranty. Testing and other quality control techniques are utilized to the extent TI deems necessary to support this warranty. Specific testing of all parameters of each device is not necessarily performed, except those mandated by government requirements.

CERTAIN APPLICATIONS USING SEMICONDUCTOR PRODUCTS MAY INVOLVE POTENTIAL RISKS OF DEATH, PERSONAL INJURY, OR SEVERE PROPERTY OR ENVIRONMENTAL DAMAGE ("CRITICAL APPLICATIONS"). TI SEMICONDUCTOR PRODUCTS ARE NOT DESIGNED, AUTHORIZED, OR WARRANTED TO BE SUITABLE FOR USE IN LIFE-SUPPORT DEVICES OR SYSTEMS OR OTHER CRITICAL APPLICATIONS. INCLUSION OF TI PRODUCTS IN SUCH APPLICATIONS IS UNDERSTOOD TO BE FULLY AT THE CUSTOMER'S RISK.

In order to minimize risks associated with the customer's applications, adequate design and operating safeguards must be provided by the customer to minimize inherent or procedural hazards.

TI assumes no liability for applications assistance or customer product design. TI does not warrant or represent that any license, either express or implied, is granted under any patent right, copyright, mask work right, or other intellectual property right of TI covering or relating to any combination, machine, or process in which such semiconductor products or services might be or are used. TI's publication of information regarding any third party's products or services does not constitute TI's approval, warranty or endorsement thereof.

Texas Instruments

<http://www.ti.com>

This file is the datasheet for the following electronic components:

74ACT16657 - <http://www.ti.com/product/74act16657?HQS=TI-null-null-dscatalog-df-pf-null-wwe>

74ACT16657DL - <http://www.ti.com/product/74act16657dl?HQS=TI-null-null-dscatalog-df-pf-null-wwe>

74ACT16657DLR - <http://www.ti.com/product/74act16657dlr?HQS=TI-null-null-dscatalog-df-pf-null-wwe>



LittleDiode supplies new, hard to find or obsolete electronic components and semiconductors all over the world.

With over two million different components listed you are sure to find the part you need.

Feel free to visit us today at our online store:

LittleDiode.com

Looking forward to providing you with the best possible service.