HD74AC175

Quad D-Type Flip-Flop

HITACHI

Description

The HD74AC175 is a high-speed quad D flip-flop. The device is useful for general flip-flop requirements where clock and clear inputs are common. The information on the D inputs is stored during the Low-to-High clock transition. Both true and complemented outputs of each flip-flop are provided. A Master Reset input resets all flip-flops, independent of the Clock or D inputs, when Low.

Features

- Edge-Triggered D-Type Inputs
- Buffered Positive Edge-Triggered Clock
- Asynchronous Common Reset
- True and Complement Output
- Outputs Source/Sink 24 mA

HD74AC175

Pin Arrangement

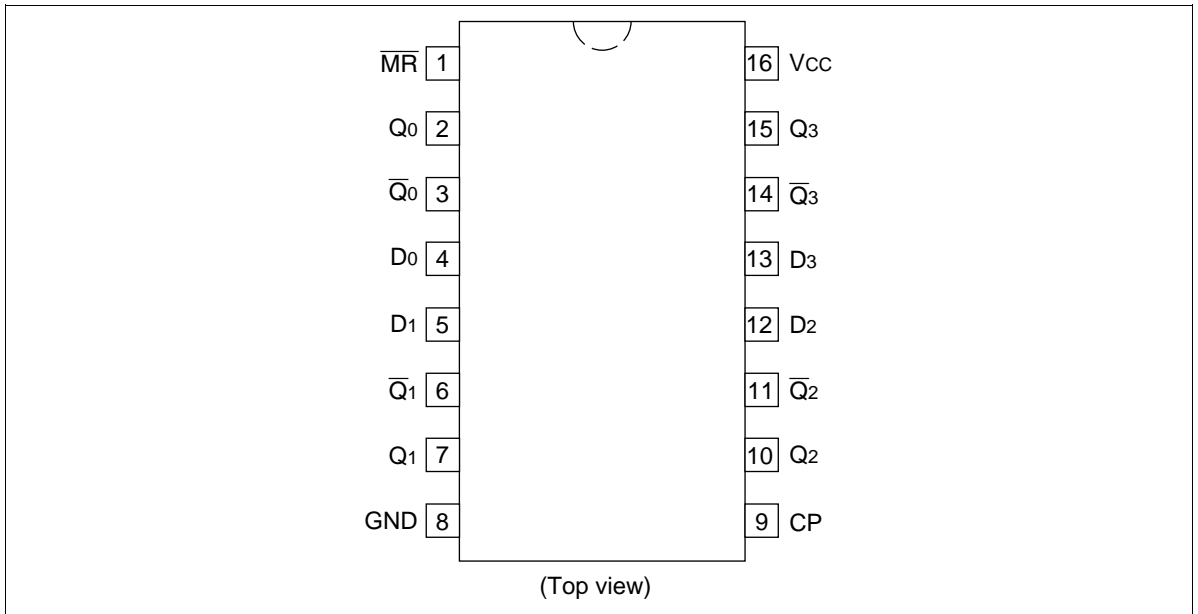

Logic Symbol

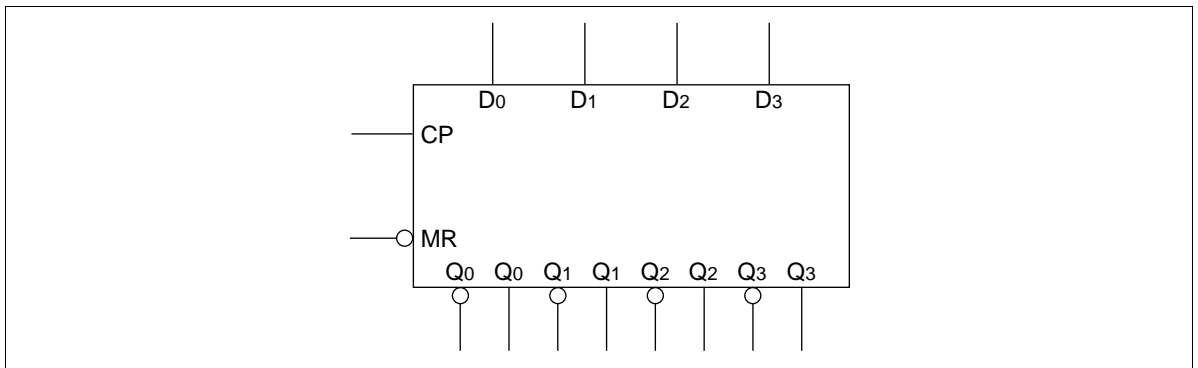

Pin Names

- D₀ to D₃ Data Inputs
- CP Clock Pulse Input
- \overline{MR} Master Reset Input
- Q₀ to Q₃ True Outputs
- \overline{Q}_0 to \overline{Q}_3 Complement Outputs

HITACHI

Functional Description

The HD74AC175 consists of four edge-triggered D flip-flops with individual D inputs and Q and \bar{Q} outputs. The Clock and Master Reset are common. The four flip-flops will store the state of their individual D inputs on the Low-to-High clock (CP) transition, causing individual Q and \bar{Q} outputs to follow. A Low input on the Master Reset (\bar{MR}) will force all Q outputs Low and \bar{Q} outputs High independent of Clock or Data inputs. The HD74AC175 is useful for general logic applications where a common Master Reset and Clock are acceptable.

Truth Table

| Inputs | Outputs | |
|-----------------------|----------------|-------------|
| @ $t_n, \bar{MR} = H$ | @ t_{n+1} | |
| D _n | Q _n | \bar{Q}_n |
| L | L | H |
| H | H | L |

H : High Voltage Level

L : Low Voltage Level

t_n : Bit Time before Clock Pulse

t_{n+1} : Bit Time after Clock Pulse

Logic Diagram

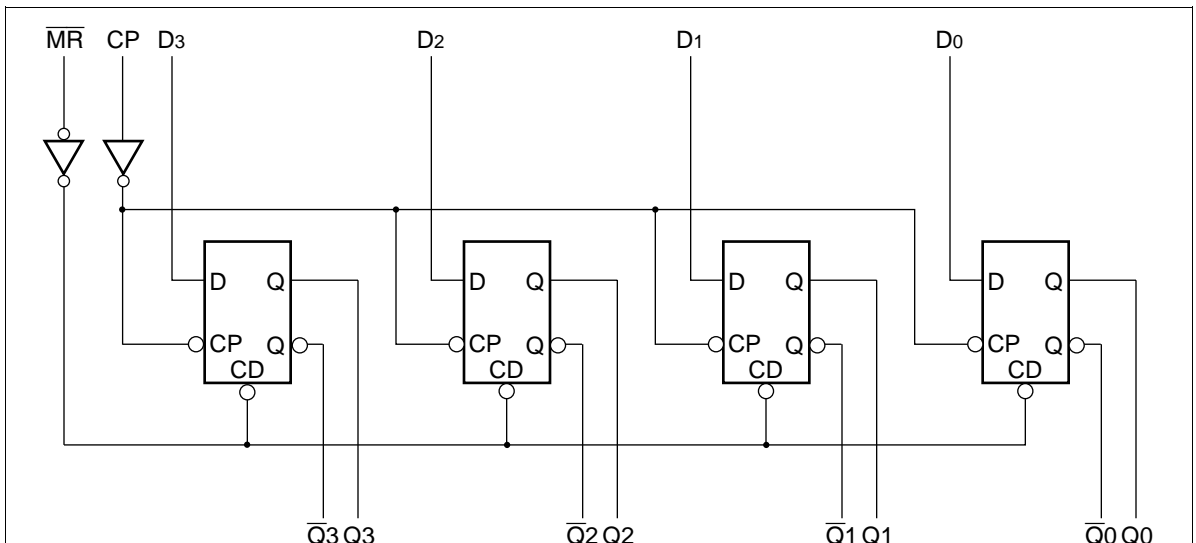

Please note that this diagram is provided only for the understanding of logic operations and should not be used to estimate propagation delays.

HD74AC175

DC Characteristics (unless otherwise specified)

| Item | Symbol | Max | Unit | Condition |
|----------------------------------|----------|-----|---------------|--------------------------------------------------------------------------------------|
| Maximum quiescent supply current | I_{CC} | 80 | μA | $V_{IN} = V_{CC}$ or ground, $V_{CC} = 5.5 \text{ V}$, $T_a = \text{Worst case}$ |
| Maximum quiescent supply current | I_{CC} | 8.0 | μA | $V_{IN} = V_{CC}$ or ground, $V_{CC} = 5.5 \text{ V}$, $T_a = 25^\circ\text{C}$ |

AC Characteristics

| Item | Symbol | $V_{CC} \text{ (V)}^{*1}$ | $T_a = +25^\circ\text{C}$ $C_L = 50 \text{ pF}$ | | | $T_a = -40^\circ\text{C to } +85^\circ\text{C}$ $C_L = 50 \text{ pF}$ | | Unit |
|---------------------------------------|------------------|---------------------------|----------------------------------------------------|-----|------|--------------------------------------------------------------------------|------|------|
| | | | Min | Typ | Max | Min | Max | |
| Maximum clock frequency | f_{max} | 3.3 | 149 | — | — | 139 | — | MHz |
| | | 5.0 | 187 | — | — | 187 | — | |
| Propagation delay | t_{PLH} | 3.3 | 1.0 | 9.5 | 12.0 | 1.0 | 13.5 | ns |
| CP to Q_n or \bar{Q}_n | | 5.0 | 1.0 | 7.0 | 9.0 | 1.0 | 9.5 | |
| Propagation delay | t_{PHL} | 3.3 | 1.0 | 8.5 | 13.0 | 1.0 | 14.5 | ns |
| CP to Q_n or \bar{Q}_n | | 5.0 | 1.0 | 6.0 | 9.5 | 1.0 | 10.5 | |
| Propagation delay | t_{PLH} | 3.3 | 1.0 | 7.5 | 12.5 | 1.0 | 13.5 | ns |
| $\overline{\text{MR}}$ to \bar{Q}_n | | 5.0 | 1.0 | 5.5 | 9.0 | 1.0 | 10.0 | |
| Propagation delay | t_{PHL} | 3.3 | 1.0 | 8.5 | 11.0 | 1.0 | 12.5 | ns |
| $\overline{\text{MR}}$ to Q_n | | 5.0 | 1.0 | 6.0 | 8.5 | 1.0 | 9.5 | |

Note: 1. Voltage Range 3.3 is $3.3 \text{ V} \pm 0.3 \text{ V}$
Voltage Range 5.0 is $5.0 \text{ V} \pm 0.5 \text{ V}$

AC Operating Requirements

| Item | Symbol | V _{CC} (V)*1 | Ta = +25°C C _L = 50 pF | | Ta = -40°C to +85°C C _L = 50 pF | |
|--------------------------------------------------|------------------|-----------------------|--------------------------------------|--------------------|--------------------------------------------------|------|
| | | | Typ | Guaranteed Minimum | Guaranteed Minimum | Unit |
| Set-up time, HIGH or LOW D _n to CP | t _{su} | 3.3 | 2.0 | 4.5 | 4.5 | ns |
| | | 5.0 | 1.0 | 3.0 | 3.0 | |
| Hold time, HIGH or LOW D _n to CP | t _h | 3.3 | 0 | 1.0 | 1.0 | ns |
| | | 5.0 | 0 | 1.0 | 1.0 | |
| CP pulse width HIGH or LOW | t _w | 3.3 | 2.5 | 4.5 | 4.5 | ns |
| | | 5.0 | 2.0 | 3.5 | 3.5 | |
| $\overline{\text{MR}}$ pulse width, LOW | t _w | 3.3 | 2.5 | 4.5 | 5.0 | ns |
| | | 5.0 | 2.0 | 3.5 | 3.5 | |
| Recovery time $\overline{\text{MR}}$ to CP | t _{rec} | 3.3 | -2.0 | 0.0 | 0.0 | ns |
| | | 5.0 | -1.0 | 0.0 | 0.0 | |

Note: 1. Voltage Range 3.3 is 3.3 V ± 0.3 V
Voltage Range 5.0 is 5.0 V ± 0.5 V

Capacitance

| Item | Symbol | Typ | Unit | Condition |
|-------------------------------|-----------------|------|------|-------------------------|
| Input capacitance | C _{IN} | 4.5 | pF | V _{CC} = 5.5 V |
| Power dissipation capacitance | C _{PD} | 45.0 | pF | V _{CC} = 5.0 V |

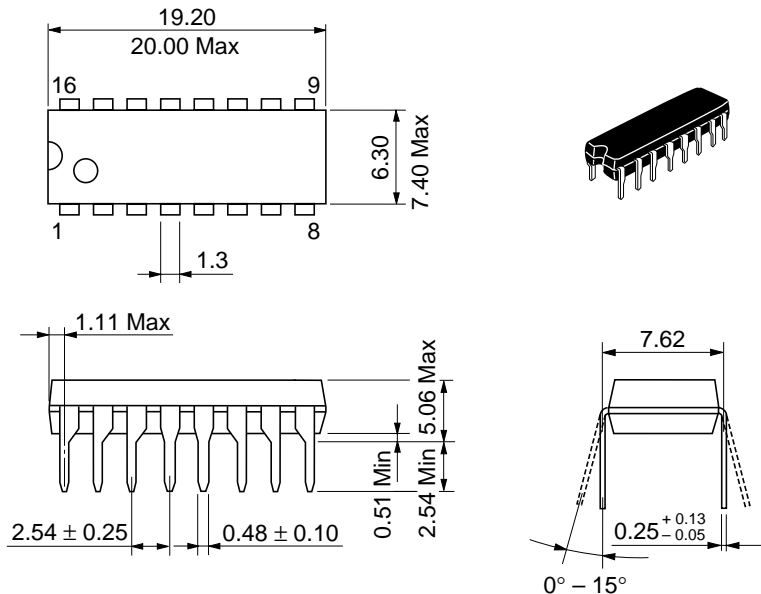

| | |
|--------------------------|----------|
| Hitachi Code | DP-16 |
| JEDEC | Conforms |
| EIAJ | Conforms |
| Weight (reference value) | 1.07 g |

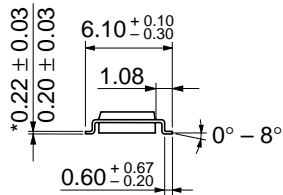
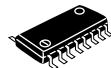
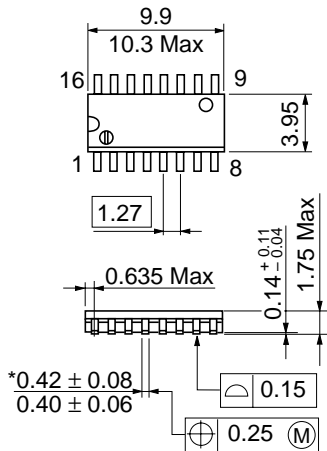

*Dimension including the plating thickness
Base material dimension

| | |
|--------------------------|----------|
| Hitachi Code | FP-16DN |
| JEDEC | Conforms |
| EIAJ | Conforms |
| Weight (reference value) | 0.15 g |

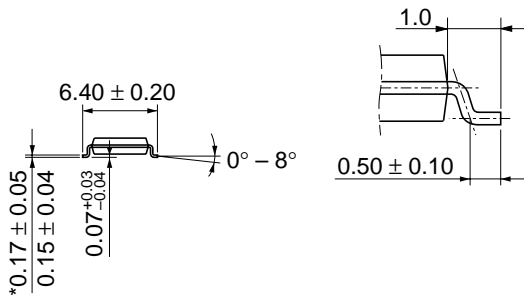
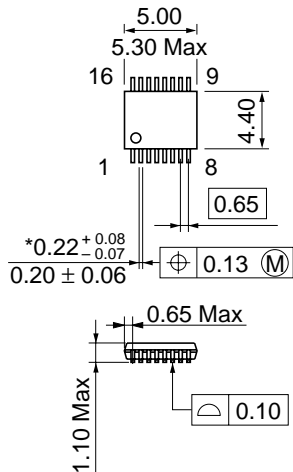

*Dimension including the plating thickness
 Base material dimension

| | |
|--------------------------|----------|
| Hitachi Code | TTP-16DA |
| JEDEC | — |
| EIAJ | — |
| Weight (reference value) | 0.05 g |

Cautions

1. Hitachi neither warrants nor grants licenses of any rights of Hitachi's or any third party's patent, copyright, trademark, or other intellectual property rights for information contained in this document. Hitachi bears no responsibility for problems that may arise with third party's rights, including intellectual property rights, in connection with use of the information contained in this document.
2. Products and product specifications may be subject to change without notice. Confirm that you have received the latest product standards or specifications before final design, purchase or use.
3. Hitachi makes every attempt to ensure that its products are of high quality and reliability. However, contact Hitachi's sales office before using the product in an application that demands especially high quality and reliability or where its failure or malfunction may directly threaten human life or cause risk of bodily injury, such as aerospace, aeronautics, nuclear power, combustion control, transportation, traffic, safety equipment or medical equipment for life support.
4. Design your application so that the product is used within the ranges guaranteed by Hitachi particularly for maximum rating, operating supply voltage range, heat radiation characteristics, installation conditions and other characteristics. Hitachi bears no responsibility for failure or damage when used beyond the guaranteed ranges. Even within the guaranteed ranges, consider normally foreseeable failure rates or failure modes in semiconductor devices and employ systemic measures such as fail-safes, so that the equipment incorporating Hitachi product does not cause bodily injury, fire or other consequential damage due to operation of the Hitachi product.
5. This product is not designed to be radiation resistant.
6. No one is permitted to reproduce or duplicate, in any form, the whole or part of this document without written approval from Hitachi.
7. Contact Hitachi's sales office for any questions regarding this document or Hitachi semiconductor products.

HITACHI

Hitachi, Ltd.

Semiconductor & Integrated Circuits.
Nippon Bldg., 2-6-2, Ohte-machi, Chiyoda-ku, Tokyo 100-0004, Japan
Tel: Tokyo (03) 3270-2111 Fax: (03) 3270-5109

URL North America : <http://semiconductor.hitachi.com/>
Europe : <http://www.hitachi-eu.com/hel/ecg>
Asia (Singapore) : <http://www.has.hitachi.com.sg/grp3/sicd/index.htm>
Asia (Taiwan) : http://www.hitachi.com.tw/E/Product/SICD_Frame.htm
Asia (HongKong) : <http://www.hitachi.com.hk/eng/bo/grp3/index.htm>
Japan : <http://www.hitachi.co.jp/Sicd/indx.htm>

For further information write to:

Hitachi Semiconductor
(America) Inc.
179 East Tasman Drive,
San Jose, CA 95134
Tel: <1> (408) 433-1990
Fax: <1> (408) 433-0223

Hitachi Europe GmbH
Electronic components Group
Dornacher Straße 3
D-85622 Feldkirchen, Munich
Germany
Tel: <49> (89) 9 9180-0
Fax: <49> (89) 9 29 30 00

Hitachi Europe Ltd.
Electronic Components Group.
Whitebrook Park
Lower Cookham Road
Maidenhead
Berkshire SL6 8YA, United Kingdom
Tel: <44> (1628) 585000
Fax: <44> (1628) 778322

Hitachi Asia Pte. Ltd.
16 Collyer Quay #20-00
Hitachi Tower
Singapore 049318
Tel: 535-2100
Fax: 535-1533

Hitachi Asia Ltd.
Taipei Branch Office
3F, Hung Kuo Building, No.167,
Tun-Hwa North Road, Taipei (105)
Tel: <886> (2) 2718-3666
Fax: <886> (2) 2718-8180

Hitachi Asia (Hong Kong) Ltd.
Group III (Electronic Components)
7/F., North Tower, World Finance Centre,
Harbour City, Canton Road, Tsim Sha Tsui,
Kowloon, Hong Kong
Tel: <852> (2) 735 9218
Fax: <852> (2) 730 0281
Telex: 40815 HITEC HX

Copyright ' Hitachi, Ltd., 1999. All rights reserved. Printed in Japan.

HITACHI



LittleDiode supplies new, hard to find or obsolete electronic components and semiconductors all over the world.

With over two million different components listed you are sure to find the part you need.

Feel free to visit us today at our online store:

LittleDiode.com

Looking forward to providing you with the best possible service.