HN58C65 Series

8192-word × 8-bit Electrically Erasable and Programmable CMOS
ROM

HITACHI

ADE-203-374A (Z)

Rev. 1.0

Apr. 12, 1995

Description

The Hitachi HN58C65 is a electrically erasable and programmable ROM organized as 8192-word × 8-bit. It realizes high speed, low power consumption, and a high level of reliability, employing advanced MNOS memory technology and CMOS process and circuitry technology. It also has a 32-byte page programming function to make its erase and write operations faster.

Features

- Single 5 V Supply
- On chip latches: address, data, \overline{CE} , \overline{OE} , \overline{WE}
- Automatic byte write: 10 ms max
- Automatic page write (32 byte): 10 ms max
- Fast access time: 250 ns max
- Low power dissipation: 20 mW/MHz typ (Active)
2.0 mW typ (Standby)
- \overline{Data} polling and Ready/ \overline{Busy}
- Data protection circuitry on power on/power off
- Conforms to JEDEC byte-wide standard
- Reliable CMOS with MNOS cell technology
- 10^5 erase/write cycles (in page mode)
- 10 year data retention

Ordering Information

Type No.	Access Time	Package
HN58C65P-25	250 ns	600 mil 28 pin plastic DIP (DP-28)
HN58C65FP-25	250 ns	28 pin plastic SOP ¹ (FP-28D/DA)

Note: 1. T is added to the end of the type no. for a SOP of 3.0 mm (max) thickness.

HN58C65 Series

Pin Arrangement

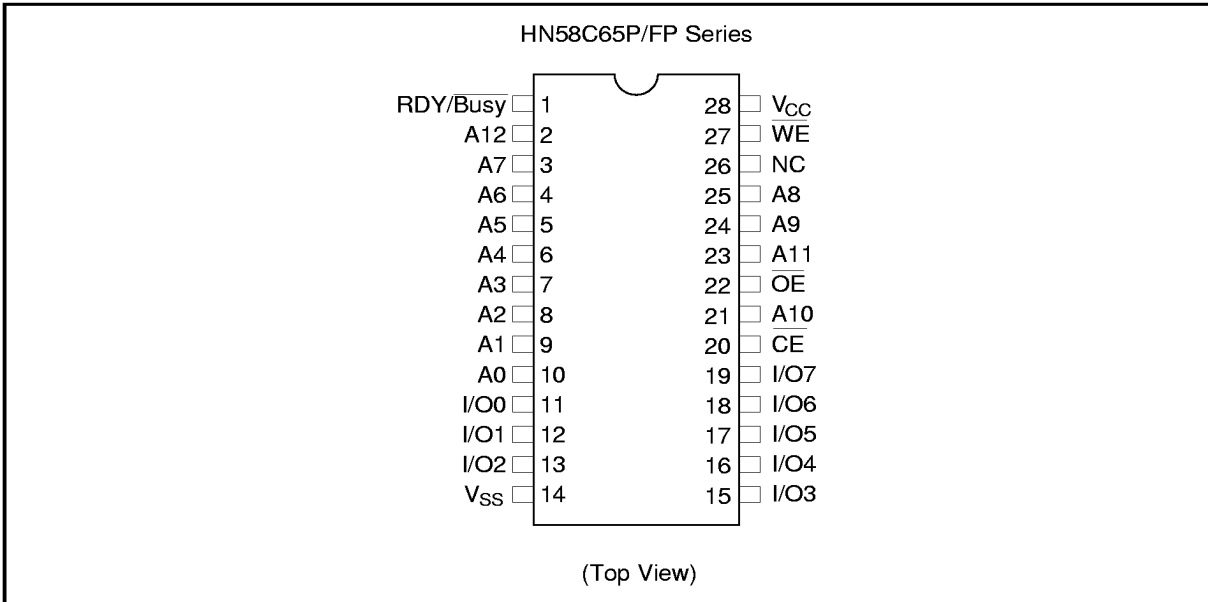

Pin Description

Pin Name	Function
A0 – A12	Address input
I/O1 – I/O7	Data input/output
OE	Output enable
CE	Chip enable
WE	Write enable
V _{CC}	Power (+5 V)
V _{SS}	Ground
NC	No connection
RDY/Busy	Ready/Busy

HITACHI

Block Diagram

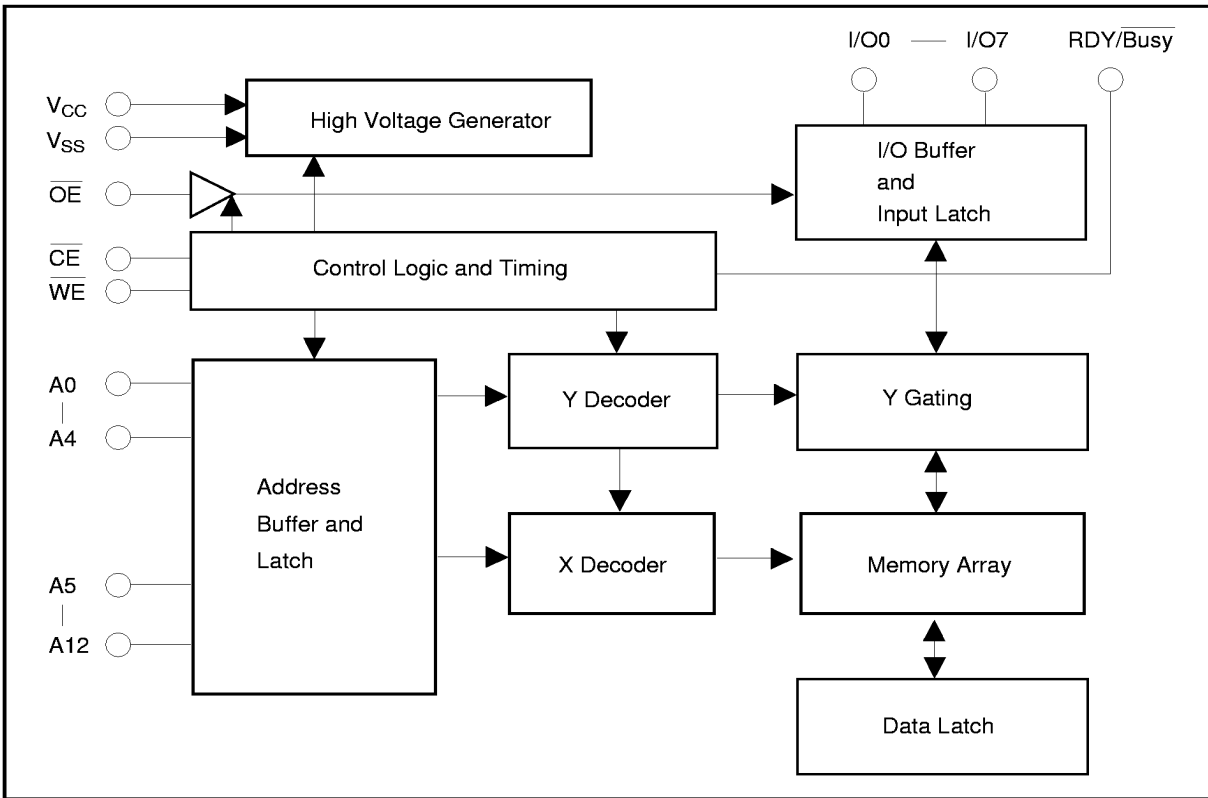

Mode Selection

Pin Mode	\overline{CE}	\overline{OE}	\overline{WE}	RDY/Busy	I/O
Read	V_{IL}	V_{IL}	V_{IH}	High-Z	Dout
Standby	V_{IH}	X^1	X	High-Z	High-Z
Write	V_{IL}	V_{IH}	V_{IL}	High-Z to V_{OL}	Din
Deselect	V_{IL}	V_{IH}	V_{IH}	High-Z	High-Z
Write inhibit	X	X	V_{IH}		
	X	V_{IL}	X	High-Z	—
Data polling	V_{IL}	V_{IL}	V_{IH}	V_{OL}	Data out (I/O7)

Note: 1. X = Don't care

HN58C65 Series

Absolute Maximum Ratings

Parameter	Symbol	Value	Unit
Supply voltage ¹	V _{CC}	-0.6 to +7.0	V
Input voltage ¹	V _{in}	-0.5 ² to +7.0	V
Operating temperature range ³	T _{opr}	0 to +70	°C
Storage temperature range	T _{stg}	-55 to +125	°C

Notes: 1. With respect to V_{SS}

2. -3.0 V for pulse width ≤ 50 ns.

3. Including electrical characteristics and data retention.

Recommended DC Operating Conditions

Parameter	Symbol	Min	Typ	Max	Unit
Supply voltage	V _{CC}	4.5	5.0	5.5	V
Input voltage	V _{IL}	-0.3	—	0.8	V
	V _{IH}	2.2	—	V _{CC} + 1	V
Operating temperature	T _{opr}	0	—	70	°C

HITACHI

4

DC Characteristics ($T_a = 0$ to $+70^\circ\text{C}$, $V_{CC} = 5\text{ V} \pm 10\%$)

Parameter	Symbol	Min	Typ	Max	Unit	Test Conditions
Input leakage current	I_{LI}	—	—	2	μA	$V_{CC} = 5.5\text{ V}$ $V_{in} = 5.5\text{ V}$
Output leakage current	I_{LO}	—	—	2	μA	$V_{CC} = 5.5\text{ V}$ $V_{out} = 5.5/0.4\text{ V}$
V_{CC} current (Standby)	I_{CC1}	—	—	1	mA	$\overline{CE} = V_{IH}$, $\overline{CE} = V_{CC}$
V_{CC} current (Active)	I_{CC2}	—	—	8	mA	$I_{out} = 0\text{ mA}$ Duty = 100% Cycle = 1 μs at $V_{CC} = 5.5\text{ V}$
		—	—	25	mA	$I_{out} = 0\text{ mA}$ Duty = 100% Cycle = 250 ns at $V_{CC} = 5.5\text{ V}$
Input low voltage	V_{IL}	-0.3^{11}	—	0.8	V	
Input high voltage	V_{IH}	2.2	—	$V_{CC} + 1$	V	
Output low voltage	V_{OL}	—	—	0.4	V	$I_{OL} = 2.1\text{ mA}$
Output high voltage	V_{OH}	2.4	—	—	V	$I_{OH} = -400\ \mu\text{A}$

Note: 1. -1.0 V for pulse width $\leq 50\text{ ns}$

Capacitance ($T_a = 25^\circ\text{C}$, $f = 1\text{ MHz}$)

Parameter	Symbol	Min	Typ	Max	Unit	Test Conditions
Input capacitance ¹¹	C_{in}	—	—	6	pF	$V_{in} = 0\text{ V}$
Output capacitance ¹¹	C_{out}	—	—	12	pF	$V_{out} = 0\text{ V}$

Note: 1. This parameter is periodically sampled and not 100% tested.

AC Characteristics ($T_a = 0$ to $+70^\circ\text{C}$, $V_{CC} = 5\text{ V} \pm 10\%$)

Test Conditions

- Input pulse levels: 0.4 V to 2.4 V
- Input rise and fall time: $\leq 20\text{ ns}$
- Output load: 1TTL gate + 100 pF
- Reference levels for measuring timing: 0.8 V and 2 V

HN58C65 Series

Read Cycle

Parameter	Symbol	Min	Max	Unit	Test Conditions
Address to output delay	t_{ACC}	—	250	ns	$\overline{CE} = \overline{OE} = V_{IL}, \overline{WE} = V_{IH}$
\overline{CE} to output delay	t_{CE}	—	250	ns	$\overline{OE} = V_{IL}, \overline{WE} = V_{IH}$
\overline{OE} to output delay	t_{OE}	10	100	ns	$\overline{CE} = V_{IL}, \overline{WE} = V_{IH}$
Address to output hold	t_{OH}	0	—	ns	$\overline{CE} = \overline{OE} = V_{IL}, \overline{WE} = V_{IH}$
$\overline{OE}, \overline{CE}$ high to output float ¹	t_{DF}	0	90	ns	$\overline{CE} = V_{IL}, \overline{WE} = V_{IH}$

Note: 1. t_{DF} is defined at which the outputs achieve the open circuit conditions and are no longer driven.

Read Timing Waveform

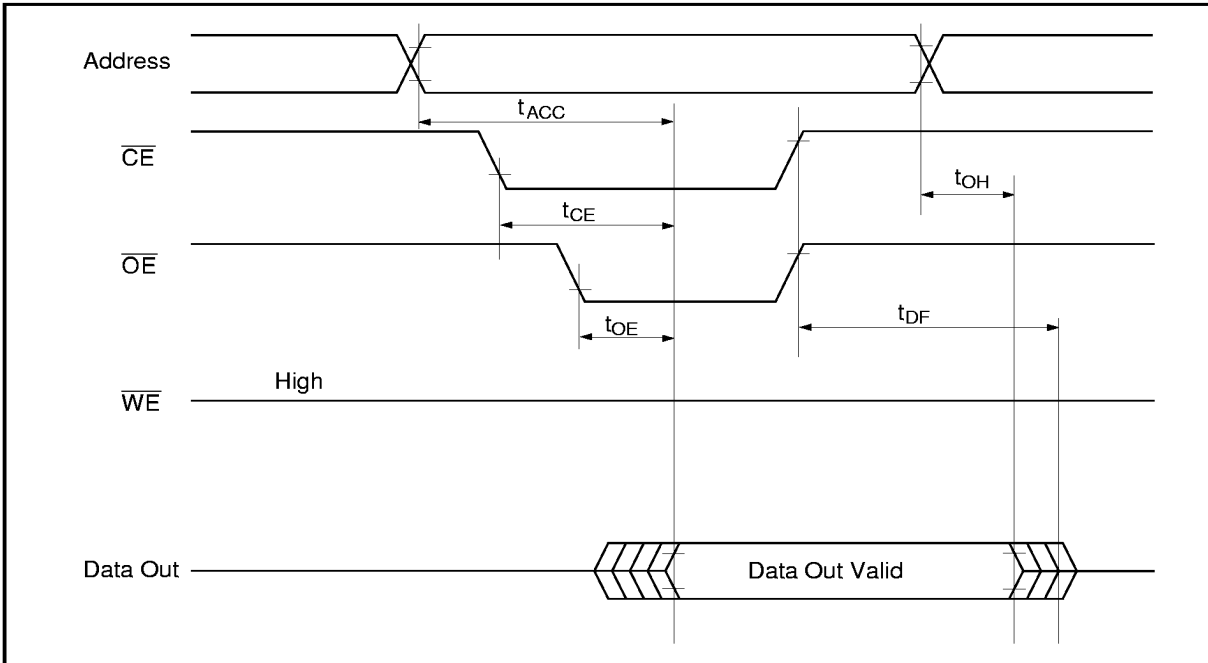

HITACHI

Write Cycle

Parameter	Symbol	Min ¹	Typ	Max	Unit	Test Conditions
Address setup time	t _{AS}	0	—	—	ns	
Address hold time	t _{AH}	150	—	—	ns	
\overline{CE} to write setup time (\overline{WE} controlled)	t _{CS}	0	—	—	ns	
\overline{CE} hold time (\overline{WE} controlled)	t _{CH}	0	—	—	ns	
\overline{WE} to write setup time (\overline{CE} controlled)	t _{WS}	0	—	—	ns	
\overline{WE} hold time (\overline{CE} controlled)	t _{WH}	0	—	—	ns	
\overline{OE} to write setup time	t _{OES}	0	—	—	ns	
\overline{OE} hold time	t _{OEH}	0	—	—	ns	
Data setup time	t _{DS}	100	—	—	ns	
Data hold time	t _{DH}	20	—	—	ns	
\overline{WE} pulse width (\overline{WE} controlled)	t _{WP}	200	—	—	ns	
\overline{CE} pulse width (\overline{CE} controlled)	t _{CW}	200	—	—	ns	
Data latch time	t _{DL}	100	—	—	ns	
Byte lode cycle	t _{BLC}	0.30	—	30	μs	
Byte lode window	t _{BL}	100	—	—	μs	
Write cycle time	t _{WC}	—	—	10 ²	ms	
Time to devce busy	t _{DB}	120	—	—	ns	
Write start time	t _{DW}	150	—	—	ns	

- Notes: 1. Use this device in longer cycle than this value.
 2. t_{WC} must be longer than this value unless polling technique is used. This device automatically completes the internal write operation within this value.

HN58C65 Series

Byte Write Timing Waveform (1) ($\overline{\text{WE}}$ Controlled)

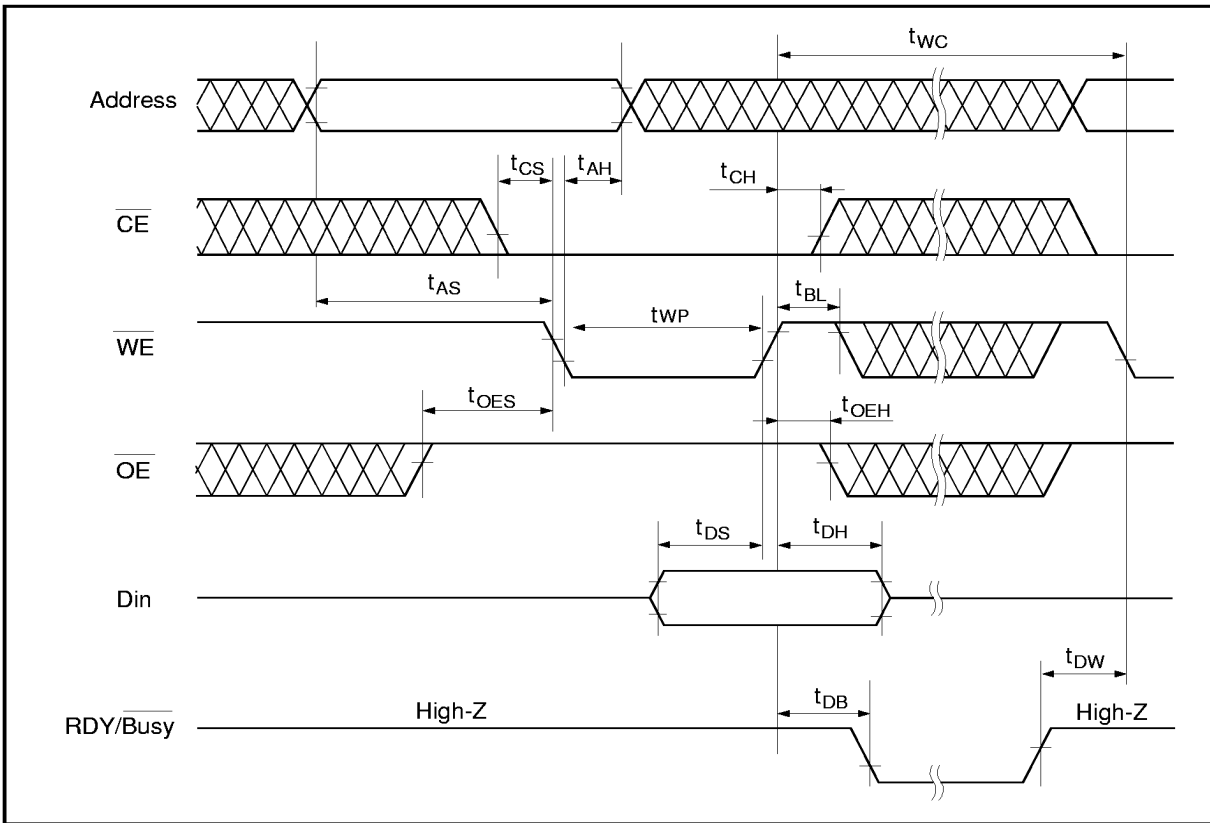

HITACHI

Byte Write Timing Waveform (2) ($\overline{\text{CE}}$ Controlled)

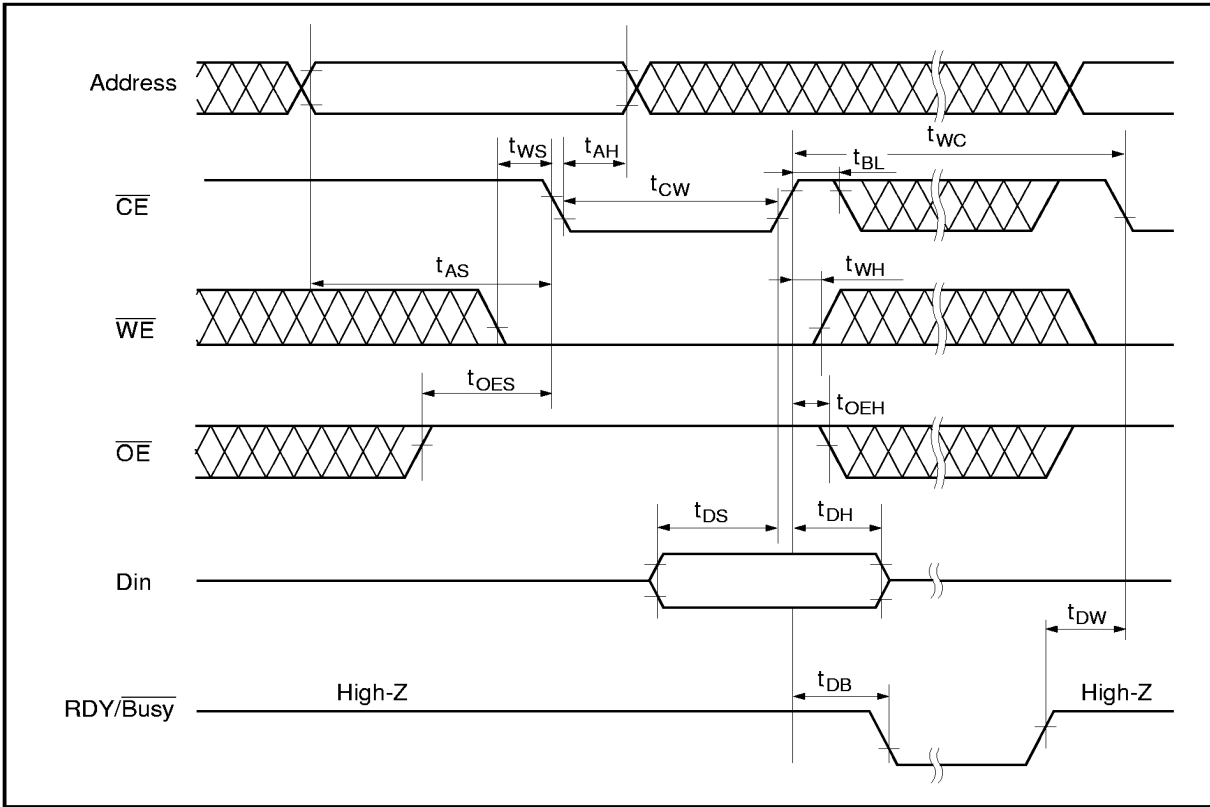

HN58C65 Series

Page Write Timing Waveform (1) (\overline{WE} Controlled)

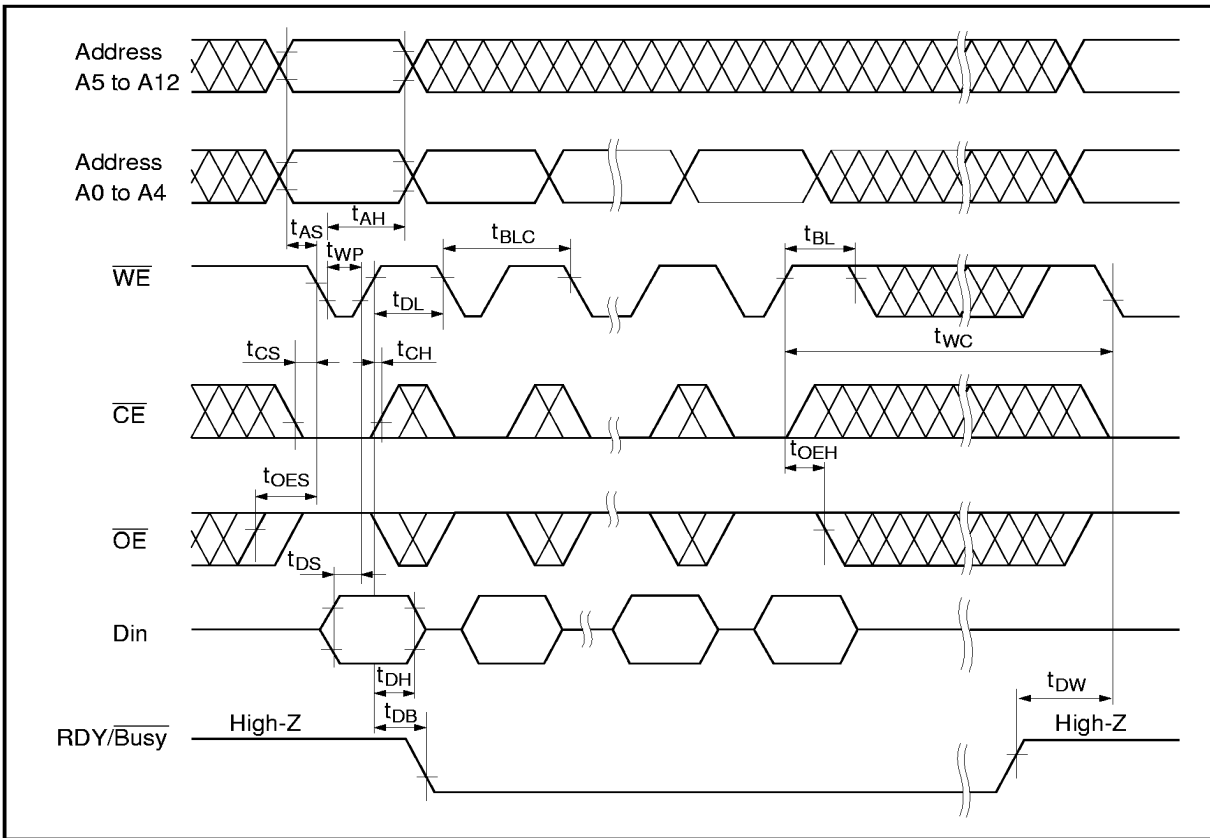

Page Write Timing Waveform (2) ($\overline{\text{CE}}$ Controlled)

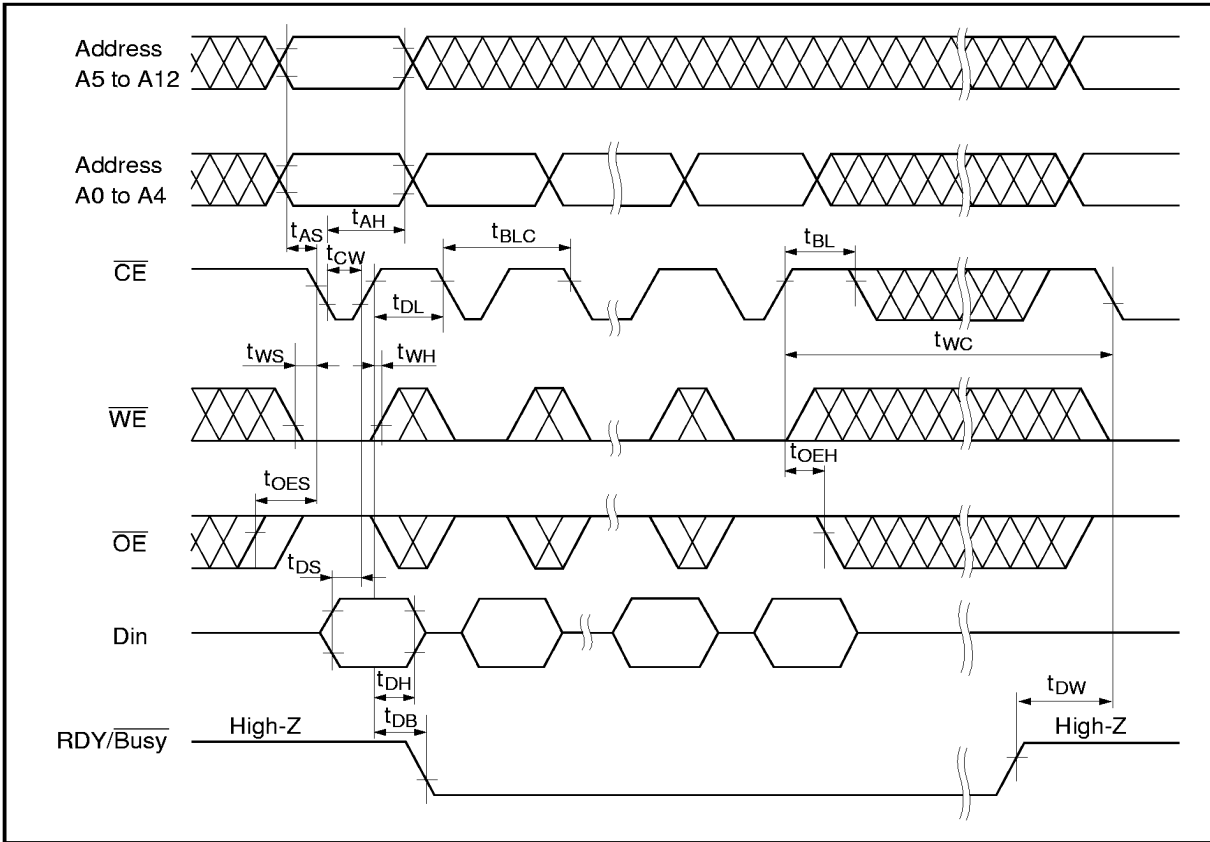

HN58C65 Series

Data Polling Timing Waveform

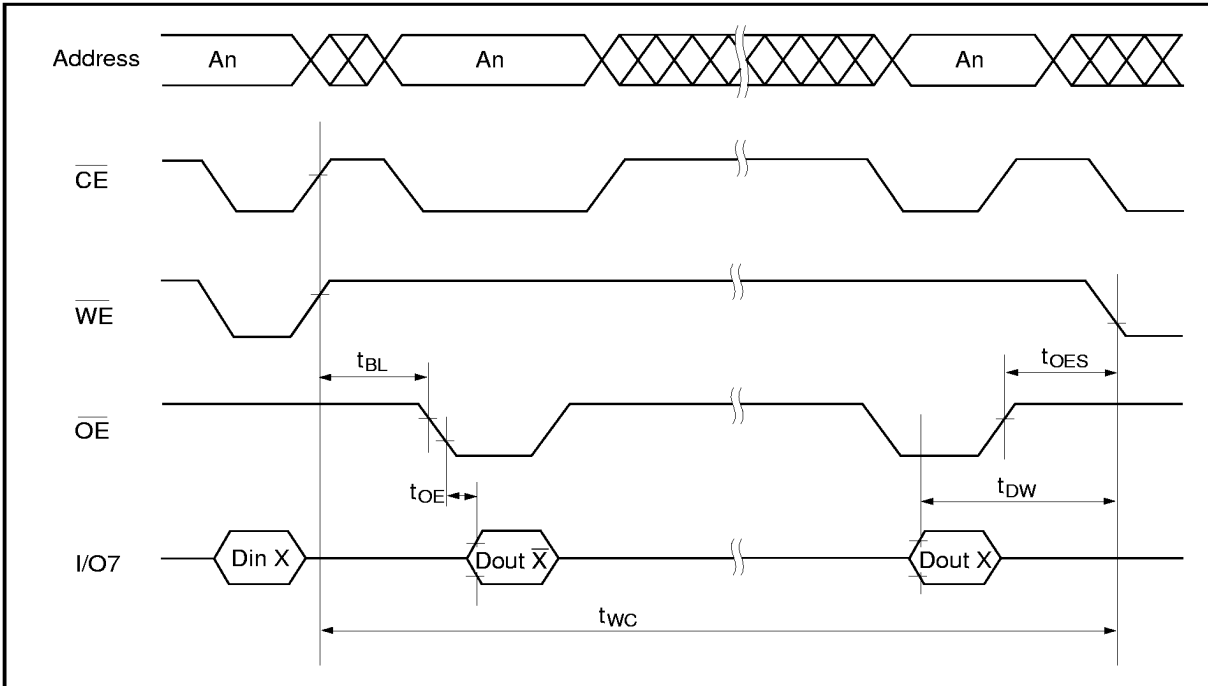

Functional Description

Automatic Page Write

Page-mode write feature allows 1 to 32 bytes of data to be written into the EEPROM in a single write cycle. Following the initial byte cycle, an additional 1 to 31 bytes can be written in the same manner. Each additional byte load cycle must be started within 30 μ s of the preceding rising edge of the \overline{WE} . When \overline{CE} or \overline{WE} is high for 100 μ s after data input, the EEPROM enters write mode automatically and the input data are written into the EEPROM.

Data Polling

Data polling allows the status of the EEPROM to be determined. If EEPROM is set to read mode during a write cycle, an inversion of the last byte of data to be loaded outputs from I/O7 to indicate that the EEPROM is performing a write operation.

RDY/Busy Signal

RDY/Busy signal also allows the status of the EEPROM to be determined. The RDY/Busy signal has high impedance, except in write cycle and is lowered to V_{OL} after the first write signal. At the end of a write cycle, the RDY/Busy signal changes state to high impedance.

HITACHI

12

$\overline{\text{WE}}$, $\overline{\text{CE}}$ Pin Operation

During a write cycle, addresses are latched by the falling edge of $\overline{\text{WE}}$ or $\overline{\text{CE}}$ and data is latched by the rising edge of $\overline{\text{WE}}$ or $\overline{\text{CE}}$.

Write/Erase Endurance and Data Retention Time

The endurance is 10^5 cycles in case of the page programming and 3×10^3 cycles in case of byte programming (1% cumulative failure rate). The data retention time is more than 10 years when a device is page-programmed less than 10^4 cycles.

Data Protection**1. Data Protection against Noise on Control Pins ($\overline{\text{CE}}$, $\overline{\text{OE}}$, $\overline{\text{WE}}$) during Operation**

During readout or standby, noise on the control pins may act as a trigger and turn the EEPROM to program mode by mistake. To prevent this phenomenon, this device has a noise cancelation function that cuts noise if its width is 20 ns or less in program mode. Be careful not to allow noise of a width of more than 20 ns on the control pins.

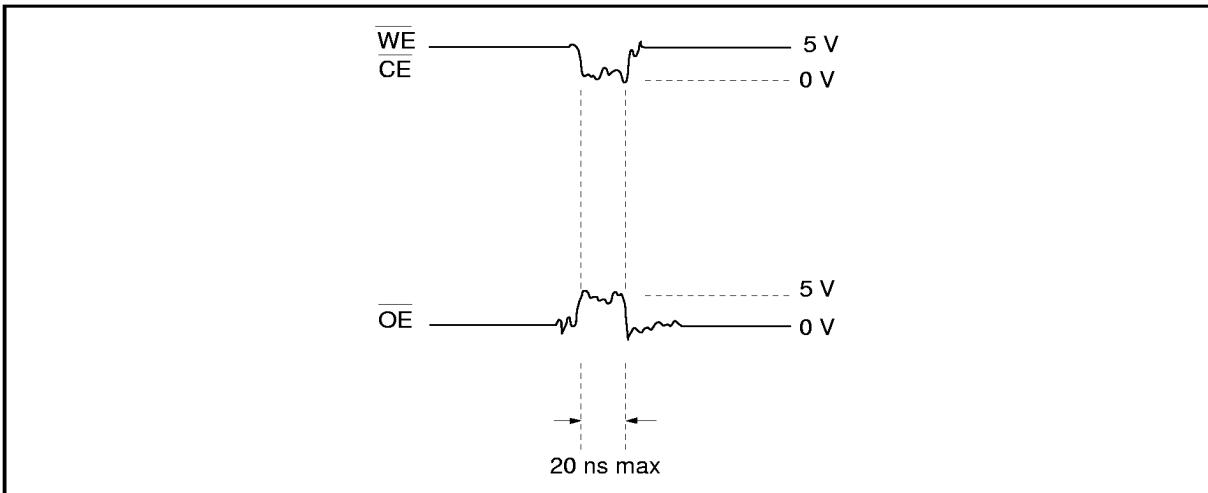

HN58C65 Series

2. Data Protection at V_{CC} On/Off

When V_{CC} is turned on or off, noise on the control pins generated by external circuits (CPU, etc.) may act as a trigger and turn the EEPROM to program mode by mistake. To prevent this unintentional programming, the EEPROM must be kept in an unprogrammable state while the CPU is in an unstable state.

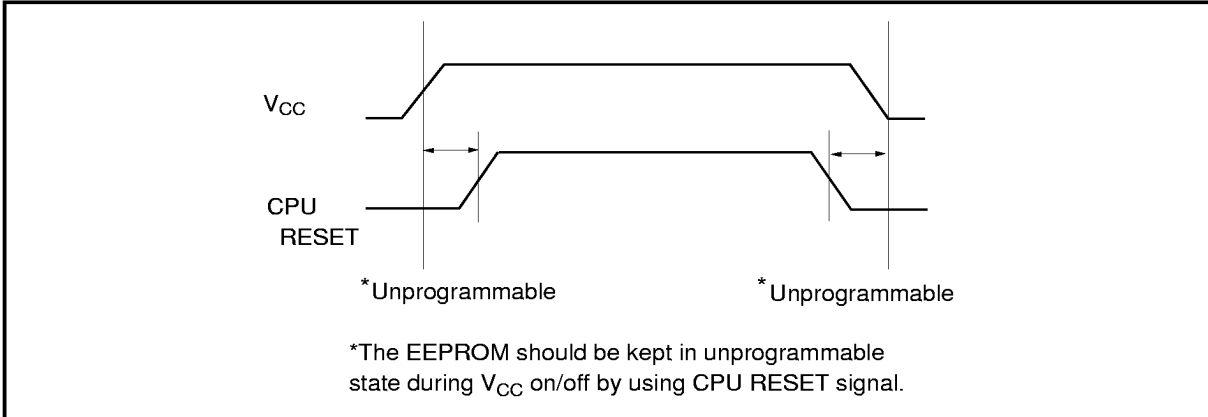

In addition, when V_{CC} is turned on or off, the input level of on control pins must be held as shown in the table below.

\overline{CE}	V_{CC}	X	X
\overline{OE}	X	V_{SS}	X
\overline{WE}	X	X	V_{CC}

X: Don't care.

V_{CC} : Pull-up to V_{CC} level

V_{SS} : Pull-down to V_{SS} level.

HN58C65 Series

Package Dimensions

HN58C65P series (DP-28)

Unit: mm

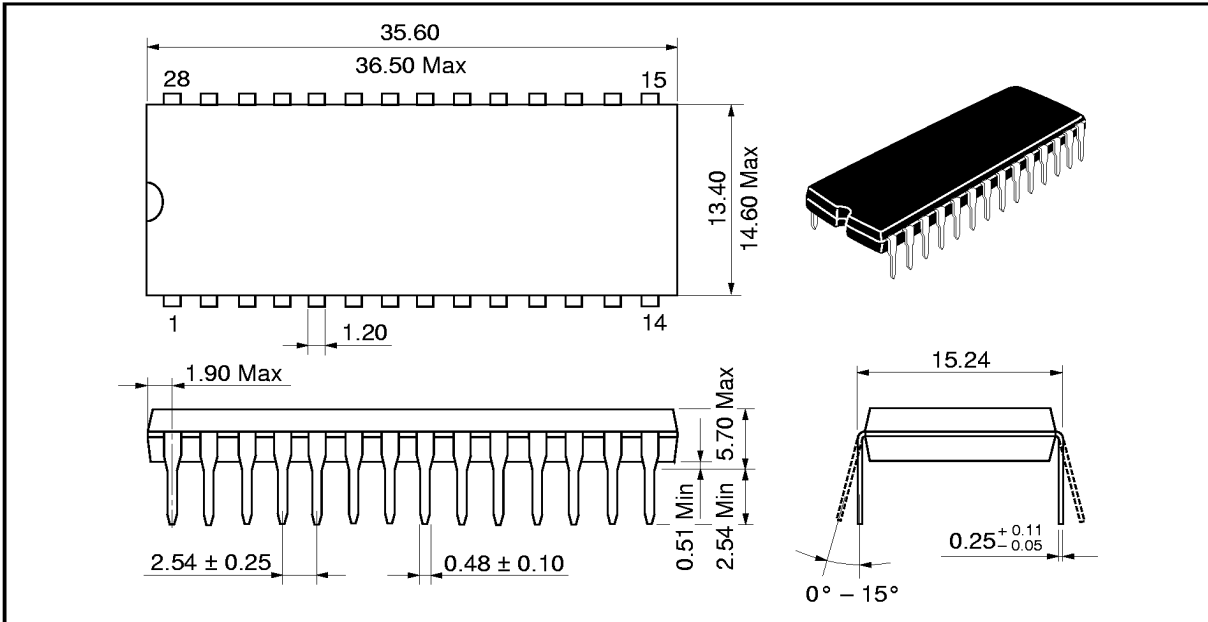

HN58C65FP Series (FP-28D)

Unit: mm

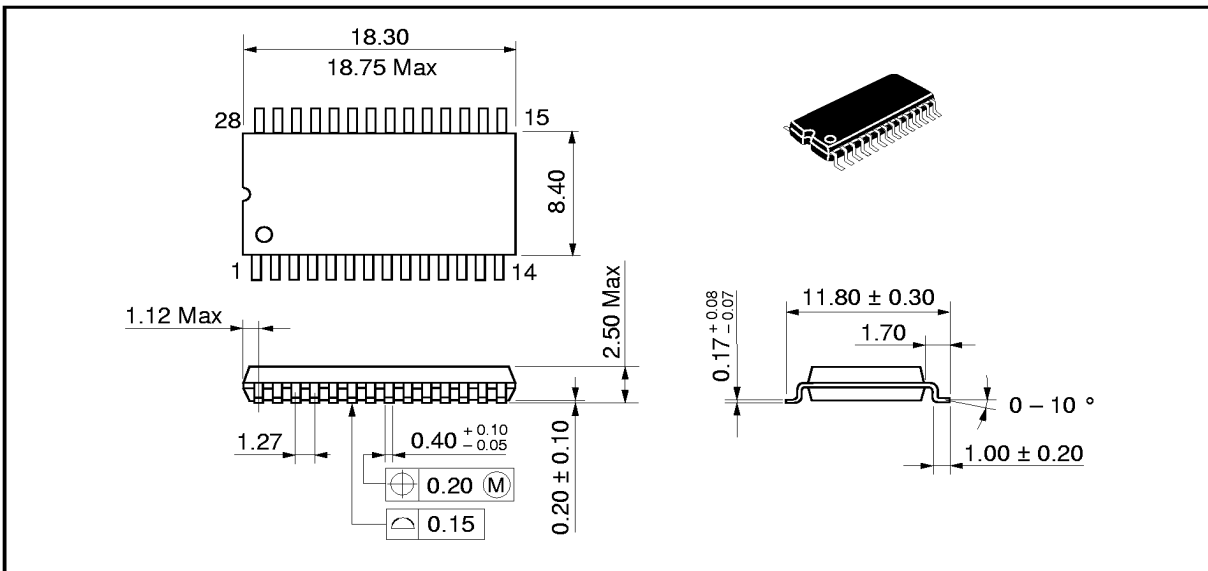

HITACHI

HN58C65 Series

HN58C65FP Series (FP-28DA)

Unit: mm

