



Integrated Device Technology, Inc.

# FAST CMOS 10-BIT BUFFERS

IDT54/74FCT827AT/BT/CT/DT  
IDT54/74FCT2827AT/BT/CT

## FEATURES:

- **Common features:**
  - Low input and output leakage  $\leq 1\mu\text{A}$  (max.)
  - CMOS power levels
  - True TTL input and output compatibility
    - $V_{OH} = 3.3\text{V}$  (typ.)
    - $V_{OL} = 0.3\text{V}$  (typ.)
  - Meets or exceeds JEDEC standard 18 specifications
  - Product available in Radiation Tolerant and Radiation Enhanced versions
  - Military product compliant to MIL-STD-883, Class B and DESC listed (dual marked)
  - Available in DIP, SOIC, SSOP, QSOP, CERPACK and LCC packages
- **Features for FCT827T:**
  - A, B, C and D speed grades
  - High drive outputs (-15mA IOH, 48mA IOL)
- **Features for FCT2827T:**
  - A, B and C speed grades
  - Resistor outputs (-15mA IOH, 12mA IOL Com.) (-12mA IOH, 12mA IOL Mil.)
  - Reduced system switching noise

## DESCRIPTION:

The FCT827T is built using an advanced dual metal CMOS technology.

The FCT827T/FCT2827T 10-bit bus drivers provide high-performance bus interface buffering for wide data/address paths or buses carrying parity. The 10-bit buffers have NAND-ed output enables for maximum control flexibility.

All of the FCT827T high-performance interface family are designed for high-capacitance load drive capability, while providing low-capacitance bus loading at both inputs and outputs. All inputs have clamp diodes to ground and all outputs are designed for low-capacitance bus loading in high-impedance state.

The FCT2827T has balanced output drive with current limiting resistors. This offers low ground bounce, minimal undershoot and controlled output fall times-reducing the need for external series terminating resistors. FCT2827T parts are plug-in replacements for FCT827T parts.

## FUNCTIONAL BLOCK DIAGRAM

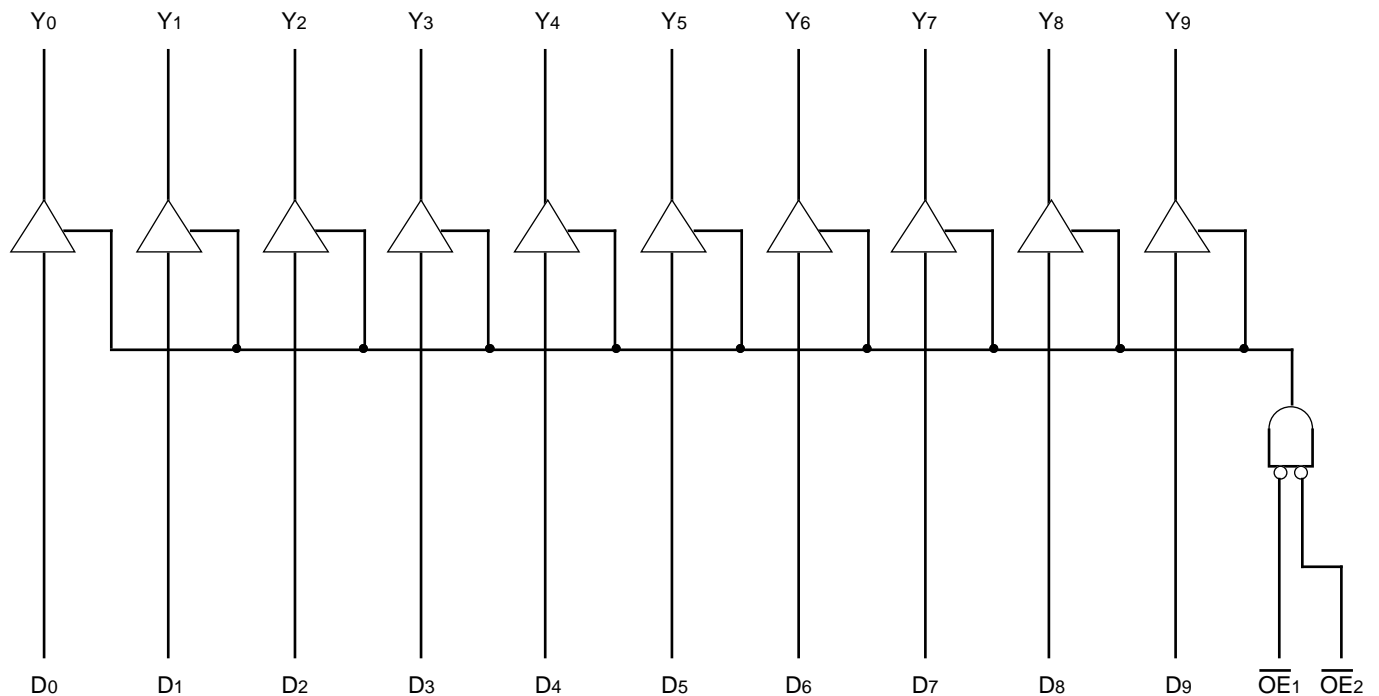

2573 drw 01

The IDT logo is a registered trademark of Integrated Device Technology, Inc.

MILITARY AND COMMERCIAL TEMPERATURE RANGES

AUGUST 1995

## PIN CONFIGURATIONS

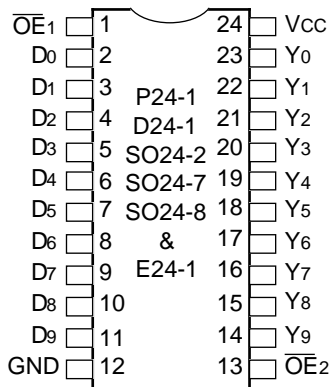

DIP/SOIC/SSOP/QSOP/CERPACK  
TOP VIEW

2573 drw 02

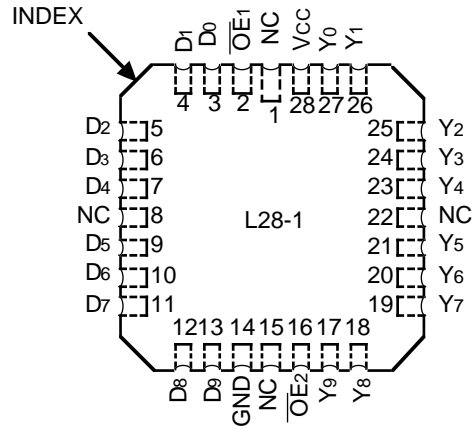

LCC  
TOP VIEW

2573 drw 03

## PIN DESCRIPTION

Names	I/O	Description
$\overline{OE}_i$	I	When both are LOW the outputs are enabled. When either one or both are HIGH the outputs are High Z.
$D_i$	I	10-bit data input.
$Y_i$	O	10-bit data output.

2573 tbl 01

## FUNCTION TABLE<sup>(1)</sup>

Inputs			Output	Function
$\overline{OE}_1$	$\overline{OE}_2$	$D_i$	$Y_i$	
L	L	L	L	Transparent
L	L	H	H	
H	X	X	Z	Three-State
X	H	X	Z	

NOTE:

1. H = HIGH, L = LOW, X = Don't Care, Z = High Impedance

2573 tbl 02

## ABSOLUTE MAXIMUM RATINGS<sup>(1)</sup>

Symbol	Rating	Commercial	Military	Unit
$V_{TERM}^{(2)}$	Terminal Voltage with Respect to GND	-0.5 to +7.0	-0.5 to +7.0	V
$V_{TERM}^{(3)}$	Terminal Voltage with Respect to GND	-0.5 to $V_{CC} + 0.5$	-0.5 to $V_{CC} + 0.5$	V
$T_A$	Operating Temperature	0 to +70	-55 to +125	°C
$T_{BIAS}$	Temperature Under Bias	-55 to +125	-65 to +135	°C
$T_{STG}$	Storage Temperature	-55 to +125	-65 to +150	°C
PT	Power Dissipation	0.5	0.5	W
$I_{OUT}$	DC Output Current	-60 to +120	-60 to +120	mA

2573 lmk 03

### NOTES:

- Stresses greater than those listed under ABSOLUTE MAXIMUM RATINGS may cause permanent damage to the device. This is a stress rating only and functional operation of the device at these or any other conditions above those indicated in the operational sections of this specification is not implied. Exposure to absolute maximum rating conditions for extended periods may affect reliability. No terminal voltage may exceed  $V_{CC}$  by +0.5V unless otherwise noted.
- Input and  $V_{CC}$  terminals only.
- Outputs and I/O terminals only.

## CAPACITANCE ( $T_A = +25^\circ\text{C}$ , $f = 1.0\text{MHz}$ )

Symbol	Parameter <sup>(1)</sup>	Conditions	Typ.	Max.	Unit
$C_{IN}$	Input Capacitance	$V_{IN} = 0V$	6	10	pF
$C_{OUT}$	Output Capacitance	$V_{OUT} = 0V$	8	12	pF

NOTE:

1. This parameter is measured at characterization but not tested.

2573 lmk 04

## DC ELECTRICAL CHARACTERISTICS OVER OPERATING RANGE

Following Conditions Apply Unless Otherwise Specified:

Commercial:  $T_A = 0^\circ\text{C}$  to  $+70^\circ\text{C}$ ,  $V_{CC} = 5.0\text{V} \pm 5\%$ ; Military:  $T_A = -55^\circ\text{C}$  to  $+125^\circ\text{C}$ ,  $V_{CC} = 5.0\text{V} \pm 10\%$

Symbol	Parameter	Test Conditions <sup>(1)</sup>		Min.	Typ. <sup>(2)</sup>	Max.	Unit
$V_{IH}$	Input HIGH Level	Guaranteed Logic HIGH Level		2.0	—	—	V
$V_{IL}$	Input LOW Level	Guaranteed Logic LOW Level		—	—	0.8	V
$I_{IH}$	Input HIGH Current <sup>(4)</sup>	$V_{CC} = \text{Max.}$	$V_I = 2.7\text{V}$	—	—	$\pm 1$	$\mu\text{A}$
$I_{IL}$	Input LOW Current <sup>(4)</sup>		$V_I = 0.5\text{V}$	—	—	$\pm 1$	
$I_{OZH}$	High Impedance Output Current (3-State Output pins) <sup>(4)</sup>	$V_{CC} = \text{Max.}$	$V_O = 2.7\text{V}$	—	—	$\pm 1$	$\mu\text{A}$
$I_{OZL}$			$V_O = 0.5\text{V}$	—	—	$\pm 1$	
$I_I$	Input HIGH Current <sup>(4)</sup>	$V_{CC} = \text{Max.}, V_I = V_{CC} (\text{Max.})$		—	—	$\pm 1$	$\mu\text{A}$
$V_{IK}$	Clamp Diode Voltage	$V_{CC} = \text{Min.}, I_{IN} = -18\text{mA}$		—	-0.7	-1.2	V
$V_H$	Input Hysteresis	—		—	200	—	mV
$I_{CC}$	Quiescent Power Supply Current	$V_{CC} = \text{Max.}, V_{IN} = \text{GND or } V_{CC}$		—	0.01	1	mA

2573 Ink 05

## OUTPUT DRIVE CHARACTERISTICS FOR FCT827T

Symbol	Parameter	Test Conditions <sup>(1)</sup>		Min.	Typ. <sup>(2)</sup>	Max.	Unit
$V_{OH}$	Output HIGH Voltage	$V_{CC} = \text{Min.}$ $V_{IN} = V_{IH} \text{ or } V_{IL}$	$I_{OH} = -6\text{mA MIL.}$ $I_{OH} = -8\text{mA COM'L.}$	2.4	3.3	—	V
			$I_{OH} = -12\text{mA MIL.}$ $I_{OH} = -15\text{mA COM'L.}$	2.0	3.0	—	V
			$I_{OL} = 32\text{mA MIL.}$ $I_{OL} = 48\text{mA COM'L.}$	—	0.3	0.5	V
$I_{OS}$	Short Circuit Current	$V_{CC} = \text{Max.}, V_O = \text{GND}^{(3)}$		-60	-120	-225	mA

2573 Ink 06

## OUTPUT DRIVE CHARACTERISTICS FOR FCT2827T

Symbol	Parameter	Test Conditions <sup>(1)</sup>		Min.	Typ. <sup>(2)</sup>	Max.	Unit
$I_{ODL}$	Output LOW Current	$V_{CC} = 5\text{V}, V_{IN} = V_{IH} \text{ or } V_{IL}, V_{OUT} = 1.5\text{V}^{(3)}$		16	48	—	mA
$I_{ODH}$	Output HIGH Current	$V_{CC} = 5\text{V}, V_{IN} = V_{IH} \text{ or } V_{IL}, V_{OUT} = 1.5\text{V}^{(3)}$		-16	-48	—	mA
$V_{OH}$	Output HIGH Voltage	$V_{CC} = \text{Min.}$ $V_{IN} = V_{IH} \text{ or } V_{IL}$	$I_{OH} = -12\text{mA MIL.}$ $I_{OH} = -15\text{mA COM'L.}$	2.4	3.3	—	V
$V_{OL}$	Output LOW Voltage	$V_{CC} = \text{Min.}$ $V_{IN} = V_{IH} \text{ or } V_{IL}$	$I_{OL} = 12\text{mA}$	—	0.3	0.50	V

2573 Ink 07

### NOTES:

- For conditions shown as Max. or Min., use appropriate value specified under Electrical Characteristics for the applicable device type.
- Typical values are at  $V_{CC} = 5.0\text{V}$ ,  $+25^\circ\text{C}$  ambient.
- Not more than one output should be shorted at one time. Duration of the short circuit test should not exceed one second.
- The test limit for this parameter is  $\pm 5\mu\text{A}$  at  $T_A = -55^\circ\text{C}$ .

## POWER SUPPLY CHARACTERISTICS

Symbol	Parameter	Test Conditions <sup>(1)</sup>			Min.	Typ. <sup>(2)</sup>	Max.	Unit
$\Delta I_{CC}$	Quiescent Power Supply Current TTL Inputs HIGH	$V_{CC} = \text{Max.}$ $V_{IN} = 3.4V^{(3)}$			—	0.5	2.0	mA
$I_{CCD}$	Dynamic Power Supply Current <sup>(4)</sup>	$V_{CC} = \text{Max.}$ Outputs Open $\overline{OE}_1 = \overline{OE}_2 = \text{GND}$ One Input Toggling 50% Duty Cycle	$V_{IN} = V_{CC}$ $V_{IN} = \text{GND}$	FCT827T	—	0.15	0.25	mA/ MHz
				FCT2827T	—	0.06	0.12	
$I_C$	Total Power Supply Current <sup>(6)</sup>	$V_{CC} = \text{Max.}$ Outputs Open $f_i = 10\text{MHz}$ 50% Duty Cycle $\overline{OE}_1 = \overline{OE}_2 = \text{GND}$ One Bit Toggling	$V_{IN} = V_{CC}$ $V_{IN} = \text{GND}$	FCT827T	—	1.5	3.5	mA
				FCT2827T	—	0.6	2.2	
			$V_{IN} = 3.4V$ $V_{IN} = \text{GND}$	FCT827T	—	1.8	4.5	
				FCT2827T	—	0.9	3.2	
			$V_{IN} = V_{CC}$ $V_{IN} = \text{GND}$	FCT827T	—	3.0	6.0 <sup>(5)</sup>	
				FCT2827T	—	1.2	3.4 <sup>(5)</sup>	
		$V_{IN} = 3.4V$ $V_{IN} = \text{GND}$	FCT827T	—	5.0	14.0 <sup>(5)</sup>		
			FCT2827T	—	3.2	11.4 <sup>(5)</sup>		

**NOTES:**

- For conditions shown as Max. or Min., use appropriate value specified under Electrical Characteristics for the applicable device type.
- Typical values are at  $V_{CC} = 5.0V$ ,  $+25^\circ\text{C}$  ambient.
- Per TTL driven input ( $V_{IN} = 3.4V$ ). All other inputs at  $V_{CC}$  or  $\text{GND}$ .
- This parameter is not directly testable, but is derived for use in Total Power Supply Calculations.
- Values for these conditions are examples of the  $I_{CC}$  formula. These limits are guaranteed but not tested.
- $I_C = I_{QUIESCENT} + I_{INPUTS} + I_{DYNAMIC}$   
 $I_C = I_{CC} + \Delta I_{CC} D_{HNT} + I_{CCD} (f_{CP}/2 + f_i N_i)$   
 $I_{CC}$  = Quiescent Current  
 $\Delta I_{CC}$  = Power Supply Current for a TTL High Input ( $V_{IN} = 3.4V$ )  
 $D_H$  = Duty Cycle for TTL Inputs High  
 $N_T$  = Number of TTL Inputs at  $D_H$   
 $I_{CCD}$  = Dynamic Current Caused by an Input Transition Pair (HLH or LHL)  
 $f_{CP}$  = Clock Frequency for Register Devices (Zero for Non-Register Devices)  
 $f_i$  = Input Frequency  
 $N_i$  = Number of Inputs at  $f_i$   
 All currents are in milliamps and all frequencies are in megahertz.

2573 tbl 08

**SWITCHING CHARACTERISTICS OVER OPERATING RANGE**

Symbol	Parameter	Condition <sup>(1)</sup>	FCT827AT/FCT2827AT				FCT827BT/FCT2827BT				Unit
			Com'l.		Mil.		Com'l.		Mil.		
			Min. <sup>(2)</sup>	Max.	Min. <sup>(2)</sup>	Max.	Min. <sup>(2)</sup>	Max.	Min. <sup>(2)</sup>	Max.	
tPLH tPHL	Propagation Delay Di to Yi	CL = 50pF RL = 500Ω	1.5	8.0	1.5	9.0	1.5	5.0	1.5	6.5	ns
		CL = 300pF <sup>(3)</sup> RL = 500Ω	1.5	15.0	1.5	17.0	1.5	13.0	1.5	14.0	
tPZH tPZL	Output Enable Time OEi to Yi	CL = 50pF RL = 500Ω	1.5	12.0	1.5	13.0	1.5	8.0	1.5	9.0	ns
		CL = 300pF <sup>(3)</sup> RL = 500Ω	1.5	23.0	1.5	25.0	1.5	15.0	1.5	16.0	
tPHZ tPLZ	Output Disable Time OEi to Yi	CL = 5pF <sup>(3)</sup> RL = 500Ω	1.5	9.0	1.5	9.0	1.5	6.0	1.5	7.0	ns
		CL = 50pF RL = 500Ω	1.5	10.0	1.5	10.0	1.5	7.0	1.5	8.0	

2573 tbl 09

Symbol	Parameter	Condition <sup>(1)</sup>	FCT827CT/FCT2827CT				FCT827DT				Unit
			Com'l.		Mil.		Com'l.		Mil.		
			Min. <sup>(2)</sup>	Max.	Min. <sup>(2)</sup>	Max.	Min. <sup>(2)</sup>	Max.	Min. <sup>(2)</sup>	Max.	
tPLH tPHL	Propagation Delay Di to Yi	CL = 50pF RL = 500Ω	1.5	4.4	1.5	5.0	1.5	3.8	—	—	ns
		CL = 300pF <sup>(3)</sup> RL = 500Ω	1.5	10.0	1.5	11.0	1.5	7.5	—	—	
tPZH tPZL	Output Enable Time OEi to Yi	CL = 50pF RL = 500Ω	1.5	7.0	1.5	8.0	1.5	5.0	—	—	ns
		CL = 300pF <sup>(3)</sup> RL = 500Ω	1.5	14.0	1.5	15.0	1.5	9.0	—	—	
tPHZ tPLZ	Output Disable Time OEi to Yi	CL = 5pF <sup>(3)</sup> RL = 500Ω	1.5	5.7	1.5	6.7	1.5	4.3	—	—	ns
		CL = 50pF RL = 500Ω	1.5	6.0	1.5	7.0	1.5	4.3	—	—	

2573 tbl 10

**NOTES:**

1. See test circuit and waveforms.
2. Minimum limits are guaranteed but not tested on Propagation Delays.
3. These conditions are guaranteed but not tested.

## TEST CIRCUITS AND WAVEFORMS

### TEST CIRCUITS FOR ALL OUTPUTS

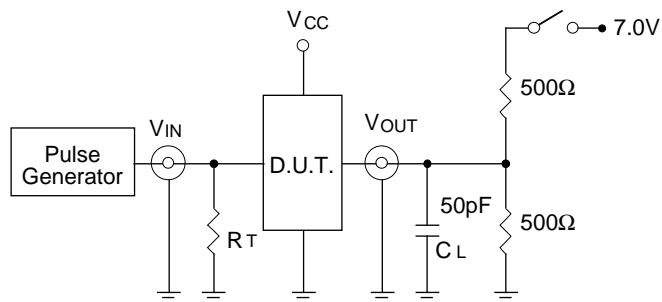

2573 drw 04

### SWITCH POSITION

Test	Switch
Open Drain Disable Low Enable Low	Closed
All Other Tests	Open

#### DEFINITIONS:

$C_L$  = Load capacitance: includes jig and probe capacitance.  
 $R_T$  = Termination resistance: should be equal to  $Z_{out}$  of the Pulse Generator.

2573 ink 11

### SET-UP, HOLD AND RELEASE TIMES

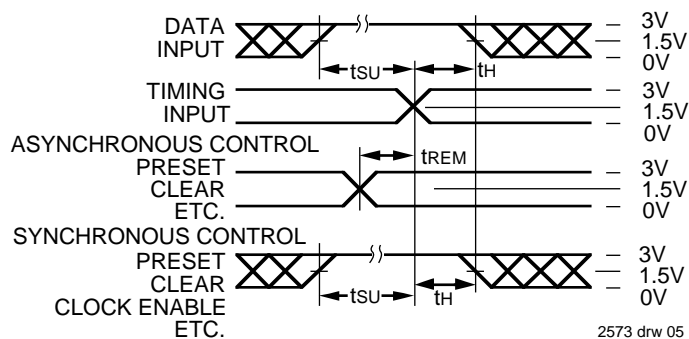

2573 drw 05

### PULSE WIDTH

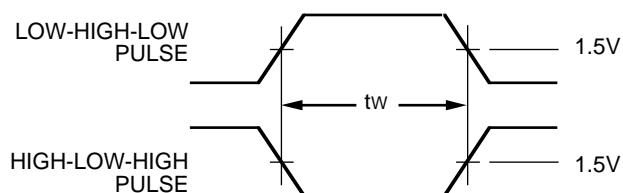

2573 drw 06

### PROPAGATION DELAY

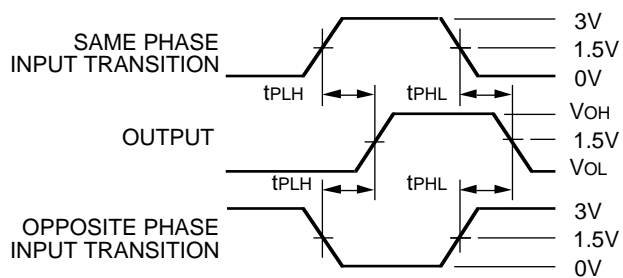

2573 drw 07

### ENABLE AND DISABLE TIMES

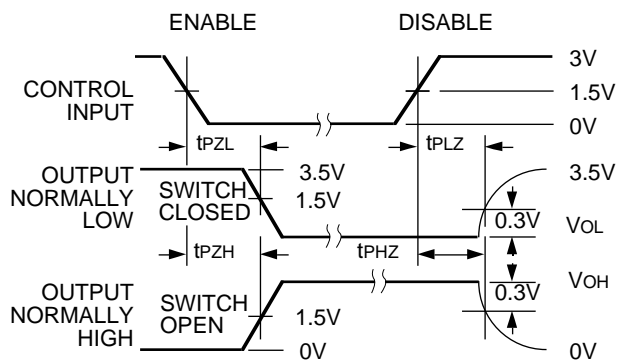

2573 drw 08

#### NOTES:

- Diagram shown for input Control Enable-LOW and input Control Disable-HIGH
- Pulse Generator for All Pulses: Rate  $\leq 1.0\text{MHz}$ ;  $t_f \leq 2.5\text{ns}$ ;  $t_r \leq 2.5\text{ns}$

**ORDERING INFORMATION**

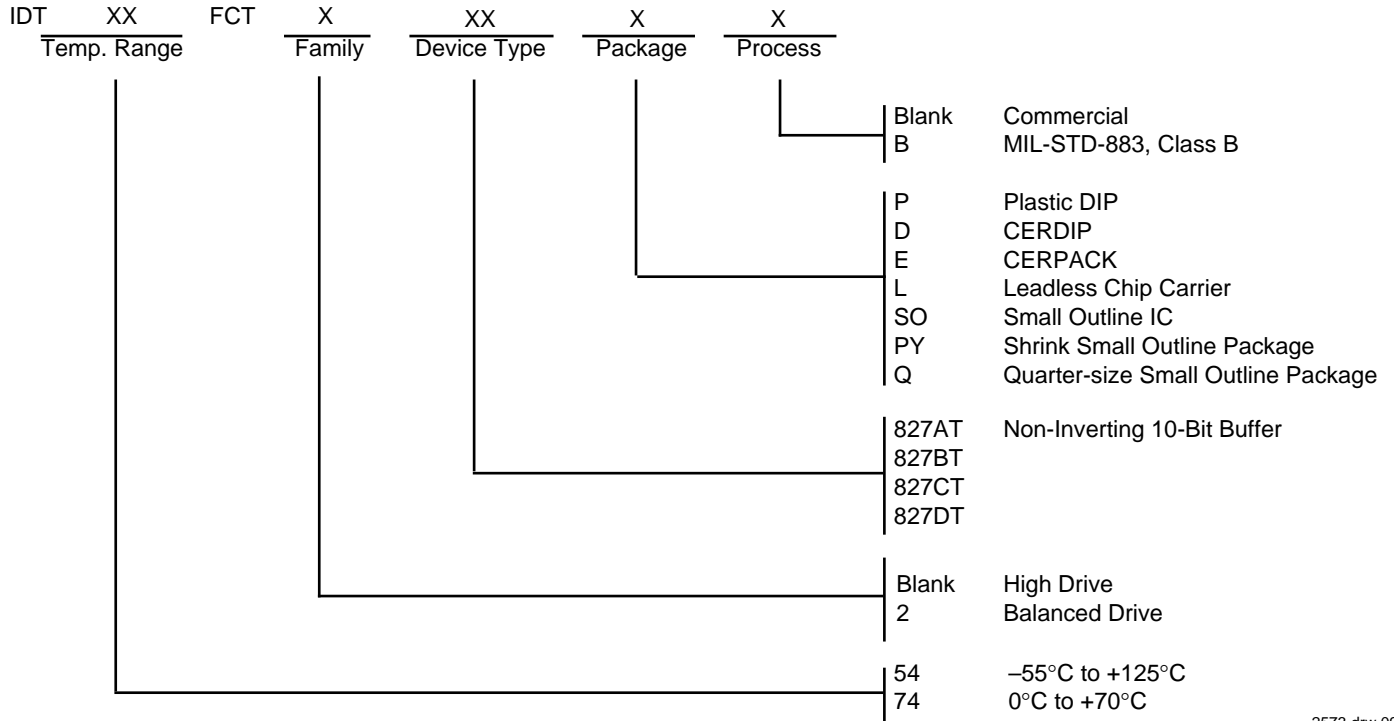

2573 drw 09

This datasheet has been downloaded from:

[www.DatasheetCatalog.com](http://www.DatasheetCatalog.com)

Datasheets for electronic components.



LittleDiode supplies new, hard to find or obsolete electronic components and semiconductors all over the world.

With over two million different components listed you are sure to find the part you need.

Feel free to visit us today at our online store:

**[LittleDiode.com](http://LittleDiode.com)**

Looking forward to providing you with the best possible service.