

TDA7300

PIN CONNECTION (Top view)

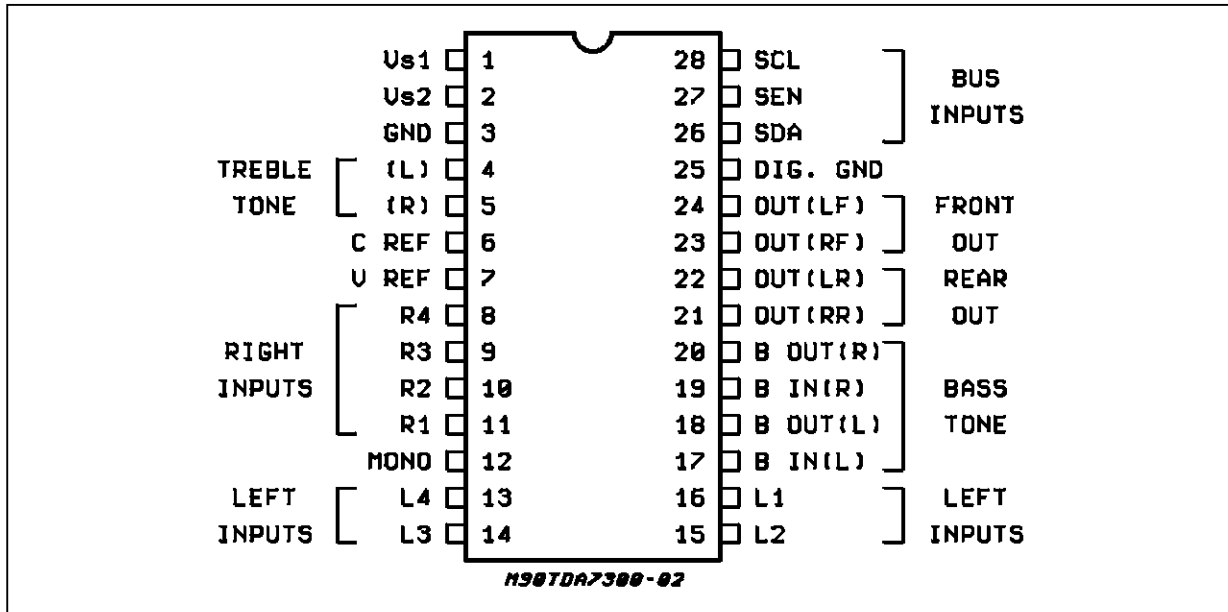

ABSOLUTE MAXIMUM RATINGS

Symbol	Parameter	Value	Unit
V_S	Supply Voltage (V_{S1})	18	V
T_{amb}	Operating Ambient Temperature Range	-40 to +85	°C
T_{stg}	Storage Temperature	-40 to 150	°C

THERMAL DATA

Symbol	Description	SO28	DIP28	Unit
$R_{th\ j-pins}$	Thermal Resistance Junction-pins Max	85	65	°C/W

ELECTRICAL CHARACTERISTICS ($T_{amb} = 25^\circ\text{C}$, $V_{S1} = 12\text{V}$ or $V_{S2} = 8.5\text{V}$, $R_L = 10\text{k}\Omega$ and $R_g = 600\Omega$, $f = 1\text{KHz}$ unless otherwise specified)

Symbol	Parameter	Test Condition	Min.	Typ.	Max.	Unit
--------	-----------	----------------	------	------	------	------

SUPPLY (1)

V_{S1}	Supply Voltage V_{S1}		10	12	16	V
V_{S2}	Supply Voltage V_{S2}		6	8.5	10	V
I_{S2}	Supply Current		15	30	40	mA
V_{ref}	Reference Voltage (pin 7)		3.5	4.3	5	V
SVR	Ripple Rejection at V_{S1}	$f = 300\text{Hz}$ to 10KHz	80	97		dB
SVR	Ripple Rejection at V_{S2}	$f = 300\text{Hz}$ to 10KHz	50	58		dB

INPUT SELECTORS

R_i	Input Resistance		30	45		$\text{K}\Omega$
$V_{IN\ max}$	Max. Input Signal	$GV = 0\text{dB}$ $d = 0.3\%$	1.5	2.2		V_{rms}
IN_s	Input Separation	$f = 1\text{KHz}$ (2)	90	100		dB
		$f = 10\text{KHz}$ (2)	70	80		dB
$V_i\ (DC)$	Input DC Voltage		3.5	4.3	5	V

ELECTRICAL CHARACTERISTICS (continued)

Symbol	Parameter	Test Condition	Min.	Typ.	Max.	Unit
--------	-----------	----------------	------	------	------	------

VOLUME CONTROLS

	Control Range			78		dB
G_{max}	Max Gain		8	10	12	dB
	Max Attenuation		64	68		dB
	Step Resolution	$G_V = -50$ to 10dB		2	3	dB
	Attenuator Set Error				2	dB
	Tracking Error				2	dB

SPEAKER ATTENUATORS

	Control Range		35	38	41	dB
	Step Resolution			2	3	dB
	Attenuator Set Error				2	dB
	Tracking Error				2	dB

BASS AND TREBLE CONTROL (3)

	Control Range			± 15		dB
	Step Resolution			2.5	3.5	dB

AUDIO OUTPUT

V_O	Max. Output Voltage	$d = 0.3\%$	1.5	2.2		V _{rms}
R_L	Output Load Resistance		2			K Ω
C_L	Output Load Capacitance				1	nF
R_O	Output Resistance			70	150	Ω
$V_O(DC)$	DC Voltage Level		3	3.8	4.5	V

GENERAL

e_{NO}	Output Noise	BW = 22Hz to 22KHz, $G_V = 0$ dB		6	15	μ V
		Curve A $G_V = 0$ dB		4		
S/N	Signal to Noise Ratio	All gain = 0dB $V_O = 1$ V _{rms} BW = 22Hz to 22KHz		105		dB
d	Distortion	$f = 1$ KHz; $V_O = 1$ V; $G_V = 0$		0.01	0.1	%
	Frequency Response (-1dB)	$G_V = 0$	High Low	20	20	KHz Hz
S_C	Channel Separation left/right	$f = 1$ KHz		90	100	dB
		$f = 10$ KHz		70	80	dB

BUS INPUTS

V_{IL}	Input LOW Voltage				0.8	V
V_{IH}	Input HIGH Voltage		2.4			V
V_O	Output Voltage SDA Acknowledge	$I = 1.6$ mA			0.4	V
	Digital Input Current		-5		+5	μ A

Notes:

- (1) The circuit can be supplied either at V_{S1} or without the use of the internal voltage regulator at V_{S2} . The circuit also operates at a supply voltage V_{S1} lower than 10V. In this case the ripple rejection of V_{S2} is valid, because the voltage regulator saturates to a saturation voltage of about 0.8V.
- (2) The selected input is grounded thru the 2.2 μ F capacitor.
- (3) Bass and Treble response see attached diagram. The center frequency and quality of the resonance behaviour can be chosen by the external circuitry. A standard first order bass response can be realized by a standard feedback network.

TDA7300

Figure 1: Application Circuit

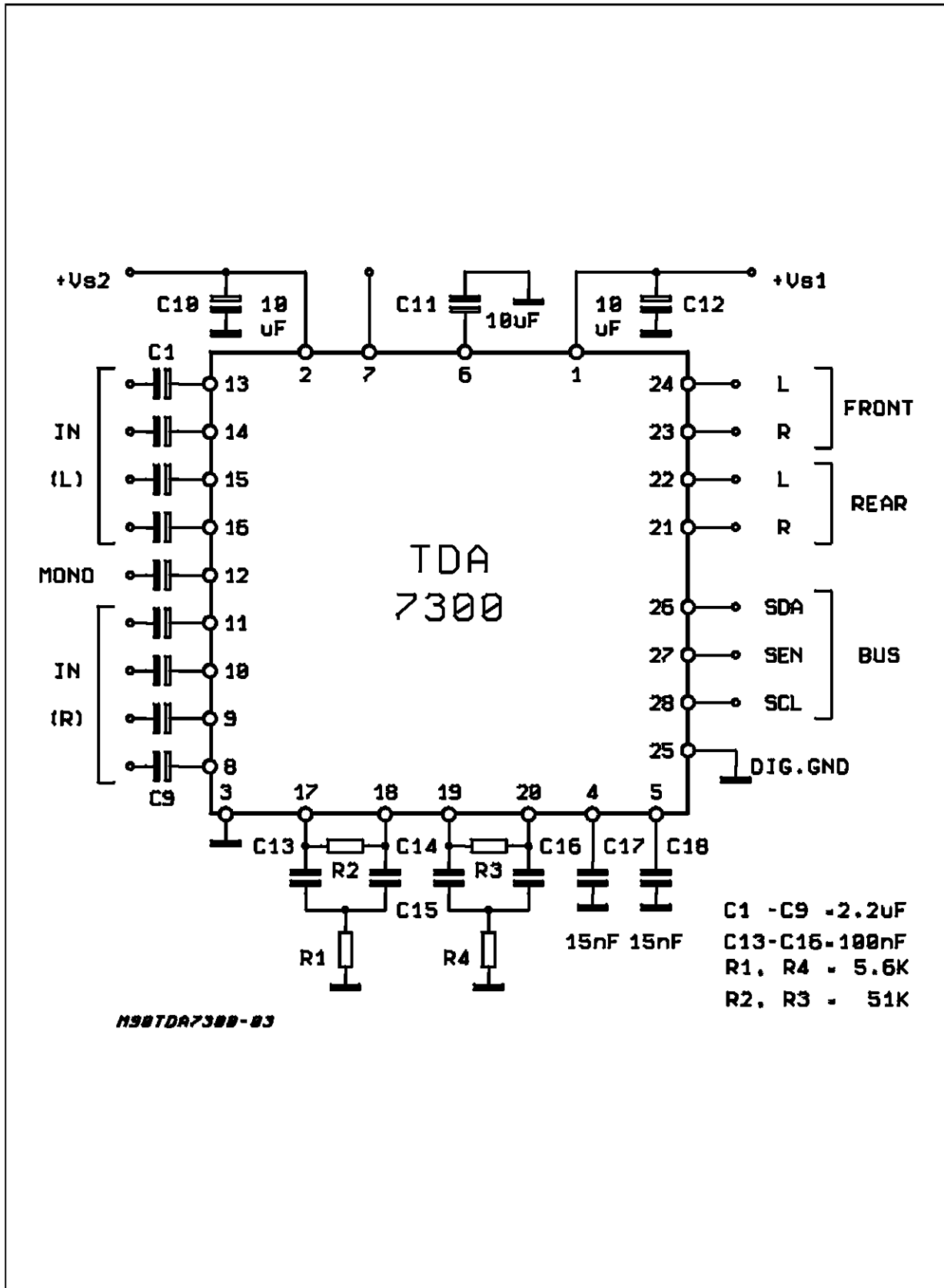

Figure 2: P.C. Board and Components Layout of the Fig.1 (1:1 scale)

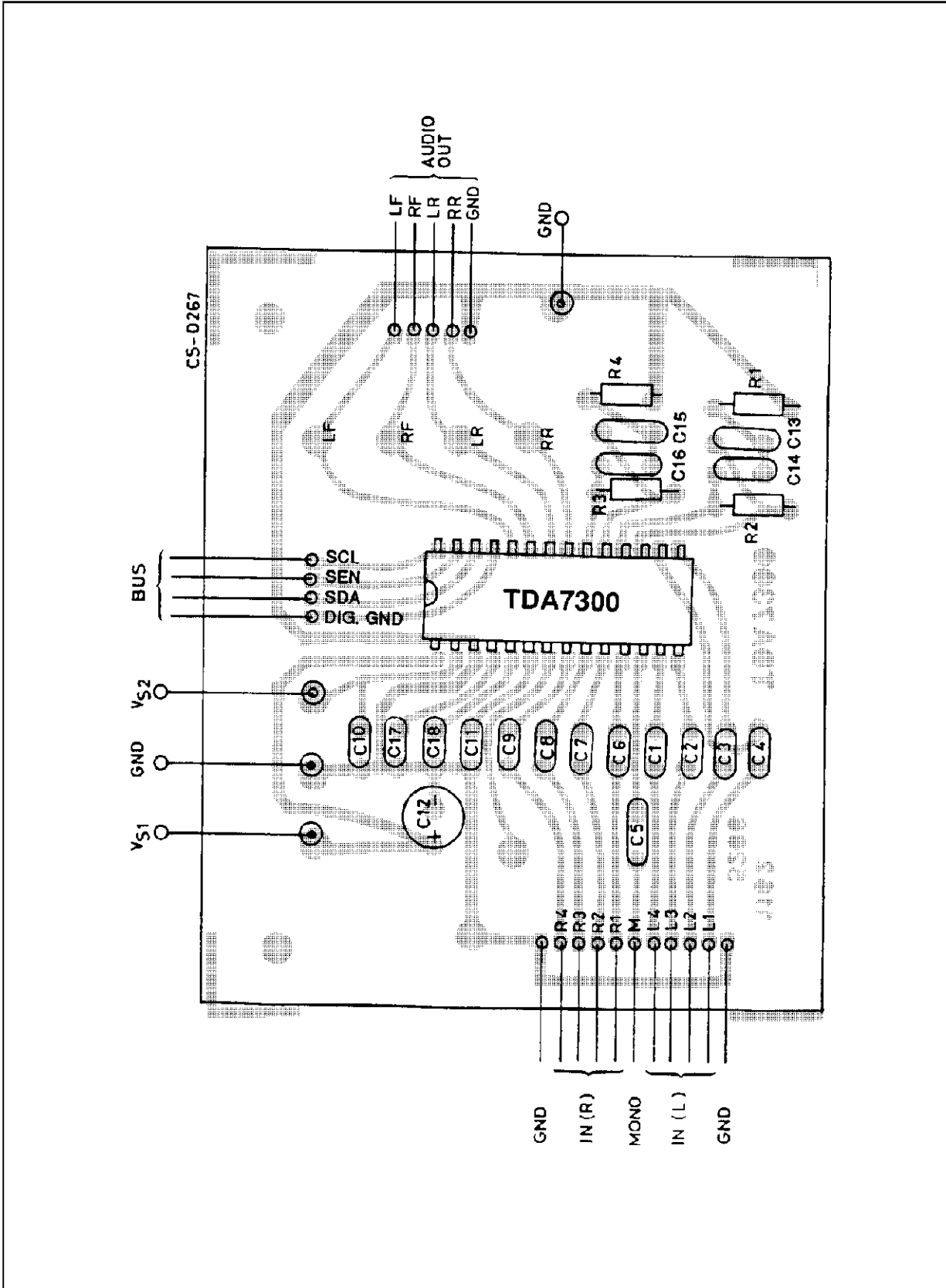

Figure 3: Total Output Noise vs. Volume Setting

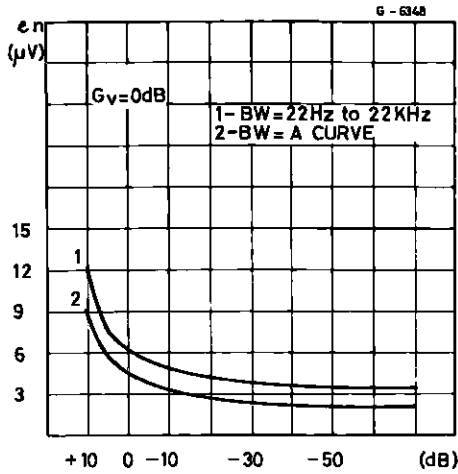

Figure 4: Signal to Noise Ratio vs. Volume Setting

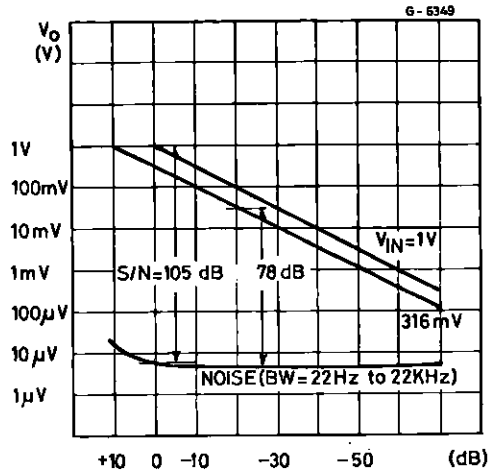

Figure 5: Distortion + Noise vs. Frequency

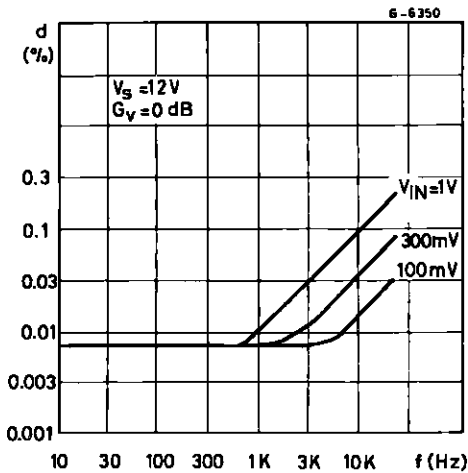

Figure 6: Distortion vs. Output Voltage

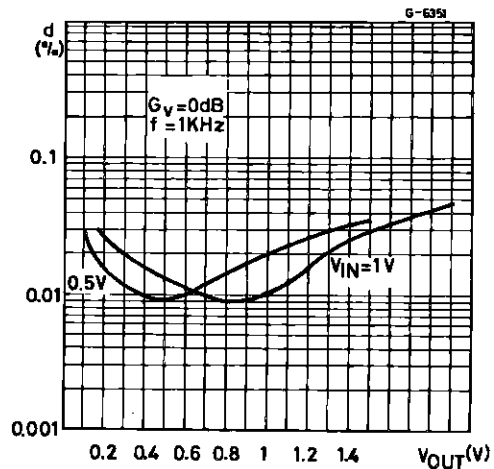

Figure 7: Distortion vs. Load Resistance

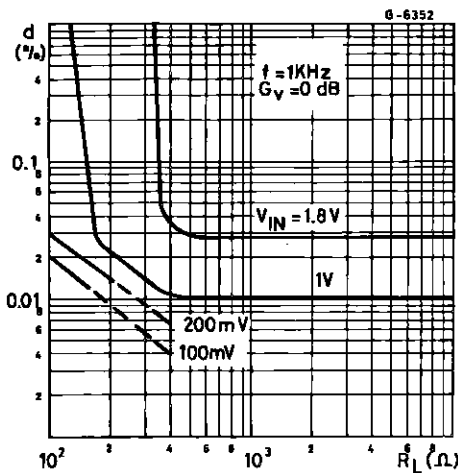

Figure 8: Channel Separation (L1 - R1) vs. Frequency

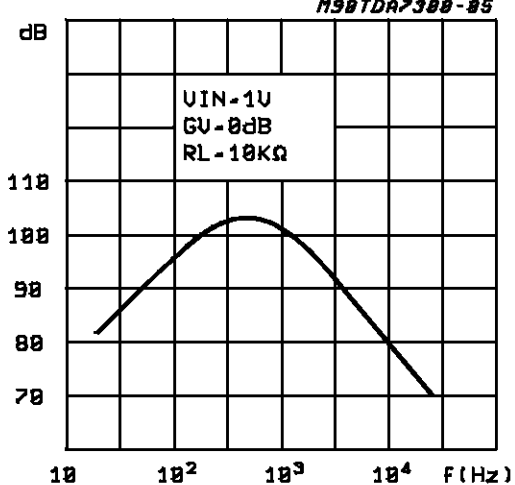

Figure 9: Input Separation (L1 - L2) vs. (V_{S1}) Frequency

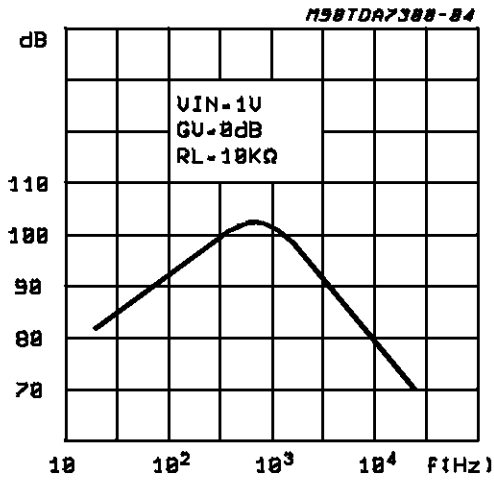

Figure 10: Supply Voltage Rejection (V_{S1}) vs. Frequency

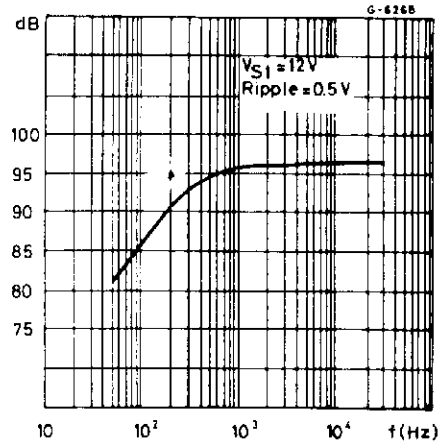

Figure 11: Supply Voltage Rejection (V_{S2}) vs. Frequency

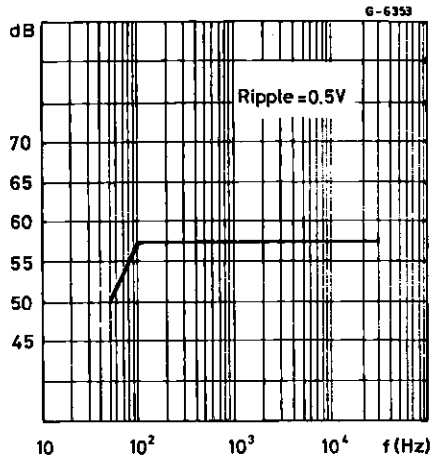

Figure 12: Supply Voltage Rejection vs. V_{S1}

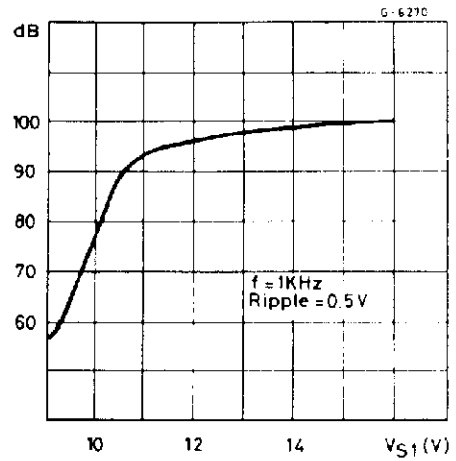

Figure 13: Supply Voltage Rejection vs. V_{S2}

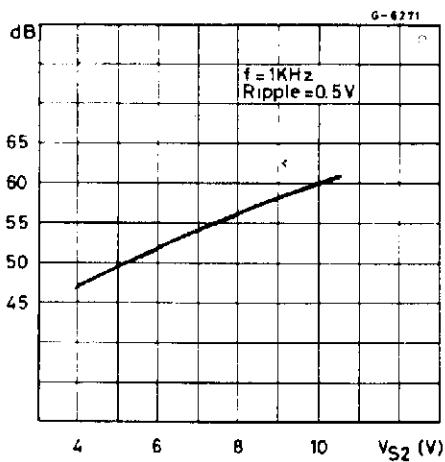
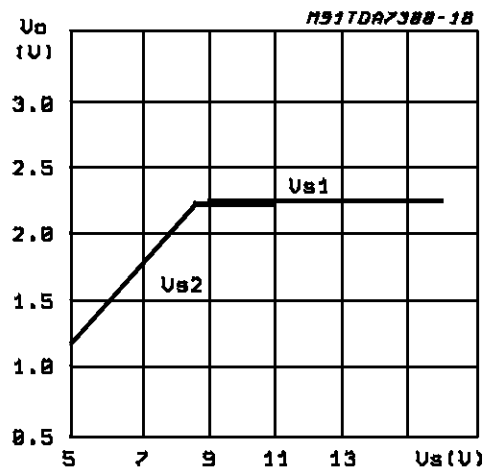

Figure 14: Clipping Level (V_{rms}) vs. Supply Voltage



APPLICATION INFORMATION

Volume Control Concept

Traditional electronic volume control circuits use a multiplier technique with all the disadvantages of high noise and distortion.

The used concept, as shown in Fig. 15 with digital switched resistor dividers, provides extremely low noise and distortion. The multiplexing of the resistive dividers is realized with a multiple-input operational amplifier.

Bass and Treble Control

The principle operation of the bass control is shown in Fig. 16. The external filter together with the internal buffer allows a flexible filter design according to the different requirements in car radios. The function of the treble is similar to the bass. A typical curve is shown in Fig. 19.

Outputs

A special class-A output amplifier with a modulated sink current provides low distortion and ground compatibility with low current consumption.

Figure 15: Volume Control

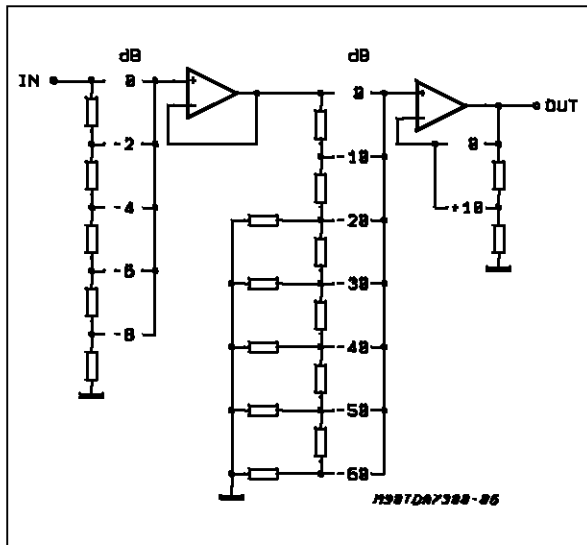

Figure 16: Bass Control

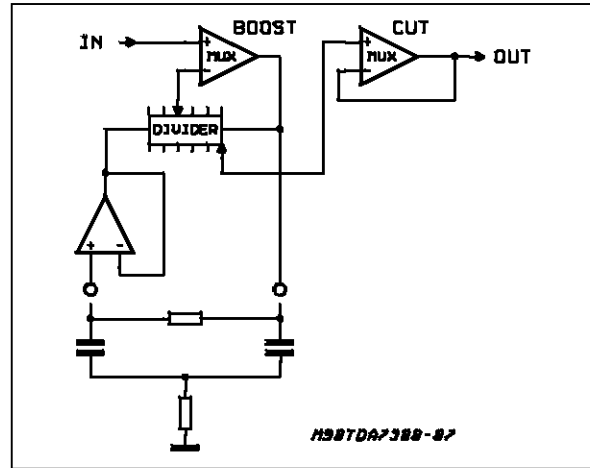

Figure 17: Quiescent Current vs. Supply Voltage

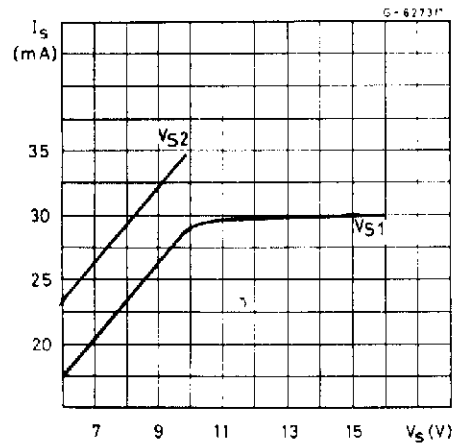
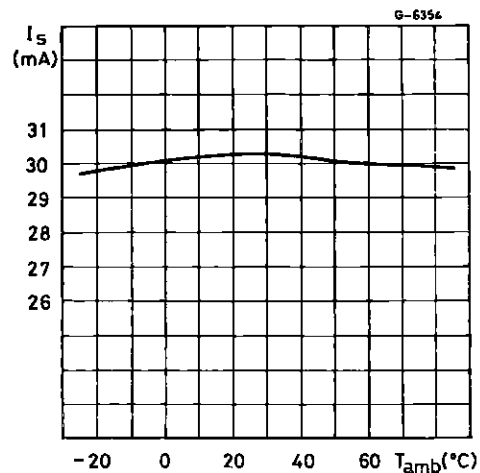

Figure 18: Quiescent Current vs. Temperature



APPLICATION INFORMATION (continued)

Figure 19: Typical Tone Response

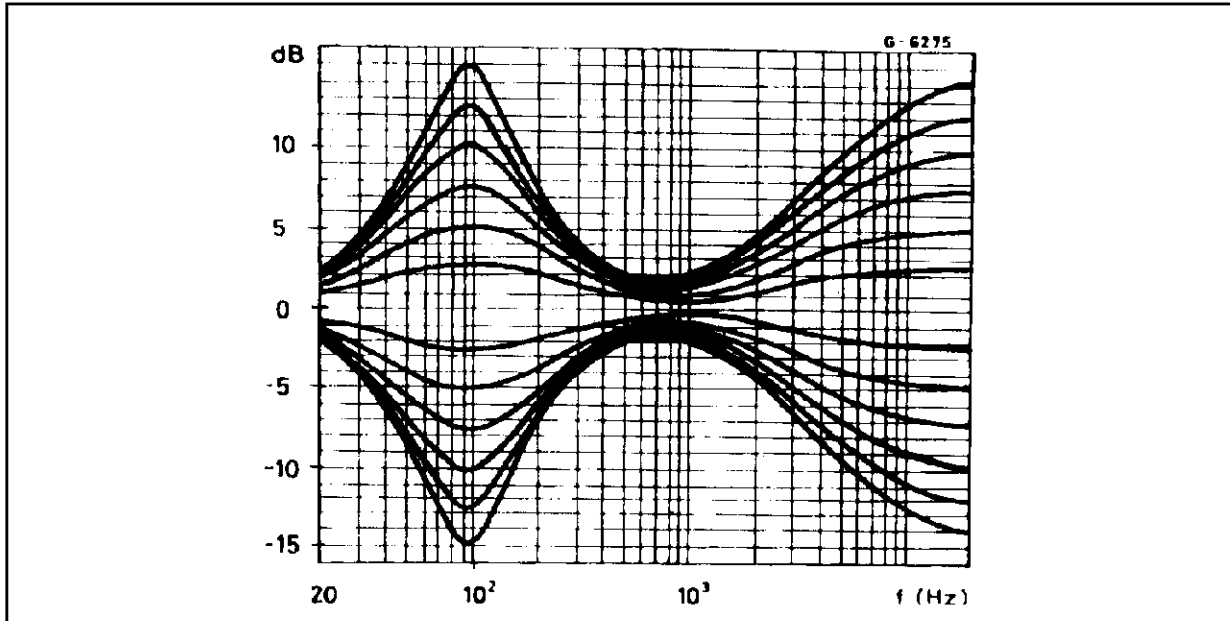
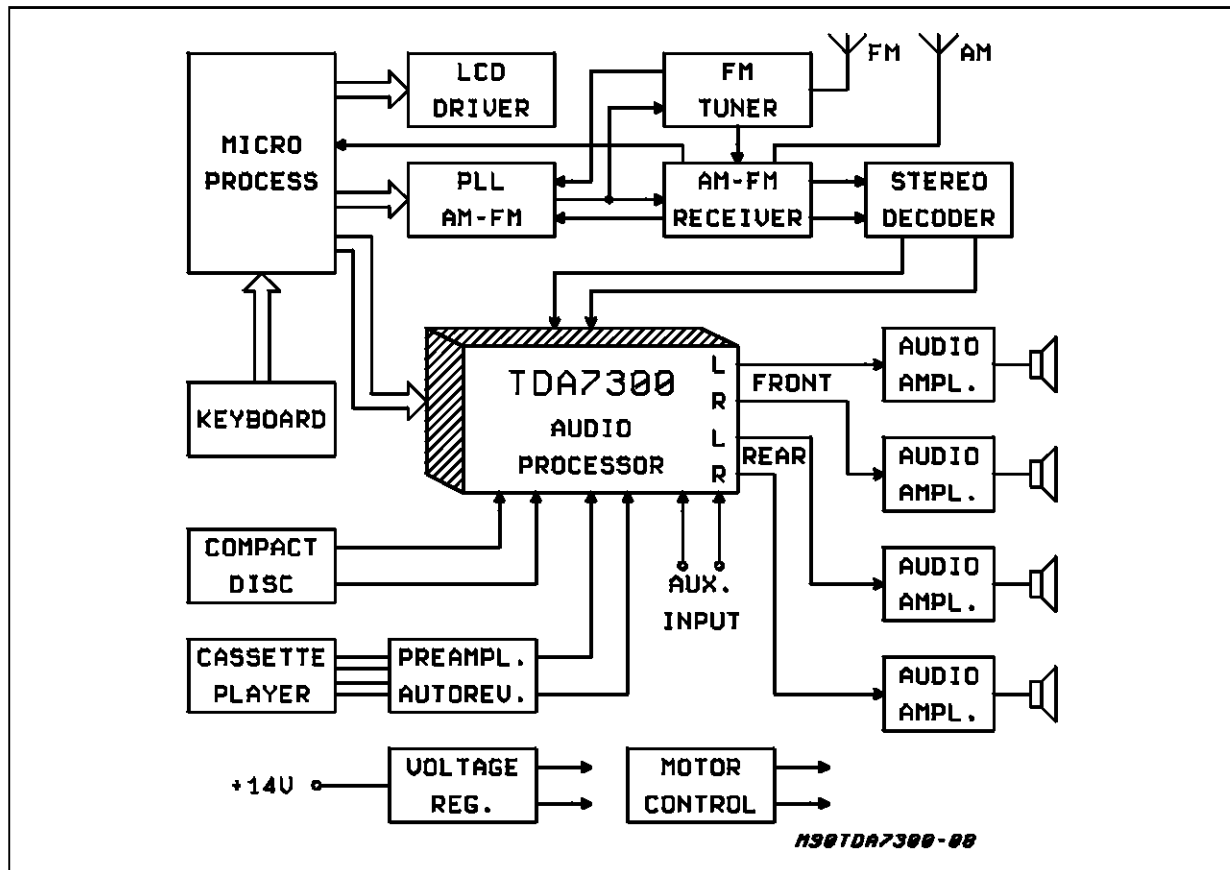

Figure 20: Complete Car-Radio System using Digital Controlled Audio Processor



APPLICATION INFORMATION (continued)

SERIAL BUS INTERFACE

S-BUS Interface and I²C BUS Compatibility

Data transmission from microprocessor to the TDA7300 and viceversa takes place thru the 3-wire S-BUS interface, consisting of the three lines SDA, SCL, SEN. If SDA and SEN inputs are short-circuited together, then the TDA7300 appears as a standard I²C BUS slave.

According to I²C BUS specification the S-BUS lines are connected to a positive supply voltage via pull-up resistors.

LOW transition of the SDA line while SCL is HIGH. The stop condition is a LOW to HIGH transition of the SDA line while SCL is HIGH.

S-bus:

the start/stop conditions (points 1 and 6) are detected exclusively by a transition of the SEN line (1 → 0 / 0 → 1) while the SCL line is at the HIGH level.

The SDA line is only allowed to change during the time the SCL line is low (points 2, 3, 4, 5). After the start information (point 1) the SEN line returns to the HIGH level and remains unchanged for all the time the transmission is performed.

Data Validity

As shown in fig. 21, the data on the SDA line must be stable during the high period of the clock. The HIGH and LOW state of the data line can only change when the clock signal on the SCL line is LOW.

Figure 21: Data Validity on the I²C BUS

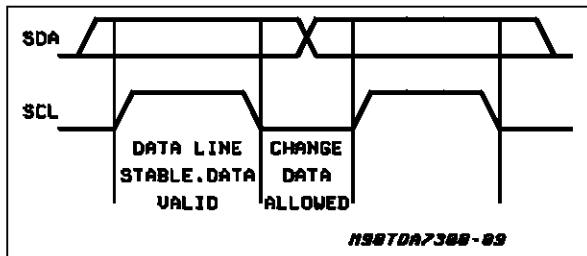

Byte Format

Every byte transferred on the SDA line must contain 8 bits. Each byte must be followed by an acknowledge bit. The MSB is transferred first.

Acknowledge

The master (μP) puts a resistive HIGH level on the SDA line during the acknowledge clock pulse (see fig. 23). The peripheral (audioprocessor) that acknowledges has to pull-down (LOW) the SDA line during the acknowledge clock pulse, so that the SDA line is stable LOW during this clock pulse.

The audioprocessor which has been addressed has to generate an acknowledge after the reception of each byte, otherwise the SDA line remains at the HIGH level during the ninth clock pulse time. In this case the master transmitter can generate the STOP information in order to abort the transfer.

Start and Stop Conditions

I²C BUS:

as shown in fig.22 a start condition is a HIGH to

Figure 22: Timing Diagram of S-BUS and I²C BUS

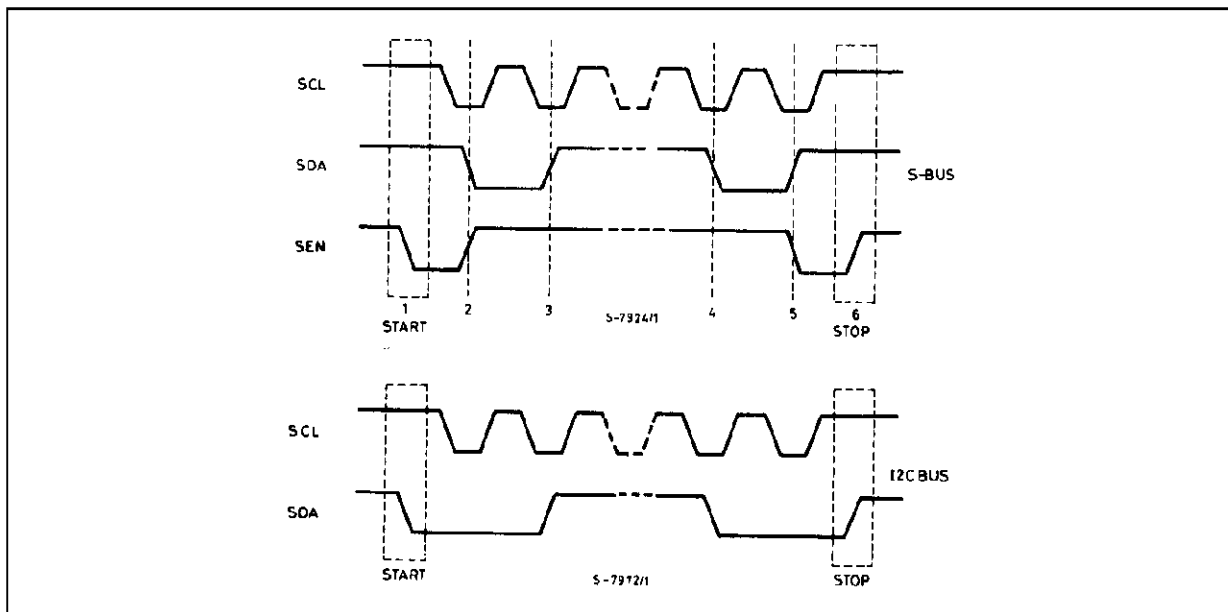

APPLICATION INFORMATION (continued)

Figure 23: Acknowledge on the I²C BUS

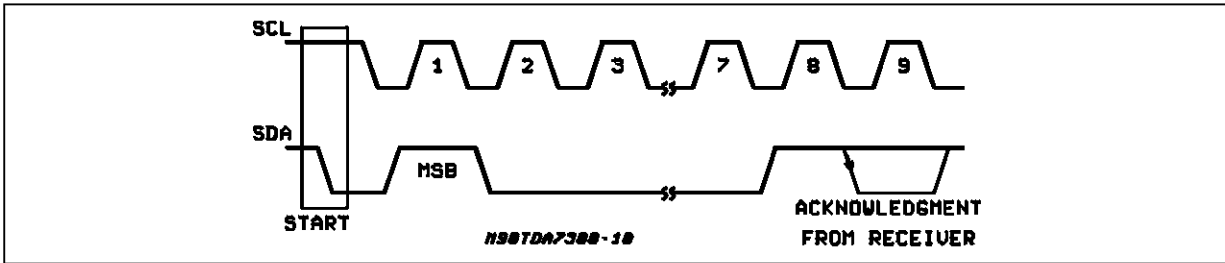

Transmission without Acknowledge

Avoiding to detect the acknowledge of the audio-processor, the μ P can use a simpler transmission: simply it waits one clock without checking the slave acknowledging, and sends the new data.

This approach of course is less protected from misworking and decreases the noise immunity.

Interface Protocol

The interface protocol comprises:

- A start condition (S)
- A chip address byte, containing the TDA7300 address (the 8th bit of the byte must be 0). The TDA7300 must always acknowledge at the end of each transmitted byte.
- A sequence of data (N-bytes + acknowledge)
- A stop condition (P)

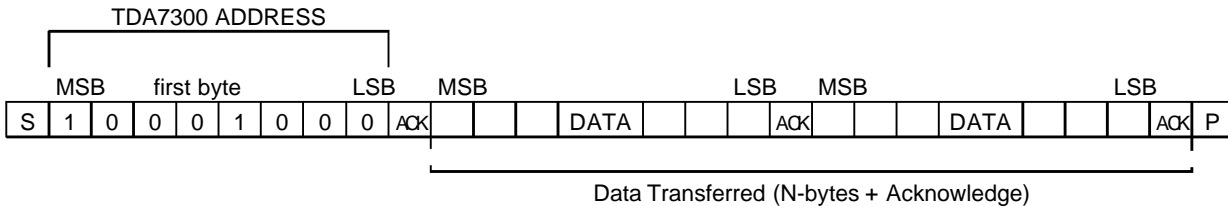

ACK = Acknowledge
S = Start
P = Stop

MAX CLOCK SPEED 100kbts/s

SOFTWARE SPECIFICATION

Chip address (TDA7300 address)

1 0 0 0 1 0 0 0
MSB LSB

DATA BYTES

MSB	LSB							Function
0	0	B2	B1	B0	A2	A1	A0	Volume Control
1	1	0	B1	B0	A2	A1	A0	Speaker ATT LR
1	1	1	B1	B0	A2	A1	A0	Speaker ATT RR
1	0	0	B1	B0	A2	A1	A0	Speaker ATT LF
1	0	1	B1	B0	A2	A1	A0	Speaker ATT RF
0	1	0	X	X	S2	S1	S0	Audio switch
0	1	1	0	C3	C2	C1	C0	Bass control
0	1	1	1	C3	C2	C1	C0	Treble control

X = don't care
Ax = 2dB steps
Bx = 10dB steps
Cx = 2.5dB steps

Status after power-on reset

Volume	-68dB
Speaker	-38dB
Audio Switch	Mono
Bass	+2.5dB
Treble	+2.5dB

TDA7300

SOFTWARE SPECIFICATION (continued) DATA BYTES (detailed description)

VOLUME

MSB			LSB					
0	0	B2	B1	B0	A2	A1	A0	Volume 2dB Steps
					0	0	0	0
					0	0	1	-2
					0	1	0	-4
					0	1	1	-6
					1	0	0	-8
					1	0	1	Not allowed
					1	1	0	Not allowed
					1	1	1	Not allowed
0	0	B2	B1	B0				Volume 10dB steps
		0	0	0				+10
		0	0	1				0
		0	1	0				-10
		0	1	1				-20
		1	0	0				-30
		1	0	1				-40
		1	1	0				-50
		1	1	1				-60

For example if you want setting the volume at -32dB the 8 bit string is: 0 0 1 0 0 0 0 1

SPEAKER ATTENUATORS

MSB			LSB					
1	0	0	B1	B0	A2	A1	A0	Speaker LF
1	0	1	B1	B0	A2	A1	A0	Speaker RF
1	1	0	B1	B0	A2	A1	A0	Speaker LR
1	1	1	B1	B0	A2	A1	A0	Speaker RR
					0	0	0	0
					0	0	1	-2
					0	1	0	-4
					0	1	1	-6
					1	0	0	-8
					1	0	1	Not allowed
					1	1	0	Not allowed
					1	1	1	Not allowed
		0	0				0	
		0	1				-10	
		1	0				-20	
		1	1				-30	

For example attenuation of 24dB on speaker RF is given by: 1 0 1 1 0 0 1 0

SOFTWARE SPECIFICATION (continued)

AUDIO SWITCH - Select the input Channel to Activate

MSB			LSB					
0	1	0	X	X	S2	S1	S0	Audio Switch
			X	X	0	0	0	Stereo 1
			X	X	0	0	1	Stereo 2
			X	X	0	1	0	Stereo 3
			X	X	0	1	1	Stereo 4
			X	X	1	0	0	Mono
			X	X	1	0	1	Not Allowed
			X	X	1	1	0	Not Allowed
			X	X	1	1	1	Not Allowed

X = don't care

For example to set the stereo 2 channel the 8 bit string may be: 0 1 0 0 0 0 1

BASS AND TREBLE - Control Range of ± 15 dB (boost and cut) Steps of 2.5dB

0	1	1	0	C3	C2	C1	C0	Bass Treble
0	1	1	1	C3	C2	C1	C0	
				0	0	0	0	- 15
				0	0	0	1	- 15
				0	0	1	0	- 12.5
				0	0	1	1	- 10
				0	1	0	0	- 7.5
				0	1	0	1	- 5
				0	1	1	0	- 2.5
				0	1	1	1	- 0
				1	1	1	1	0
				1	1	1	0	2.5
				1	1	0	1	5
				1	1	0	0	7.5
				1	0	1	1	10
				1	0	1	0	12.5
				1	0	0	1	15
				1	0	0	0	15

C3 = Sign

For example Bass at -12.5dB is obtained by the following 8 bit string: 0 1 1 0 0 0 1 0

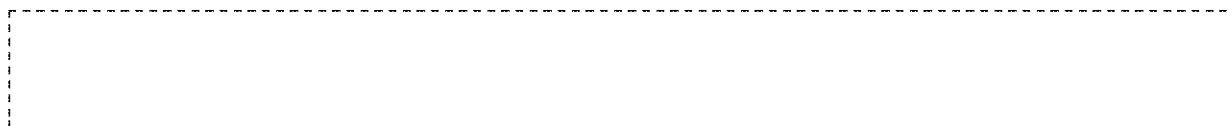

TDA7300

DIP28 PACKAGE MECHANICAL DATA

DIM.	mm			inch		
	MIN.	TYP.	MAX.	MIN.	TYP.	MAX.
a1		0.63			0.025	
b		0.45			0.018	
b1	0.23		0.31	0.009		0.012
b2		1.27			0.050	
D			37.34			1.470
E	15.2		16.68	0.598		0.657
e		2.54			0.100	
e3		33.02			1.300	
F			14.1			0.555
l		4.445			0.175	
L		3.3			0.130	

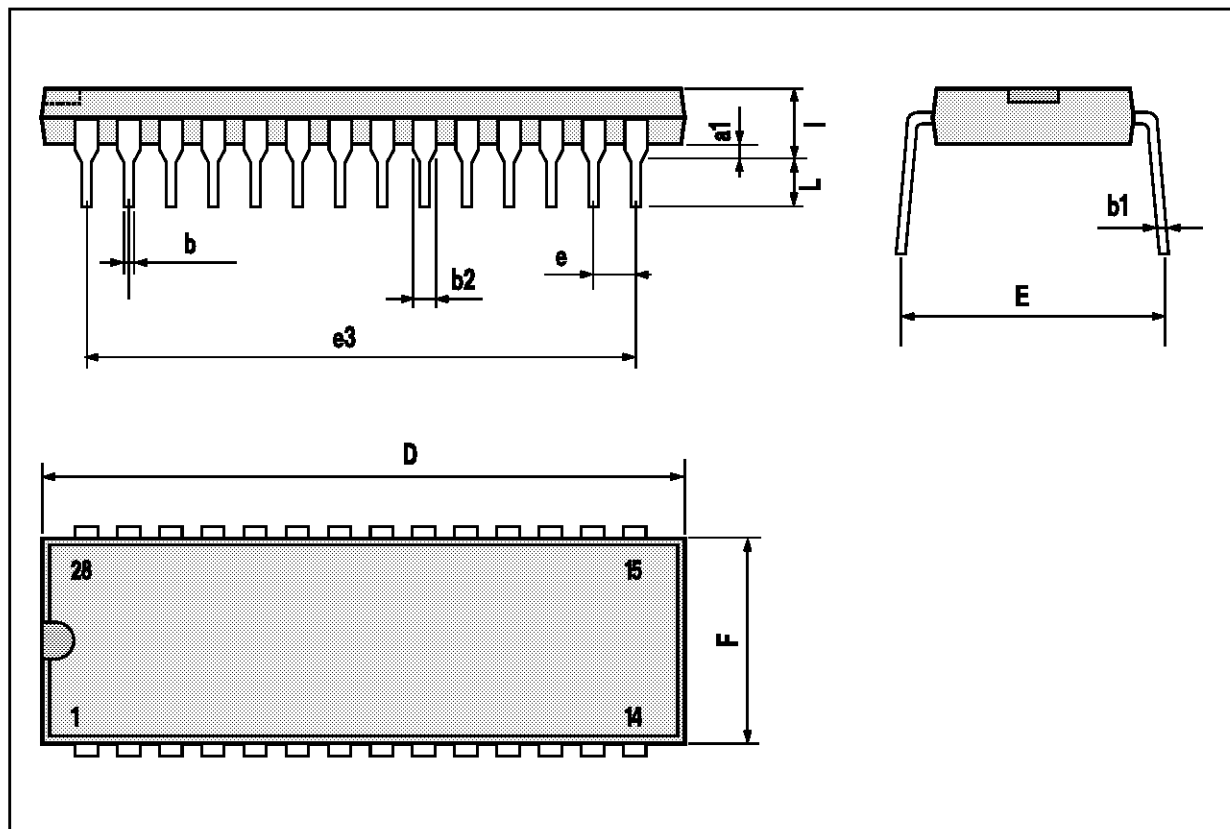

SO28 PACKAGE MECHANICAL DATA

DIM.	mm			inch		
	MIN.	TYP.	MAX.	MIN.	TYP.	MAX.
A			2.65			0.104
a1	0.1		0.3	0.004		0.012
b	0.35		0.49	0.014		0.019
b1	0.23		0.32	0.009		0.013
C		0.5			0.020	
c1	45° (typ.)					
D	17.7		18.1	0.697		0.713
E	10		10.65	0.394		0.419
e		1.27			0.050	
e3		16.51			0.65	
F	7.4		7.6	0.291		0.299
L	0.4		1.27	0.016		0.050
S	8° (max.)					

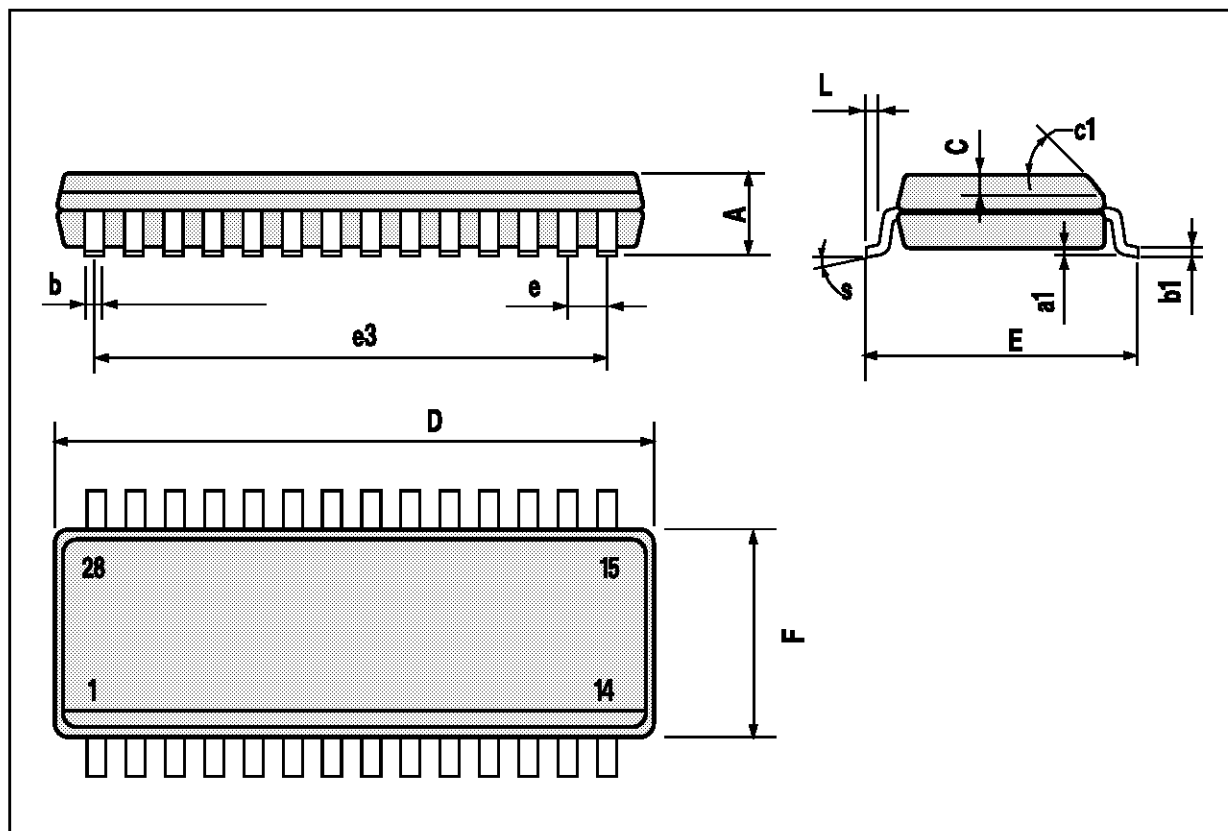

Information furnished is believed to be accurate and reliable. However, SGS-THOMSON Microelectronics assumes no responsibility for the consequences of use of such information nor for any infringement of patents or other rights of third parties which may result from its use. No license is granted by implication or otherwise under any patent or patent rights of SGS-THOMSON Microelectronics. Specifications mentioned in this publication are subject to change without notice. This publication supersedes and replaces all information previously supplied. SGS-THOMSON Microelectronics products are not authorized for use as critical components in life support devices or systems without express written approval of SGS-THOMSON Microelectronics.

© 1994 SGS-THOMSON Microelectronics - All Rights Reserved

Purchase of I²C Components of SGS-THOMSON Microelectronics, conveys a license under the Philips I²C Patent Rights to use these components in an I²C system, provided that the system conforms to the I²C Standard Specifications as defined by Philips.

SGS-THOMSON Microelectronics GROUP OF COMPANIES

Australia - Brazil - France - Germany - Hong Kong - Italy - Japan - Korea - Malaysia - Malta - Morocco - The Netherlands - Singapore - Spain - Sweden - Switzerland - Taiwan - Thailand - United Kingdom - U.S.A.