

DM54L73 Dual Master-Slave J-K Flip-Flops with Clear and Complementary Outputs

General Description

This device contains two independent positive pulse triggered J-K flip-flops with complementary outputs. The J and K data is processed by the flip-flops after a complete clock pulse. While the clock is low the slave is isolated from the master. On the positive transition of the clock, the data from the J and K inputs is transferred to the master. While the clock is high, the data from the J and K inputs are

disabled. On the negative transition of the clock, the data from the master is transferred to the slave. The logic states of the J and K inputs must not be allowed to change while the clock is high. Data is transferred to the outputs on the falling edge of the clock pulse. A low logic level on the clear input will reset the outputs regardless of the logic states of the other inputs.



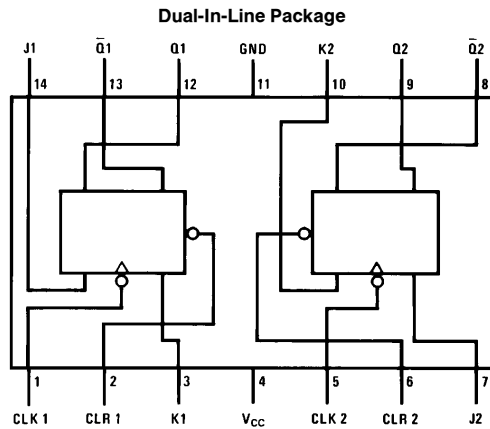

Connection Diagram



TL/F/6630-1

Order Number DM54L73J or DM54L73W
See NS Package Number J14A or W14B

Function Table

Inputs				Outputs	
CLR	CLK	J	K	Q	\bar{Q}
L	X	X	X	L	H
H		L	L	Q_0	\bar{Q}_0
H		H	L	H	L
H		L	H	L	H
H		H	H	Toggle	

H = High Logic Level

X = Either Low or High Logic Level

L = Low Logic Level

 = Positive pulse data. The J and K inputs must be held constant while the clock is high. Data is transferred to the outputs on the falling edge of the clock pulse.

Q_0 = The output logic level before the indicated input conditions were established.

Toggle = Each output changes to the complement of its previous level on each complete high level clock pulse.

Absolute Maximum Ratings (Note)

If Military/Aerospace specified devices are required, please contact the National Semiconductor Sales Office/Distributors for availability and specifications.

Supply Voltage	8V
Input Voltage	5.5V
Storage Temperature Range	−65°C to +150°C
Operating Free Air Temperature Range DM54L	−55°C to +125°C

Note: The “Absolute Maximum Ratings” are those values beyond which the safety of the device can not be guaranteed. The device should not be operated at these limits. The parametric values defined in the “Electrical Characteristics” table are not guaranteed at the absolute maximum ratings. The “Recommended Operating Conditions” table will define the conditions for actual device operation.

Recommended Operating Conditions

Symbol	Parameter		DM54L73			Units
			Min	Nom	Max	
V _{CC}	Supply Voltage		4.5	5	5.5	V
V _{IH}	High Level Input Voltage		2			V
V _{IL}	Low Level Input Voltage	Clock			0.6	V
		Others			0.7	
I _{OH}	High Level Output Current				−0.2	mA
I _{OL}	Low Level Output Current				2	mA
f _{CLK}	Clock Frequency (Note 2)		0		6	MHz
t _w	Pulse Width (Note 2)	Clock High	100			ns
		Clock Low	100			
		Clear Low	100			
t _{SU}	Input Setup Time (Notes 1 & 2)		0 ↑			ns
t _H	Input Hold Time (Notes 1 & 2)		0 ↓			ns
T _A	Free Air Operating Temperature		−55		125	°C

Note 1: The symbols (↑, ↓) indicate the edge of the clock pulse used for reference: ↑ for rising edge, ↓ for falling edge.

Note 2: T_A = 25°C and V_{CC} = 5V.

Electrical Characteristics over recommended operating free air temperature (unless otherwise noted)

Symbol	Parameter	Conditions	Min	Typ (Note 1)	Max	Units
V_{OH}	High Level Output Voltage	$V_{CC} = \text{Min}, I_{OH} = \text{Max}$ $V_{IL} = \text{Max}, V_{IH} = \text{Min}$	2.4	3.3		V
V_{OL}	Low Level Voltage	$V_{CC} = \text{Min}, I_{OL} = \text{Max}$ $V_{IL} = \text{Max}, V_{IH} = \text{Min}$		0.15	0.3	V
I_I	Input Current @ Max Input Voltage	$V_{CC} = \text{Max}$ $V_I = 5.5V$	J, K		100	μA
			Clear		200	
			Clock		200	
I_{IH}	High Level Input Current	$V_{CC} = \text{Max}$ $V_I = 2.4V$	J, K		10	μA
			Clear		20	
			Clock		-200	
I_{IL}	Low Level Input Current	$V_{CC} = \text{Max}$ $V_I = 0.3V$	J, K		-0.18	mA
			Clear		-0.36	
			Clock		-0.36	
I_{OS}	Short Circuit Output Current	$V_{CC} = \text{Max}$	-3		-15	mA
I_{CC}	Supply Current	$V_{CC} = \text{Max}$ (Note 2)		1.5	2.88	mA

Note 1: All typicals are at $V_{CC} = 5V, T_A = 25^\circ\text{C}$.

Note 2: With all outputs open, I_{CC} is measured with the Q and \bar{Q} outputs high in turn. At the time of measurement, the clock is grounded.

Switching Characteristics $V_{CC} = 5V$ and $T_A = 25^\circ\text{C}$ (See Section 1 for Test Waveforms and Output Load)

Symbol	Parameter	From (Input) To (Output)	$R_L = 4\text{ k}\Omega, C_L = 50\text{ pF}$		Units
			Min	Max	
f_{MAX}	Maximum Clock Frequency		6		MHz
t_{PHL}	Propagation Delay Time High to Low Level Output	Clear to Q		150	ns
t_{PLH}	Propagation Delay Time Low to High Level Output	Clear to \bar{Q}		75	ns
t_{PLH}	Propagation Delay Time Low to High Level Output	Clock to Q or \bar{Q}	10	75	ns
t_{PHL}	Propagation Delay Time High to Low Level Output	Clock to Q or \bar{Q}	10	150	ns

This datasheet has been downloaded from:

www.DatasheetCatalog.com

Datasheets for electronic components.

National Semiconductor was acquired by Texas Instruments.

http://www.ti.com/corp/docs/investor_relations/pr_09_23_2011_national_semiconductor.html

This file is the datasheet for the following electronic components:

DM54L73W - <http://www.ti.com/product/dm54l73w?HQS=TI-null-null-dscatalog-df-pf-null-ww>

DM54L73J - <http://www.ti.com/product/dm54l73j?HQS=TI-null-null-dscatalog-df-pf-null-ww>



LittleDiode supplies new, hard to find or obsolete electronic components and semiconductors all over the world.

With over two million different components listed you are sure to find the part you need.

Feel free to visit us today at our online store:

LittleDiode.com

Looking forward to providing you with the best possible service.