



Features

- ◆ High-speed (equal access and cycle time)
 - Military: 25/35/45/55/70/85/100ns (max.)
 - Commercial: 15/20/25ns (max.)
- ◆ Low power consumption
- ◆ Battery backup operation — 2V data retention voltage (IDT6167LA only)
- ◆ Available in 20-pin CERDIP and Plastic DIP, and 20-pin SOJ
- ◆ Produced with advanced CMOS high-performance technology
- ◆ CMOS process virtually eliminates alpha particle soft-error rates
- ◆ Separate data input and output
- ◆ Military product compliant to MIL-STD-883, Class B

Description

The IDT6167 is a 16,384-bit high-speed static RAM organized as 16K x 1. The part is fabricated using IDT's high-performance,

high reliability CMOS technology.

Access times as fast as 15ns are available. The circuit also offers a reduced power standby mode. When \overline{CS} goes HIGH, the circuit will automatically go to, and remain in, a standby mode as long as \overline{CS} remains HIGH. This capability provides significant system-level power and cooling savings. The low-power (LA) version also offers a battery backup data retention capability where the circuit typically consumes only 1 μ W operating off a 2V battery.

All inputs and the output of the IDT6167 are TTL-compatible and operate from a single 5V supply, thus simplifying system designs.

The IDT6167 is packaged in a space-saving 20-pin, 300 mil Plastic DIP or CERDIP and a Plastic 20-pin providing high board-level packing densities.

Military grade product is manufactured in compliance with the latest revision of MIL-STD-883, Class B, making it ideally suited to military temperature applications demanding the highest level of performance and reliability.

Functional Block Diagram

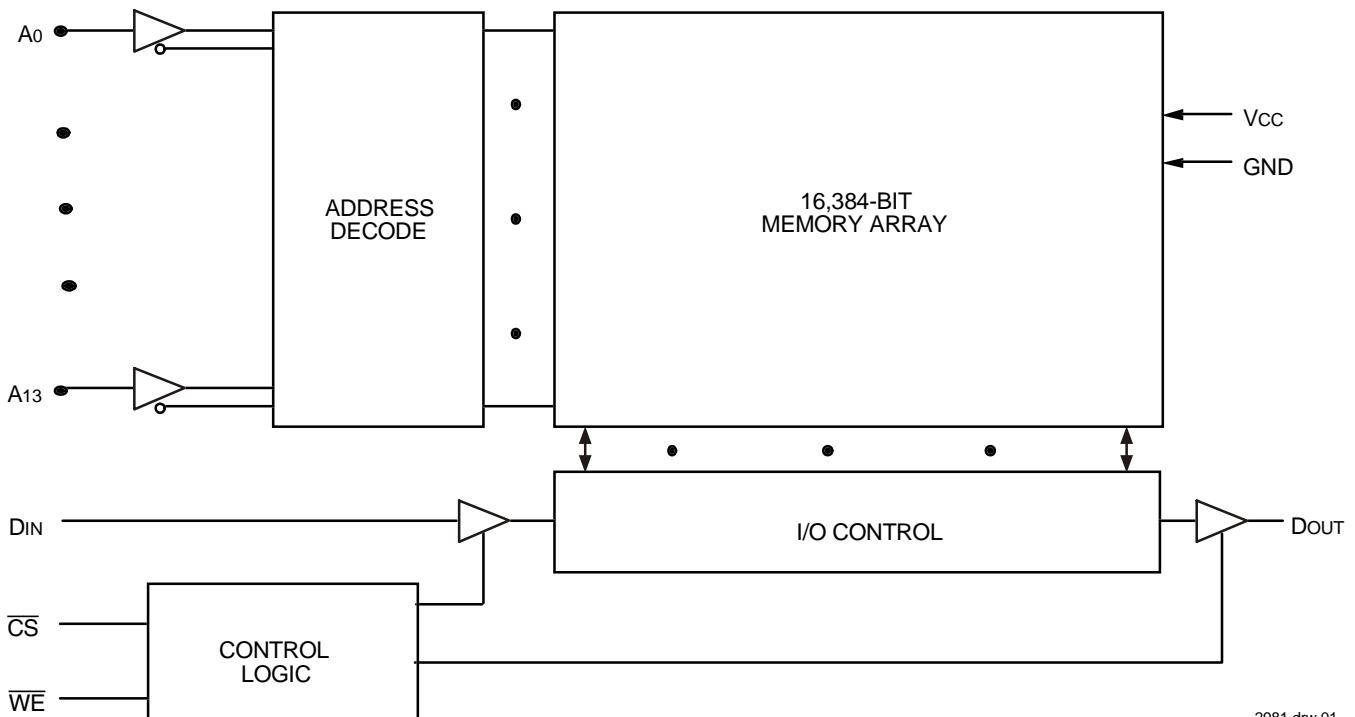

2981 drw 01

Pin Configurations

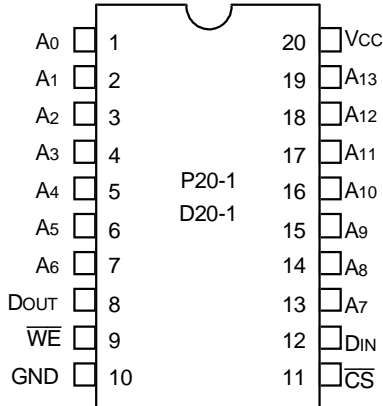

DIP
Top View

2981 drw 02

Pin Descriptions

Name	Description
A ₀ - A ₁₃	Address Inputs
\overline{CS}	Chip Select
\overline{WE}	Write Enable
V _{CC}	Power
D _{IN}	DATA _{IN}
D _{OUT}	DATA _{OUT}
GND	Ground

2981 tbl 01

Truth Table⁽¹⁾

Mode	\overline{CS}	\overline{WE}	Output	Power
Standby	H	X	High-Z	Standby
Read	L	H	DATA _{OUT}	Active
Write	L	L	High-Z	Active

2981 tbl 02

NOTE:

1. H = V_{IH}, L = V_{IL}, X = Don't Care.

Recommended Operating Temperature and Supply Voltage

Grade	Temperature	GND	V _{CC}
Military	-55°C to +125°C	0V	5V ± 10%
Commercial	0°C to +70°C	0V	5V ± 10%

2981 tbl 06

Absolute Maximum Ratings⁽¹⁾

Symbol	Rating	Com'l.	Mil.	Unit
V _{TERM}	Terminal Voltage with Respect to GND	-0.5 to +7.0	-0.5 to +7.0	V
T _A	Operating Temperature	0 to +70	-55 to +125	°C
T _{BIAS}	Temperature Under Bias	-55 to +125	-65 to +135	°C
T _{STG}	Storage Temperature	-55 to +125	-65 to +150	°C
P _T	Power Dissipation	1.0	1.0	W
I _{OUT}	DC Output Current	50	50	mA

2981 tbl 03

NOTE:

1. Stresses greater than those listed under ABSOLUTE MAXIMUM RATINGS may cause permanent damage to the device. This is a stress rating only and functional operation of the device at these or any other conditions above those indicated in the operational sections of this specification is not implied. Exposure to absolute maximum rating conditions for extended periods may affect reliability.

Capacitance (T_A = +25°C, f = 1.0MHz)

Symbol	Parameter ⁽¹⁾	Conditions	Max.	Unit
C _{IN}	Input Capacitance	V _{IN} = 0V	7	pF
C _{OUT}	Output Capacitance	V _{OUT} = 0V	7	pF

2981 tbl 04

NOTE:

1. This parameter is determined by device characterization, but is not production tested.

Recommended DC Operating Conditions

Symbol	Parameter	Min.	Typ.	Max.	Unit
V _{CC}	Supply Voltage	4.5	5.0	5.5	V
GND	Ground	0	0	0	V
V _{IH}	Input High Voltage	2.2	—	6.0	V
V _{IL}	Input Low Voltage	-0.5 ⁽¹⁾	—	0.8	V

2981 tbl 05

NOTE:

1. V_{IL} (min.) = -3.0V for pulse width less than 20ns, once per cycle.

DC Electrical Characteristics⁽¹⁾

(V_{CC} = 5.0V ± 10%, V_{LC} = 0.2V, V_{HC} = V_{CC} - 0.2V)

Symbol	Parameter	Power	6167SA/LA15	6167SA/LA20	6167SA/LA25		Unit
			Com'l.	Com'l.	Com'l.	Mil.	
ICC1	Operating Power Supply Current CS ≤ V _{IL} , Outputs Open V _{CC} = Max., f = 0 ⁽³⁾	SA	90	90	90	90	mA
		LA	55	55	55	60	
ICC2	Dynamic Operating Current CS ≤ V _{IL} , Outputs Open V _{CC} = Max., f = f _{MAX} ⁽³⁾	SA	120	100	100	100	mA
		LA	100	80	70	75	
ISB	Standby Power Supply Current (TTL Level) CS ≥ V _{IH} , Outputs Open V _{CC} = Max., f = f _{MAX} ⁽³⁾	SA	50	35	35	35	mA
		LA	35	30	25	25	
ISB1	Full Standby Power Supply Current (CMOS Level) CS ≥ V _{HC} , V _{CC} = Max., VIN ≥ V _{HC} or VIN ≤ V _{LC} , f = 0 ⁽³⁾	SA	5	5	5	10	mA
		LA	0.9	0.05	0.05	0.9	

2981 tbl 07

DC Electrical Characteristics⁽¹⁾ (con't.)

(V_{CC} = 5.0V ± 10%, V_{LC} = 0.2V, V_{HC} = V_{CC} - 0.2V)

Symbol	Parameter	Power	6167SA/LA35 ⁽²⁾	6167SA/LA45 ⁽²⁾	6167SA/LA55 ⁽²⁾	6167SA/LA70 ⁽²⁾	Unit
			Mil.	Mil.	Mil.	Mil.	
ICC1	Operating Power Supply Current CS ≤ V _{IL} , Outputs Open V _{CC} = Max., f = 0 ⁽³⁾	SA	90	90	90	90	mA
		LA	60	60	60	60	
ICC2	Dynamic Operating Current CS ≤ V _{IL} , Outputs Open V _{CC} = Max., f = f _{MAX} ⁽³⁾	SA	100	100	100	100	mA
		LA	70	65	60	60	
ISB	Standby Power Supply Current (TTL Level) CS ≥ V _{IH} , Outputs Open V _{CC} = Max., f = f _{MAX} ⁽³⁾	SA	35	35	35	35	mA
		LA	20	20	20	15	
ISB1	Full Standby Power Supply Current (CMOS Level) CS ≥ V _{HC} , V _{CC} = Max., VIN ≥ V _{HC} or VIN ≤ V _{LC} , f = 0 ⁽³⁾	SA	10	10	10	10	mA
		LA	0.9	0.9	0.9	0.9	

2981 tbl 08

NOTES:

1. All values are maximum guaranteed values.
2. -55°C to +125°C temperature range only. Also available; 85ns and 100ns Military devices.
3. f_{MAX} = 1/trc, only address inputs cycling at f_{MAX}. f = 0 means no address inputs change.

DC Electrical Characteristics

(V_{CC} = 5.0V ± 10%)

Symbol	Parameter	Test Conditions	IDT6167SA		IDT6167LA		Unit	
			Min.	Max.	Min.	Max.		
I _{IL}	Input Leakage Current	V _{CC} = Max., V _{IN} = GND to V _{CC}	MIL. COM'L.	— —	10 5	— —	5 2	μA
I _{LO}	Output Leakage Current	V _{CC} = Max., $\overline{CS} = V_{IH}$, V _{OUT} = GND to V _{CC}	MIL. COM'L.	— —	10 5	— —	5 2	μA
V _{OL}	Output Low Voltage	I _{OL} = 8mA, V _{CC} = Min.		—	0.4	—	0.4	V
V _{OH}	Output High Voltage	I _{OH} = -4mA, V _{CC} = Min.		2.4	—	2.4	—	V

2981 tbl 09

Data Retention Characteristics Over All Temperature Ranges

(LA Version Only) (V_{LC} = 0.2V, V_{HC} = V_{CC} - 0.2V)

Symbol	Parameter	Test Condition	Min.	Typ. ⁽¹⁾ V _{CC} @		Max. V _{CC} @		Unit
				2.0V	3.0V	2.0V	3.0V	
V _{DR}	V _{CC} for Data Retention	—	2.0	—	—	—	—	V
I _{CCDR}	Data Retention Current	MIL. COM'L.	— —	0.5 0.5	1.0 1.0	200 20	300 30	μA
t _{CDR}	Chip Deselect to Data Retention Time	$\overline{CS} \geq V_{HC}$ V _{IN} ≥ V _{HC} or ≤ V _{LC}	0	—	—	—	—	ns
t _R ⁽²⁾	Operation Recovery Time		t _{RC} ⁽²⁾	—	—	—	—	ns
I _{IL} ⁽³⁾	Input Leakage Current		—	—	—	2	2	μA

2981 tbl 10

NOTES:

- TA = +25°C.
- t_{RC} = Read Cycle Time.
- This parameter is guaranteed by device characterization, but is not production tested.

Low V_{CC} Data Retention Waveform

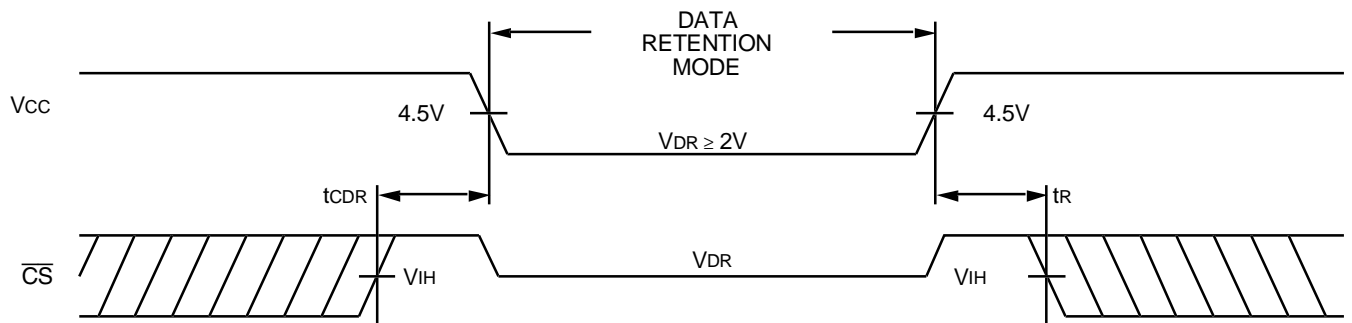

2981 drw 03

AC Test Conditions

Input Pulse Levels	GND to 3.0V
Input Rise/Fall Times	5ns
Input Timing Reference Levels	1.5V
Output Reference Levels	1.5V
AC Test Load	See Figures 1 and 2

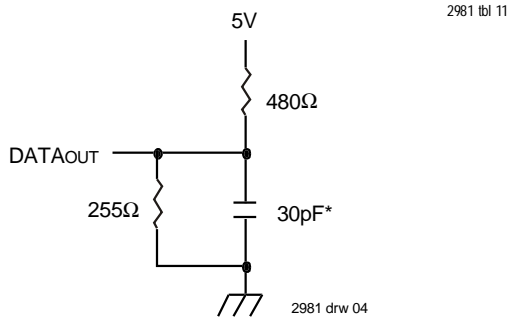

Figure 1. AC Test Load

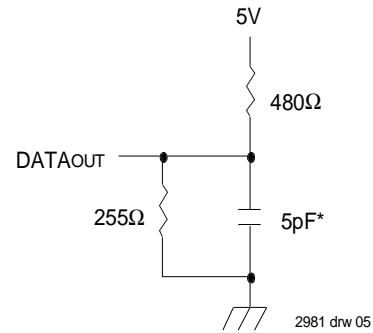

Figure 2. AC Test Load
(for tCLZ, tCHZ, tWHZ and tOW)

*Includes scope and jig.

AC Electrical Characteristics (Vcc = 5.0V ± 10%, All Temperature Ranges)

Symbol	Parameter	6167SA15 ⁽³⁾		6167SA20 ⁽³⁾ /25 6167LA20 ⁽³⁾ /25		6167SA35 ⁽¹⁾ /45 ⁽¹⁾ 6167LA35 ⁽¹⁾ /45 ⁽¹⁾		6167SA55 ⁽¹⁾ /70 ⁽¹⁾ 6167LA55 ⁽¹⁾ /70 ⁽¹⁾		Unit
		Min.	Max.	Min.	Max.	Min.	Max.	Min.	Max.	
Read Cycle										
t _{RC}	Read Cycle Time	15	—	20/25	—	35/45	—	55/70	—	ns
t _{AA}	Address Access Time	—	15	—	20/25	—	35/45	—	55/70	ns
t _{ACS}	Chip Select Access Time	—	15	—	20/25	—	35/45	—	55/70	ns
t _{CLZ} ⁽²⁾	Chip Deselect to Output in Low-Z	3	—	5/5	—	5/5	—	5/5	—	ns
t _{CHZ} ⁽²⁾	Chip Select to Output in High-Z	—	10	—	10/10	—	15/30	—	40/40	ns
t _{OH}	Output Hold from Address Change	3	—	5/5	—	5/5	—	5/5	—	ns
t _{PU} ⁽²⁾	Chip Select to Power-Up Time	0	—	0/0	—	0/0	—	0/0	—	ns
t _{PD} ⁽²⁾	Chip Deselect to Power-Down Time	—	15	—	20/25	—	35/45	—	55/70	ns
Write Cycle										
t _{WC}	Write Cycle Time	15	—	20/20	—	30/45	—	55/70	—	ns
t _{CW}	Chip Select to End-of-Write	15	—	15/20	—	30/40	—	45/55	—	ns
t _{AW}	Address Valid to End-of-Write	15	—	15/20	—	30/40	—	45/55	—	ns
t _{AS}	Address Set-up Time	0	—	0/0	—	0/0	—	0/0	—	ns
t _{WP}	Write Pulse Width	13	—	15/20	—	30/30	—	35/40	—	ns
t _{WR}	Write Recovery Time	0	—	0/0	—	0/0	—	0/0	—	ns
t _{DW}	Data Valid to End-of-Write	10	—	12/15	—	17/20	—	25/30	—	ns
t _{DH}	Data Hold Time	0	—	0/0	—	0/0	—	0/0	—	ns
t _{WHZ} ⁽²⁾	Write Enable to Output in High-Z	—	7	—	8/8	—	15/30	—	40/40	ns
t _{OW} ⁽²⁾	Output Active from End-of-Write	0	—	0/0	—	0/0	—	0/0	—	ns

2981 tbl 12

NOTES:

1. -55°C to +125°C temperature range only. Also available: 85ns and 100ns Military devices.
2. This parameter is guaranteed with AC Load (Figure 2) by device characterization, but is not production tested.
3. 0°C to +70°C temperature range only.

Timing Waveform of Read Cycle No. 1(1, 2)

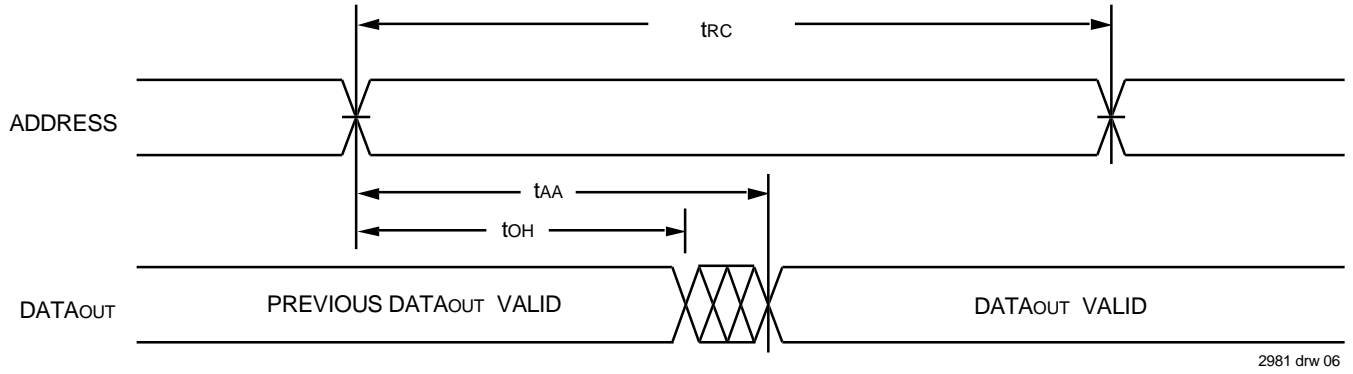

Timing Waveform of Read Cycle No. 2(1, 3)

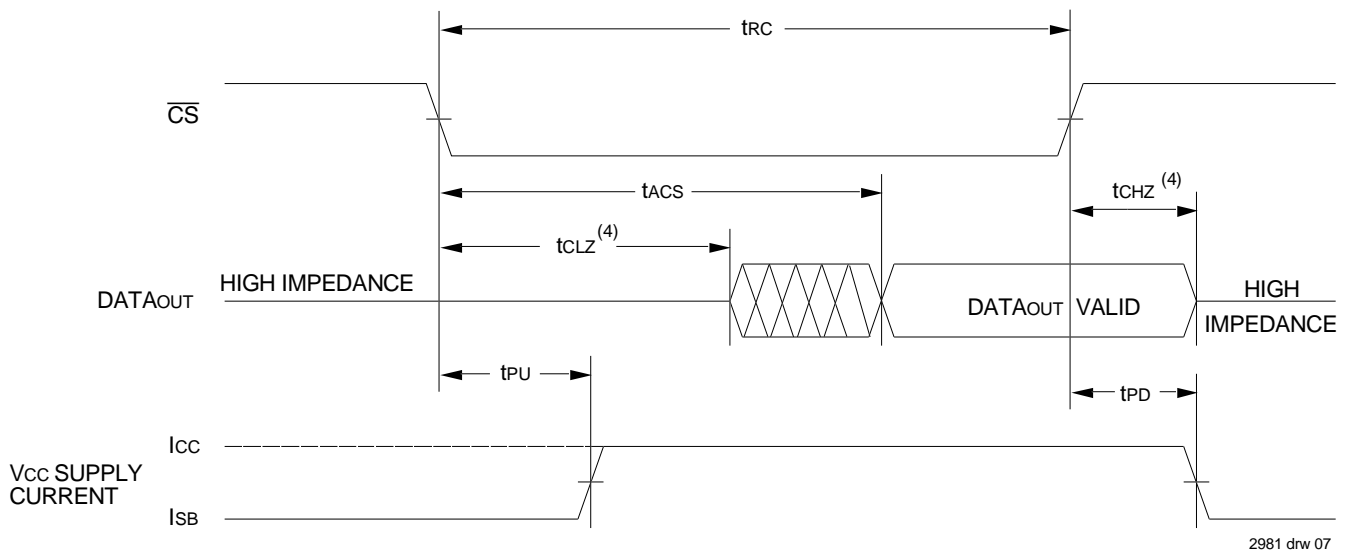

NOTES:

1. \overline{WE} is HIGH for Read cycle.
2. Device is continuously selected, \overline{CS} is LOW.
3. Address valid prior to or coincident with \overline{CS} transition LOW.
4. Transition is measured $\pm 200mV$ from steady state.

Timing Waveform of Write Cycle No. 1 (\overline{WE} Controlled Timing)^(1,3)

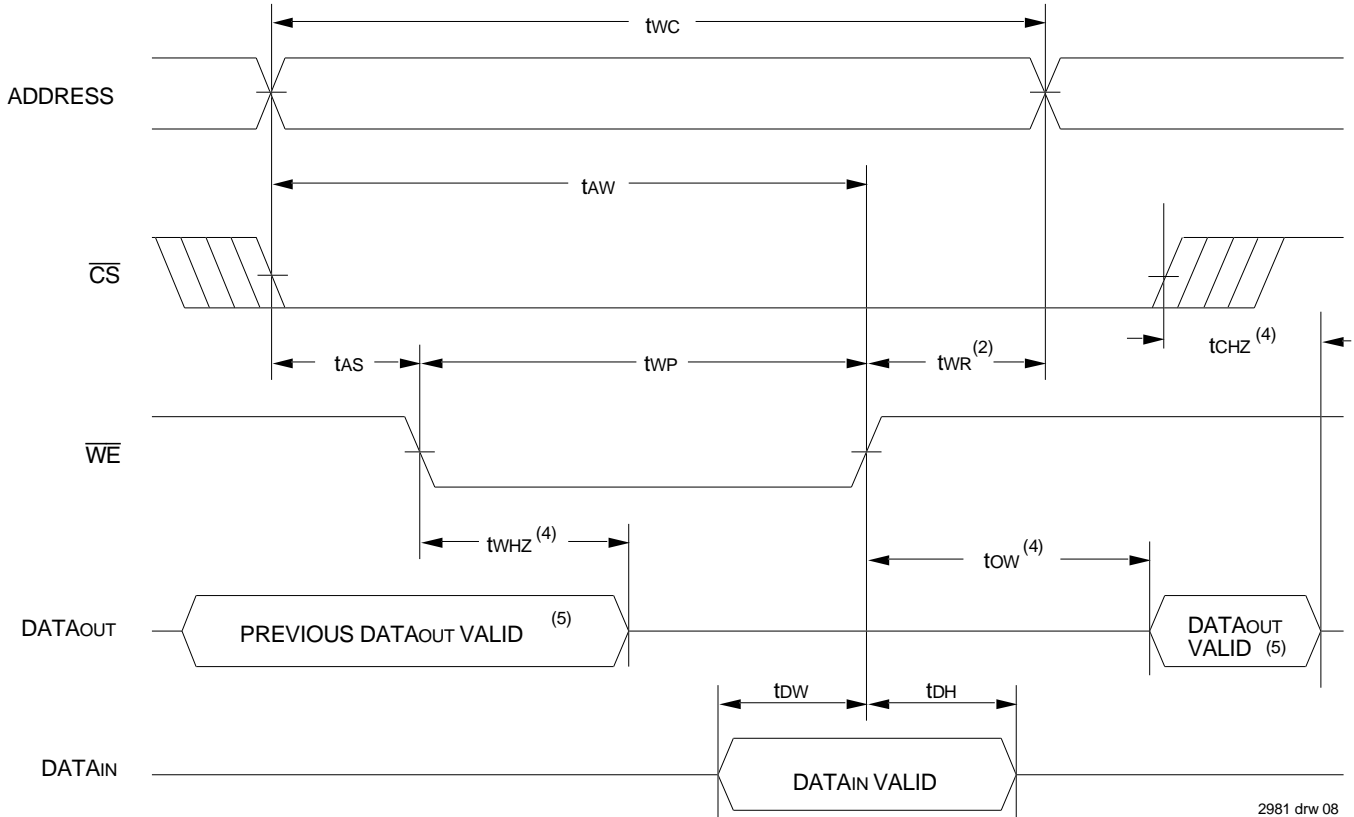

Timing Waveform of Write Cycle No. 2 (\overline{CS} Controlled Timing)^(1,3)

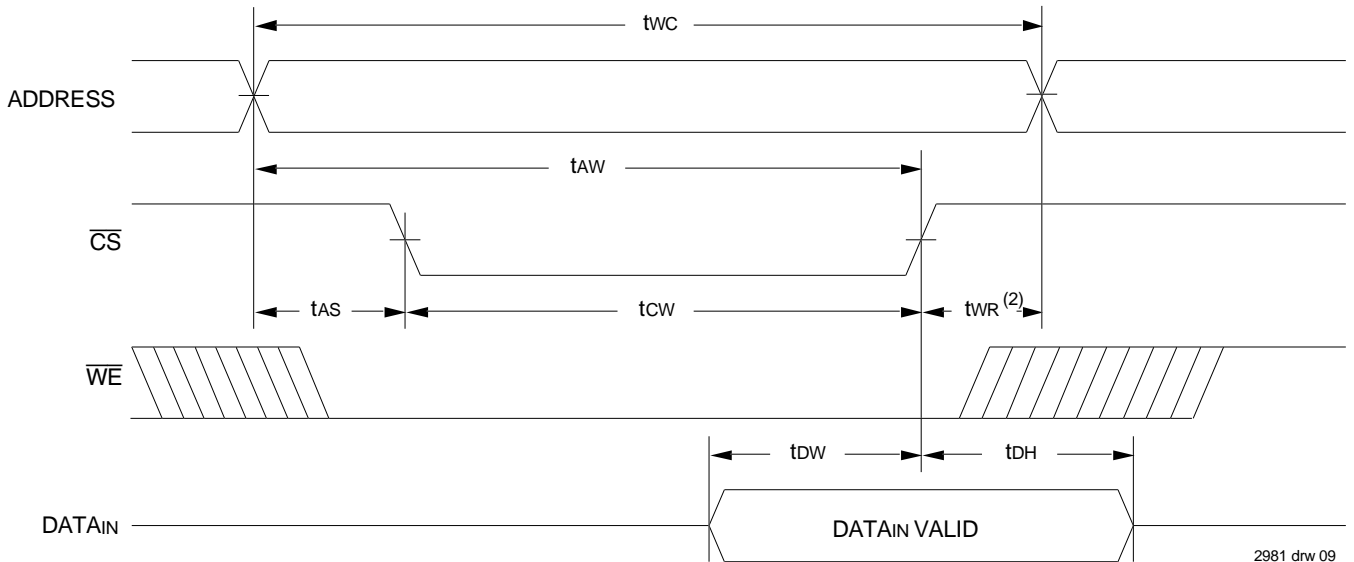

NOTES:

1. A write occurs during the overlap of a LOW \overline{CS} and a LOW \overline{WE} .
2. t_{WR} is measured from the earlier of \overline{CS} or \overline{WE} going HIGH to the end of the write cycle.
3. If the \overline{CS} low transition occurs simultaneously with or after the \overline{WE} LOW transition, the outputs remain in the high-impedance state.
4. Transition is measured $\pm 200\text{mV}$ from steady state.
5. During this period, the I/O pins are in the output state and the input signals must not be applied.

Datasheet Document History

1/13/2000		Updated to new format
	Pg. 7	Removed Note 1 from Write Cycle No. 1 and No. 2 drawings; renumbered notes and footnotes
	Pg. 8	Added Datasheet Document History
1/26/2000	Pg. 1-3, 5, 8	Removed speed offering 15ns and 20ns for military and 35ns for commercial temperature range.
	Pg. 1, 2, 8	Removed SOJ package offering.
	Pg. 9	Updated Datasheet History
08/09/00		Not recommended for new designs
02/01/01		Removed "Not recommended for new designs"



CORPORATE HEADQUARTERS
2975 Stender Way
Santa Clara, CA 95054

for SALES:
800-345-7015 or 408-727-6116
fax:408-492-8674
www.idt.com

for Tech Support:
sramhelp@idt.com
800 544-7726, x4033

The IDT logo is a registered trademark of Integrated Device Technology, Inc.



LittleDiode supplies new, hard to find or obsolete electronic components and semiconductors all over the world.

With over two million different components listed you are sure to find the part you need.

Feel free to visit us today at our online store:

LittleDiode.com

Looking forward to providing you with the best possible service.